



Apple Technician Guide



MacBook Pro (15-inch, Late 2008)

Updated: 2010-12-17

 Apple Inc.

© 2008 Apple Inc. All rights reserved.

Under the copyright laws, this document may not be copied, in whole or in part, without the written consent of Apple.

Every effort has been made to ensure that the information in this document is accurate. Apple is not responsible for printing or clerical errors.

Apple
1 Infinite Loop
Cupertino, CA 95014-2084
USA
+ 1 408 996 1010
www.apple.com

Apple, the Apple logo, Mac, MacBook, and Macintosh are trademarks of Apple Inc., registered in the U.S. and other countries.

Please send feedback to smfeedback2@apple.com.

MacBook Pro (15-inch, Late 2008)

Contents

Manual Updates 8

Updated 17 December 2010	8
Updated 15 June 2010	8
Updated 14 May 2010	8
Updated 08 February 2010	8
Updated 3 December 2009	8
Updated 16 November 2009	9
Updated 01 July 2009	9
Updated 17 June 2009	9
Updated 15 June 2009	9
Updated 1 June 2009	9
Updated 14 April 2009	9
Updated 18 March 2009	10
Updated 3 March 2009	10
Updated 17 December 2008	10
Updated 14 November 2008	11
Updated 21 October 2008	11
Manual introduced 14 October 2008	12

Basic

Overview 14

Identifying Features	14
Product Configurations	15

Serial Number Location 16

Serial Number On Top Case	16
Transferring the Serial Number	16

General Information 17

Required Tools	17
The Glass Panel	18
Keycap Replacement	19

Troubleshooting

General Troubleshooting 21

Update System Software	21
Apple Service Diagnostics	21

Test Points	21
Troubleshooting Theory	21
Hardware vs. Software	22
Clamshell Service Diagnostic Read Me	22
Apple Hardware Test	23
Functional Overview	24
Block Diagram, MacBook Pro (15-inch, Late 2008)	25
Liquid Submersion Indicators	26
Common Reset Procedures	26
Display Issue: Pixel Anomalies	28
Display Hinge Behavior	29

Symptom Charts 30

Startup and Power Issues	30
No Power	30
Won't Start Up	33
Intermittent Shutdown	36
No Video/Bad Video	41
Battery Isn't Recognized or Won't Charge	44
Kernel Panic/System Crashes	47
Battery Run Time Too Short	50
Won't Run on Power Adapter Alone	51
Power Adapter Issue	52
Noise / Hum / Vibration	53
Burnt Smell / Odor	55
Battery Leaking or Swollen	56
Uncategorized Symptom	56
Communications	57
Ethernet Port/Device Issue	57
AirPort/Bluetooth: Defective Wireless Devices	59
No/Poor Wireless Signal	61
Bluetooth Wireless Input Device Loses Connection	62
AirPort Card: Kernel Panic	64
Wireless Performance Issue / Slow Connection	66
Wireless Input Device Doesn't Pair	68
Uncategorized Symptom	70
Display	71
Display Anomalies	71
Defective Camera / Built-in iSight Not Operating Correctly	76
Backlight Issue / No Backlight	78
Noise / Unstable Flickering	79
Mechanical/Physical Damage	80
Cosmetic Defects	81
Uncategorized Symptom	81
Mass Storage	82
Hard Drive Read/Write Issue	82

Hard Drive Not Recognized/Not Mounting	83
Hard Drive Noisy	85
Optical Drive Won't Accept/Reject Media	86
Optical Drive Read/Write Data Error	88
Optical Drive Not Recognized/Mount	90
Optical Drive Noisy	91
Optical Drive Not Performing to Specs	93
Uncategorized Symptom	94
Input/Output Devices	95
USB Port Does Not Recognize Known Devices	95
Built-in Keyboard Does Not Work Properly	96
Specific Keys Don't Work	97
Built-in Trackpad Does Not Work	98
Built-in Keyboard Has Dim or No Keyboard Backlight	100
Built-in Keyboard Is Not Recognized	101
Built-in Trackpad Does Not Track Properly	102
Apple Remote Inoperable	103
Built-in Speaker Has No Audio	104
Distorted Sound from Internal Speaker	105
Express Card Will Not Insert Into Slot	107
Express Card Not Recognized By System	108
FireWire Port Not Recognizing Known Devices	109
Uncategorized Symptom	109
Mechanical Issues: Thermals and Enclosure	110
Reset/Power Button Stuck	110
System Runs Hot	111
Uncategorized Symptom	113

Take Apart

General Information 115

Connector Types on Logic Board	115
--------------------------------	-----

Access Door 118

Battery 120

Removal	121
Replacement	121

Hard Drive Bracket 123

Removal	124
Replacement	125

Hard Drive 126

Removal	127
Replacement	129

Reinstalling Software that Came with the Computer 131
Installing Applications 131

Bottom Case 132

Bottom Case Information 134

Memory 135

Removal 136

Replacement 137

Midwall 138

Removal 139

Replacement 140

Battery Connector Cover 141

Battery Indicator Light Board 143

Removal 144

Replacement 144

Battery Indicator Cable 145

Removal 146

Replacement 146

Camera/AirPort/BT Cable Guide 147

LVDS Cable Guide 149

Display Assembly 151

Replacement 155

Display Hinge Behavior 155

Display Clutch Cover 156

Removal 157

Replacement 158

AirPort Card 160

Removal 161

Replacement 162

Antenna Board 165

Removal 166

Replacement 166

Optical Drive 167

Replacement 170

Optical Drive Flex Cable 171

Right Speaker / Subwoofer 173

Hard Drive Connector Cable 175

Removal 176

Replacement 177

Fans 178

Logic Board 180

Heatsink 187

Removal 188

Replacement 189

Trackpad 191

Removal 192

Replacement 195

Battery Power Cable 200

Left Speaker 202

Microphone 205

MagSafe Board 207

Center Bracket 209

Cable Clip for AirPort Card 211

HD Front Bracket/Flex Cable with IR and Sleep LED 212

Express Card Cage 216

Kensington Lock 218

Top Case 220

Removal 221

Replacement 221

Top Case Information 222

Views

Exploded Views 224

Main Assembly 1 224

Main Assembly 2 225

Display Assembly 226

External Views 227

Front View 227

Port View 228

Screw Chart 229

Screw Location Diagrams 231

Bottom Case Screws 231

Top Case to Display Assembly Screws 232

Main Modules to Top Case Screws 233



Manual Updates

Updated 17 December 2010

Troubleshooting:

- Symptom Charts: Display: Backlight Issue/No Backlight: Replaced steps 5 and 6 of Deep Dive

Updated 15 June 2010

Troubleshooting:

- General Troubleshooting: Resetting the System Management Controller (SMC): Updated text to clarify MagSafe LED behavior; deleted text requiring resetting date and time.

Updated 14 May 2010

Basics:

- General Information: Keycap Replacement: Service packages of 78 replacement keycaps are now available in the U.S. and Canada (U.S. version keyboard only) for designated MacBook and MacBook Pro computers.

Troubleshooting:

- Troubleshooting: I/O Symptom Chart: Built-in Keyboard Does Not Work Properly: Deep Dive: Action: Step 1 updated.
- Troubleshooting: I/O Symptom Chart: Specific Keys Don't Work: Quick Check: Step 5 updated.

Updated 08 February 2010

Take Apart:

- Bottom Case: Added section with graphics called "Bottom Case Information" that discusses two catches that are no longer present on current production bottom cases
- Logic Board: Added information in step 11 about I/O bracket and screws that are no longer required with current production top cases
- Top Case: Added section with graphic called "Top Case Information" that discusses a bracket that is no longer present on current production top cases

Updated 3 December 2009

Troubleshooting:

- General Troubleshooting: Added new section "Clamshell Service Diagnostic Read Me"
- Symptom Charts: Startup and Power Issues: Revised for Clamshell Service Diagnostic (CSD) considerations
- Symptom Charts: Communications: Revised for CSD considerations
- Symptom Charts: Display: Revised for CSD considerations



Updated 16 November 2009

Basic:

- General Information: Required Tools: Changed Torx T6 screwdriver to require one with a large-diameter handle for a better grip on tight screws

Take Apart:

- Display Assembly: Added replacement note about installing foam gasket; revised “Tools” to specify a Torx T6 screwdriver with a large-diameter handle for a better grip on tight screws
- Logic Board: Added replacement note about installing foam gasket.

Updated 01 July 2009

Take Apart:

- Display Assembly, Optical Drive, and the Logic Board chapters were updated with information about the shim located behind the camera cable connector. If the shim is not replaced during reassembly, the camera cable could work loose, resulting in no video.
- A replacement shim is now included with replacement logic boards.

Updated 17 June 2009

Take Apart:

- Display Assembly chapter was updated with a topic on “Display Hinge Behavior.”

Troubleshooting:

- General Information chapter was updated with a topic on “Display Hinge Behavior.”

Updated 15 June 2009

Take Apart:

- Revised wording on Replacement step 3 in the AirPort Card chapter.

Updated 1 June 2009

Take Apart:

- Added [TrackPad](#) procedure.
- Logic Board: Removed reference to MagSafe screws in graphic, added note to alert techs not to remove MagSafe screws during logic board removal.

Views:

- Added TrackPad kit (922-9008) to exploded view diagram

Updated 14 April 2009

Troubleshooting:

- Display/Display Anomalies: Deep Dive: [Vertical/Horizontal Lines table](#) added with graphics showing symptom.

Take Apart:

- [Front Bracket/IR/Sleep Indicator cable](#): Updated procedure, with new text and cable



connector graphics

- Logic Board: Updated procedure with [IR/Sleep cable connector caution](#).

Updated 18 March 2009

Troubleshooting:

- General Troubleshooting: Added information on Apple Hardware Test. There are two versions of [Apple Hardware Test \(AHT\)](#) for the MacBook Pro (15-inch, Late 2008). To identify which version of AHT to use, check the third, fourth, and fifth digits in the system serial number
- Intermittent Shutdown: Added table "[Troubleshooting Shutdown Causes](#)"

Take Apart:

- MagSafe Board: Updated removal procedure and added graphic to port test using unplugged power adapter cable
- Logic Board: Updated cable disconnect procedure (step 8) and added new graphic in step 13
- Optical drive: Updated graphic showing a shim next to connector on AirPort/Bluetooth/camera cable
- Front Bracket/IR/Sleep Indicator cable: Updated removal procedure, to remove trackpad flex cable first, before disconnecting the IR/Sleep cable from the logic board.

Updated 3 March 2009

General Information:

- New "[Replacement Caution](#)" graphics added to Thin, Multi-Pin Horizontal Insert topic
- New topic added: [Display Issue: Pixel Anomalies](#)

Take Apart:

- Mag Safe: Replacement Note added. Check the port connection by plugging in a disconnected power adapter cable. If the MagSafe port is off center, the cable will not plug in securely, and you must reinstall the MagSafe board.
- Logic Board: New text and graphics added showing a [shim](#) and a new EMI gasket on the AirPort/Camera/Bluetooth cable.

Troubleshooting:

- Updated links in [Deep Dive: Pixel Anomalies table](#)

Views:

- Added part numbers to exploded views
- Added two new part numbers to Screw Chart, 922-8994 and 922-8995

Updated 17 December 2008

- General Information:
 - Corrected link to Knowledge Base article 50020
 - Added Apple Service Diagnostics and Apple Hardware Test diagnostic versions
 - Block Diagram: updated memory to DDR3 and Bluetooth to 2.1
- General Troubleshooting



- Added Apple Service Diagnostic heading and a sensor chart with name and location of sensors
- Removed reference to Knowledge Base article HT3221
- Updated text to use a tweezer to insert locking-lever flex cables
- Symptom Charts
 - Updated Intermittent Shutdown/Deep Dive/Step 6/Yes Action and Code changed from X03 to M08
 - Updated Display/Blank/No Video/added “Unlikely Cause”
 - Updated Display/Backlight Issue/No Backlight/added “Unlikely Cause”
 - Updated Display/Noise/ Unstable Flickering/added “Unlikely Cause”
 - Updated Display/Added new symptoms for Backlight Issue / No Backlight
 - Updated InPut/Output Devices/ Specific Keys Don’t Work /added “Unlikely Cause”
- Take Apart
 - Battery: added note to seat the battery connector
 - Bottom case: added 2 replacement steps
 - Memory: added additional removal information on step 2
 - Logic board: updated graphic in step 7; Removal: added screw sizes in step 8, reword camera cable to Camera/AirPort/Bluetooth cable
 - Heatsink: added black stick to step 1, added screw part number to step 2.
 - HD front bracket/IR/sleep LED: updated graphic in step 4
 - AirPort card: updated graphic in replacement step 1, noted using a black stick
 - AirPort Antenna board: added removal using a black stick; Replacement: added new graphic showing pink thermal pad on AirPort card.
 - Display assembly: added important note reminding technician to install a new thermal pad on the AirPort card whenever the display assembly is replaced and removed replacement note on step 8
 - Battery Indicator Cable: added screw part number on step 3
 - Camera Cable Guide: Step 2, renamed cable as Camera, AirPort and Bluetooth cable
 - Fans: updated screws, 4 identical (922-8754) and 2 longer (near the ODD, no 922-xxxx number offered yet).
- Exploded View
 - Added international AirPort Extreme/AirMac part numbers

Updated 14 November 2008

- Take Apart: Added important [replacement step in AirPort Card](#) chapter alerting technicians to check that the AirPort cable is inserted in the proper orientation into the AirPort Card connector. If the cable is inserted backwards it will damage the logic board.
- Troubleshooting: Updated [Burnt Smell/Odor symptom](#). Added step 3 in the Quick Check to check AirPort Card cable orientation.

Updated 21 October 2008

- Updated Features and Specs
- Take Apart: Reorganized topic sequence following Display Assembly chapter
- Added Caution notes to the Display Assembly and HD Front Bracket/IR/Sleep Cable chapters.
- Added important replacement note to Logic board section about plugging in audio cable when main logic board is not mounted into top case.



-
- Added Replacement Troubleshooting tip to HD Front Bracket/IR/Sleep Cable chapter to reseal the IR/Sleep Cable if the system is having trouble going to sleep or stays asleep.

Manual introduced 14 October 2008

Apple Technician Guide

Basic

MacBook Pro (15-inch, Late 2008)



Overview



The MacBook (15-inch, Late 2008) computer features both the NVIDIA GeForce 9400M integrated graphics processor and a high-performance NVIDIA 9600 GT graphics processor. Multi-Touch trackpad, and aluminum body. Refer to more features below.

Identifying Features

The main features and service differences include:

- Aluminum unibody enclosure, machined from a single piece of aluminum
- Ultrathin 15-inch LED-backlit glossy display, 1440 by 900 pixels
- Mini DisplayPort connector
- Express Card slot, 34mm
- Battery indicator button on left side
- Illustrations for removing the battery, hard drive, and memory cards are pictured on the inner side of the access door.
- Product identification label is on top case inside front edge, visible when the access door and battery are removed.



Product Configurations

The following table shows the MacBook (15-inch, Late 2008) model configurations at introduction:

Feature	Better (MB470)	Best (MB471)
Intel Core 2 Duo processor	2.4 GHz 3MB sharedL2 1066MHz frontside bus	2.53 GHz 6MB shared L2 2.8 GHz 6 MB L2 CTO 1066MHz frontside bus
Graphics	NVIDIA GeForce 9400M (MCP79) + NVIDIA GeForce 9600M GT 256MB VRAM	NVIDIA GeForce 9400M (MCP79) + NVIDIA GeForce 9600M GT 512MB VRAM
Memory, DDR3 1066, SO-DIMMs	2 GB (2 x 1 GB)	4 GB (2 x 2 GB)
Hard Drive, Serial ATA 100 5400 rpm	2.5" SATA, 250 GB, 5400 Option: up to 320GB at 7200 rpm or 128GB SSD	2.5", 320 GB SATA , 5400 Option: up to 320GB at 7200 rpm or 128GB SSD
Optical Drive (SATA)	8x DL Super, 9.5 mm	8x DL Super, 9.5 mm
Housing	Aluminum	Aluminum
Display	15.4-inch glass LCD, 1440 x 990 pixels, LED backlight, glossy finish	
I/O	USB: 2- USB 2.0 (1 high powered) FireWire: 1-FW800 Video I/O: Mini Display Port Audio I/O: Combo digital.analog in, Combo digital/analog/iPhone headset out, Microphone, Stereo speakers with subwoofer Camera: Wave 4 camera (f2.4, 3 micron pixel (640x480)) Other: IR, Battery Indicator Light, 34mm Express card	
Keyboard	Backlight	
Battery	Lithium-polymer battery, up to 5 hours	
Power Adapter	85W MagSafe Power Adapter	

Note About Images in This Manual

Because a pre-production or very similar model was used for most of the images shown in this manual, you may notice small differences in appearance between the image pictured and the computer you are servicing. However, although the appearance may differ, the steps and sequence are the same unless noted.



Serial Number Location

Serial Number On Top Case

Remove the access door and battery to see the serial number on the inside front wall of the top case.

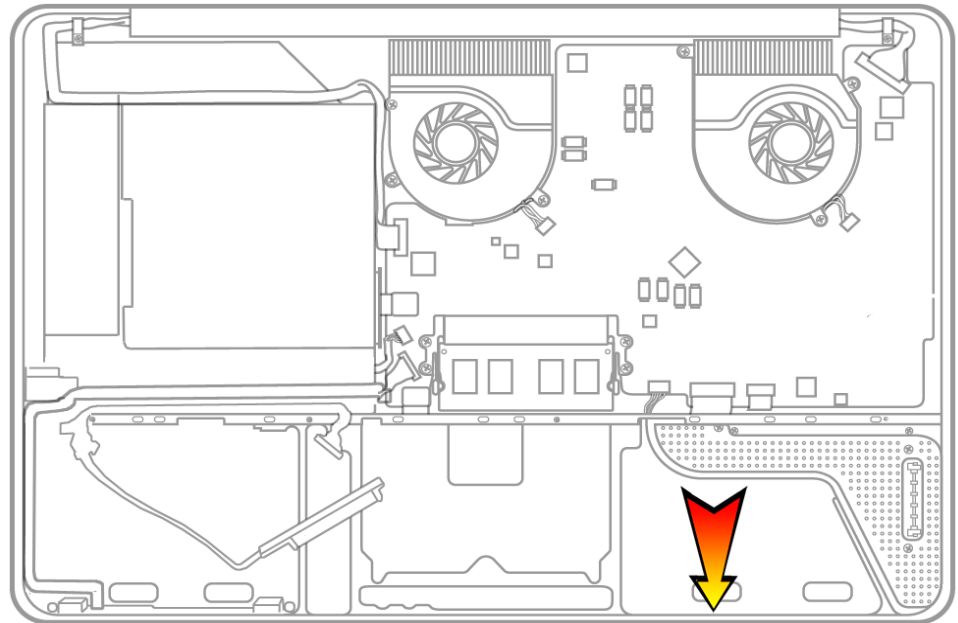

Transferring the Serial Number

Before installing the replacement top case, transfer the serial number to the replacement top case. Peel up the original serial number label with a jeweler's flat blade screw driver and transfer it to the inside edge of the replacement top case (see arrow for location).



General Information

Required Tools

Caution: To prevent scratches or other cosmetic damage to the computer housing, use a soft cloth as a protective layer when removing and installing the external screws.

The following tools are required to service the computer:

- Clean, soft, lint-free cloth
- ESD wrist strap and mat
- Magnetic Phillips #0 screwdriver
- Magnetic Phillips #00 screwdriver (preferably with a long handle)
- Torx T6 screwdriver with a large-diameter handle for a better grip on tight screws
- Tri-lobe #0 screwdriver (922-8991), for trackpad removal
- Black stick (Apple probe tool, part number 922-5065) or other nonconductive nylon or plastic flatblade tool
- Thermal grease (Apple thermal compound syringe, part number 922-7144)
- Alcohol wipes
- Foam wedge fixture for display assembly removal (part number 922-8779)
- Kapton tape
- Tweezers, ESD safe, extra fine points, for flat cable replacement

Refer to Knowledge Base article “Hand Tools for Desktop and Portable Repairs--AP/CA/EU/JP/LA/US” to purchase tools:

<http://docs.info.apple.com/article.html?artnum=500200>

In addition, the following software programs are required for troubleshooting:

- Apple Service Diagnostic (ASD), version 3S125
- Apple Hardware Test, version 3A148



The Glass Panel

Warning: The glass panel for this model is not a serviceable part. If the glass is broken or scratched, replace the display assembly. Attempting to remove the glass can permanently shatter the display face and damage other parts.

To clean the glass panel, use the Apple polishing cloth (922-8245) and iKlear Apple Polish or Brilliance anti-static spray cleaning solution. Alternatively, IPA (isopropyl alcohol) can be used.





Keycap Replacement

Service packages of 78 replacement keycaps are now available in the U.S. and Canada (U.S. version keyboard only) for designated MacBook and MacBook Pro computers. The packages allow you to replace individual keycaps rather than the entire top case.

There are four different keycap packages, based on the color of the key and the type of keyboard (version D and S).

Part number	Key color	Keyboard
922-9277	Black	Version D
922-9279	Black	Version S
922-9278	White	Version D
922-9280	White	Version S

For step-by-step instructions, refer to the relevant support article: [“MacBook/MacBook Pro: Black Keycap Replacement” \(HT4002\)](#) or [“MacBook: White Keycap Replacement” \(HT4003\)](#).

For an overview of the differences among keycap procedures, refer to [“MacBook/MacBook Pro: Keycap Replacement Matrix” \(HT4001\)](#).

Apple Technician Guide

Troubleshooting

MacBook Pro (15-inch, Late 2008)



General Troubleshooting

Update System Software



Important: Whenever possible before beginning troubleshooting, ensure the latest software and firmware updates have been applied.

Apple Service Diagnostics

Run Apple Service Diagnostic to determine if any of the thermal sensors are malfunctioning. Replace any failing sensors. See chart below for correlation between error code and part.

Name	Location
TC0D	Logic Board
TC0P	Logic Board
TG0D	Logic Board
TG0H	Logic Board
TG0P	Logic Board
TG0T	Logic Board
TG1H	Heatsink
Th2H	Logic Board
TN0D	Logic Board
TN0P	Logic Board
Tm0P	Logic Board
Ts0P	Trackpad flex
TB0T	Battery pack
TB1T	Battery pack
TB2T	Battery pack
TB3T	Battery pack

Test Points

There is no silkscreen text on final production logic boards. Test points mentioned in troubleshooting charts are solely for reference.

Troubleshooting Theory

For general information on troubleshooting theory, refer to:

http://service.info.apple.com/service_training/en/006/troubleshoot/index.php?page=intro



Hardware vs. Software

For information on how to isolate a hardware issue from a software issue, refer to:

http://support.apple.com/kb/TS1388?viewlocale=en_US

TS1394—Mac OS X: Troubleshooting installation and software updates <<http://support.apple.com/kb/TS1394>>

HT2956—Troubleshooting Mac OS X installation from CD or DVD <<http://support.apple.com/kb/HT2956>>

For information on how to troubleshoot a software issue, refer to:

HT1199—Mac OS X: How to troubleshoot a software issue <<http://support.apple.com/kb/HT1199>>

Clamshell Service Diagnostic Read Me

Isolating video and wireless issues in portable computers can be time consuming and confusing. The Clamshell Service Diagnostic (CSD) is a new diagnostic tool that checks Apple's latest portable computers for the presence of AirPort, Bluetooth, LCD and Ambient Light Sensor (ALS) to assist you in quickly making a failure determination.

Troubleshooting benefits of using CSD include:

- Quick way (less than 1 minute) to determine whether clamshell-related modules (AirPort, Bluetooth, LCD and ALS) are electrically connected without taking apart the system.
- Results of CSD can help pinpoint if any clamshell cables may need to be reseated to logic board.
- Diagnostic results can help isolate a video or wireless issue to either the clamshell or the logic board, to avoid unnecessary replacements of these components.

CSD checks for the presence of the computer's:

- AirPort
- Bluetooth
- LCD
- ALS

CSD does not check for the presence of the computer's:

- iSight camera
- externally connected hardware components (such as USB or FireWire devices)

CSD does not check for issues with the OS X or other software-related problems such as application or extension conflicts.



Apple Hardware Test

There are two versions of Apple Hardware Test (AHT) for the MacBook Pro (15-inch, Late 2008). To identify which version of AHT to use, check the third, fourth, and fifth digits in the system serial number. See examples below.

- Apple Hardware Test 3A147 to be used on systems with the third, fourth, and fifth serial number digits below 911. Example: Serial number W 8 **8 4 0** H Q R I G 0
- Apple Hardware Test 3A163 to be used on systems with the third, fourth, and fifth serial number digits equal to or higher than 911. Example: Serial number W 8 **9 1 1** 7 0 R I G A



Functional Overview

Refer to this diagram for symptoms related to MacBook Pro (15-inch, Late 2008) logic board connectors.

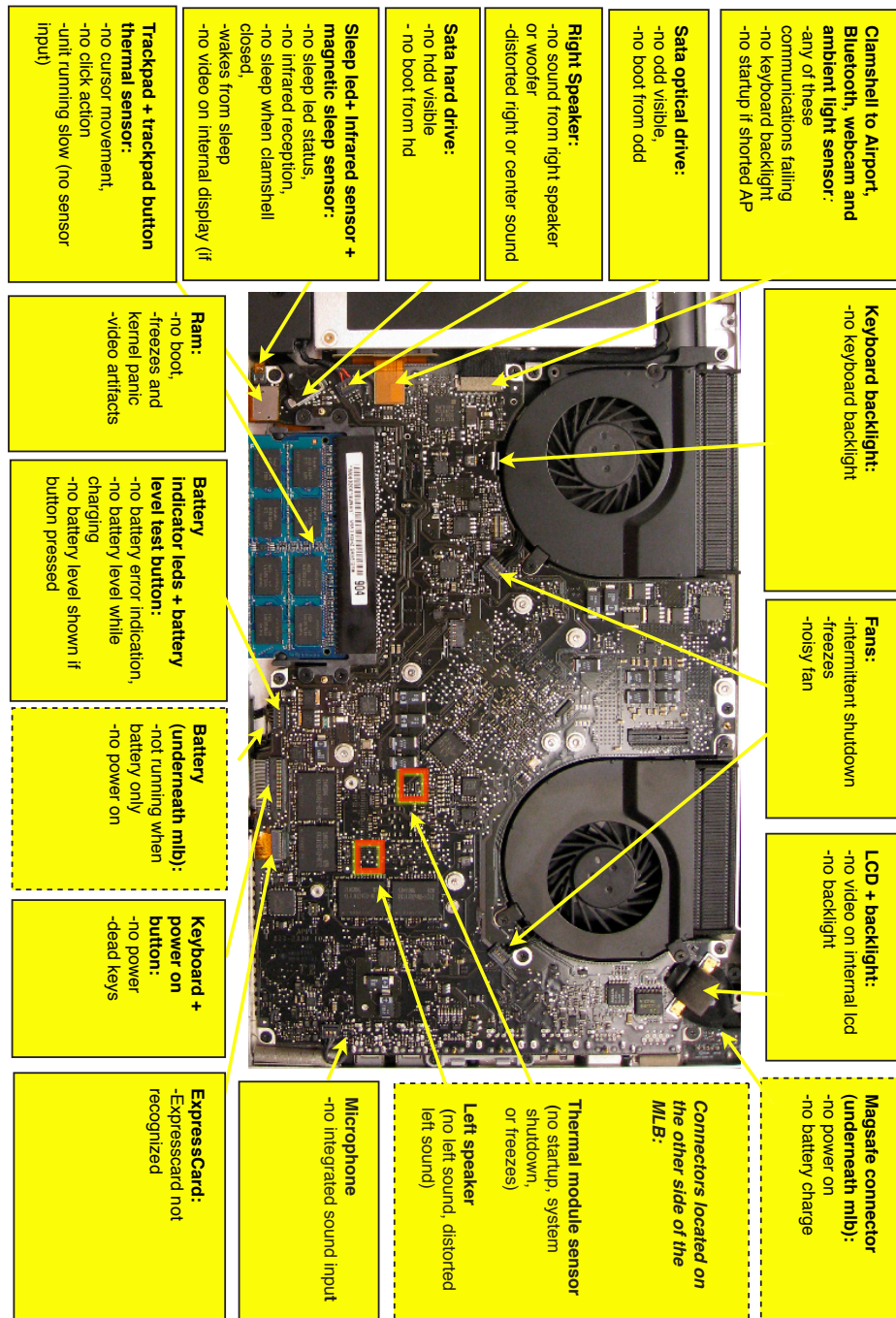



Block Diagram, MacBook Pro (15-inch, Late 2008)

Refer to this diagram to see how modules are interrelated.

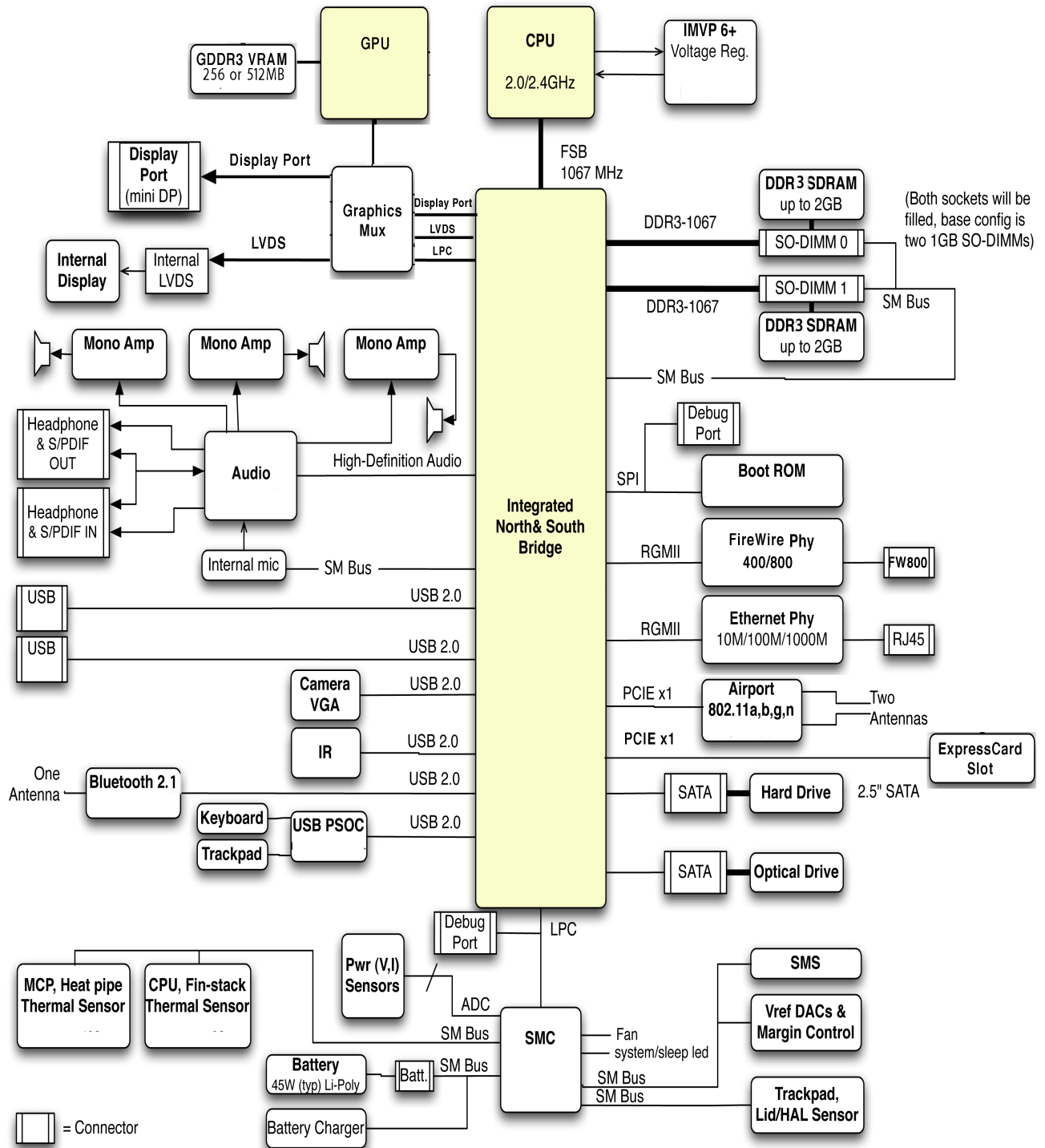



Liquid Submersion Indicators

Liquid submersion indicators (LSI) have been added to specific locations on current Mac portables to help determine if systems have been damaged by liquid. The sensors are only visible when the bottom case and some of the modules have been removed. Normally represented by small white dots, the LSIs turn red when they have come in contact with liquid, such as an accidental spill.

For more information, refer to Knowledge Base article HT3400: “About Liquid submersion indicators (LSI) on portable computers.” <http://support.apple.com/kb/HT3400>

Common Reset Procedures

When a reset procedure is required for troubleshooting, follow the applicable steps:

Resetting the System Management Controller (SMC)

To reset power management via the SMC chip:

1. If the computer is on, turn it off.
2. Disconnect the power adapter and remove the main battery.
3. Hold the power button down for five seconds, then release.
4. Install the main battery and connect the power adapter.
5. Press the power button to restart the computer.

Resetting the SMC means you will also need to reset the date and time (using the Date & Time pane of System Preferences).

For more information:

<http://www.apple.com/support>

HT1411 — Apple Portables: Resetting the System Management Controller (SMC) <<http://support.apple.com/kb/HT1411>>

Resetting the Parameter RAM (PRAM)

To reset PRAM,

1. If the computer is on, turn it off.
2. Locate the following keys on the keyboard: Command, Option, P, and R. You will need to hold these keys down simultaneously in Step 4.

Note: If the keyboard does not have an Option key, use the Alt key instead.

3. Turn on the computer.
4. Press and hold the Command-Option-P-R keys.



Important: You must press this key combination before the gray screen appears.

5. Hold the keys down until the computer restarts and you hear the startup sound for the second time.
6. Release the keys.

For more information:

<http://www.apple.com/support>

HT1379—Apple Portables: Resetting the PRAM <<http://support.apple.com/kb/HT1379>>

Starting Up in Safe Mode

A Safe Boot is a special way to start Mac OS X when troubleshooting. To start up into Safe Mode (Safe Boot),

1. Make sure the computer is shut down.
2. Press the power button.
3. Immediately after you hear the startup tone, press and hold the Shift key.
Note: The Shift key should be held as soon as possible after the startup tone but not before.
4. Release the Shift key when you see the screen with the gray Apple and progress indicator (looks like a spinning gear). During startup, “Safe Boot” appears on the Mac OS X startup screen. To leave Safe Mode, restart the computer normally, without holding down any keys during startup.

For more information:

<http://www.apple.com/support>

HT1564—What is Safe Boot, Safe Mode? <<http://support.apple.com/kb/HT1564>>

TS1884—Safe Boot take longer than normal startup <<http://support.apple.com/kb/TS1884>>



Display Issue: Pixel Anomalies

When displaying a single color over the screen area, the LCD panel might show one or more pixels that are not properly lit. To determine if the display has an acceptable number of pixel anomalies, follow the steps below:

1. Set the display image to one of the following colors: all-white, all-red, all-green, all-blue, or all-black display. Knowledge Base article 112125: "Service Diagnostics Matrix," has the LCD Tester Diagnostic Utility that will generate these patterns on the screen.
2. Using a jeweler's loupe, pocket microscope, or other magnifying device, identify and count each pixel anomaly:

Bright subpixel anomaly = subpixel that is always on

Dark subpixel anomaly = subpixel that is always off

3. The number of acceptable pixel anomalies for this computer is:

Bright	Up to 3
Dark	Up to 5
Combination	Up to 7

4. If the number of subpixel anomalies exceeds the acceptable number shown above, replace the LCD panel display assembly. Numbers outside the acceptable range would be

Bright	4 or more
Dark	6 or more
Combination	8 or more

5. If the number of subpixel anomalies is acceptable, explain to the customer that the pixel anomalies are within specifications, and no repair is necessary.

Important: Do not release the specifications to customers. Instead, inform them that a certain number of subpixel anomalies are considered acceptable, and these factors apply to all manufacturers using LCD technology—not just Apple products.

When speaking with customers, please use the following explanation:

- Active-matrix LCD technology uses rows and columns of addressable locations (pixels) that render text and images on screen. Each pixel location has three separate subpixels (red, green, and blue) that allow the image to be rendered in full color. Each subpixel has a corresponding transistor responsible for turning the subpixel on or off.
- There are typically millions of these subpixels on an LCD display. For example, the LCD panel used in the Apple Cinema HD display is made up of 2.3 million pixels and 6.9 million red, green, and blue subpixels. Occasionally, a transistor does not work perfectly, which may result in the affected subpixel being turned on (bright) or turned off (dark). With the millions of subpixels on a display, it is quite possible to have a low number of faulty transistors on an LCD. Therefore, a certain number of subpixel anomalies are considered acceptable. Rejecting all but perfect LCD panels would significantly increase the retail price for products using LCD displays. These factors apply to all manufacturers using LCD technology—not just Apple products.



Display Hinge Behavior

The MacBook Pro models have a unique counterbalanced clutch system. The design provides a smooth, fluid feel when opening, closing, or positioning the display. The counterbalanced clutch system was designed so that when the display is vertical with respect to the ground, it will remain in place regardless of the angle of the base.

Moving the display past vertical allows the hinges to release and the display to close. This is normal behavior and no repair is necessary. Refer to <http://support.apple.com/kb/HT3304> for more information and to watch a video of this hinge behavior.





Symptom Charts

Follow the steps in the order indicated below. If an action resolves the issue, retest the system to verify. **Note:** A compilation of Quick Check tables is available at <http://service.info.apple.com/QRS/en/quickreference.pdf>.

Note: There is no silkscreen text on final production logic boards. The photos shown with test points are from pre-production units and are solely for reference.

Startup and Power Issues

No Power

Unlikely cause: display assembly, speakers, optical drive, hard drive

Quick Check

Symptom	Quick Check
No Power / Dead Unit <ul style="list-style-type: none">• No power• No image• No startup chime• No fan or hard drive spin• No reset sound from optical drive• No sleep LED activity• No light if Caps Lock pressed• Non-operational	<ol style="list-style-type: none">1. Verify AC power presence with MagSafe LED indicating on or charge state.2. Verify battery status as being partly charged, charging with AC power.3. Reset SMC.4. Refer to Deep Dive table for battery diagnostic testing.



Deep Dive

Check	Result	Action	Code
1. Isolate peripherals as cause. Disconnect all peripherals and external devices and verify unit starts.	Yes	Suspect peripherals as cause. Reconnect each one at a time, verifying unit operation as external device is reinstalled.	
	No	Go to step 2	
2. Reset SMC, and verify unit starts. (Alternative hardware SMC reset can be forced by shorting R5001 pads on logic board or removing all system power for 1 minute.) Can system start up after SMC reset?	Yes	Corrupt SMC state preventing power on. Issue resolved with SMC reset.	
	No	Go to step 3	
3. Will system power up with battery only? Check battery level LED indicator for status of battery charge or battery use error. Inspect battery connector for burn marks or damaged pins if substituting a known-good battery to verify starting on battery.	Yes	System can start up from known-good battery -- customer battery possibly at fault or needs to be charged. Continue to verify customer battery then AC adapter use and battery charging. Go to step 4.	P11
	No	System will not power using known-good battery only. Go to step 5	
4. Customer battery may be run down, or not recognized. Verify customer battery in a known-good system is recognized and accepting a charge. Confirm customer battery is not consumed nor defective.	Yes	Battery is recognized, charging and health is good. Return to test unit with customer battery and AC adapter power. Go to step 6.	
	No	Replace customer battery for not charging (P10) or not recognized (P11). Customer to purchase a replacement battery if consumed.	P10 or P11



5. Inspect battery cable connection at logic board and reseal if necessary. Replace cable if found damage or burned. Can the system power on from a charged battery with battery cable inspections or replacement?	Yes	Battery power restored, return to test unit with customer battery and AC adapter power. Go to step 6.	
	No	Logic board is expected to power on with battery only. Inspect and test power on key. Go to step 10.	
6. Inspect MagSafe power adapter. Verify AC adapter is correct wattage, compatible with product and works on known-good computer.	Yes	Power adapter is good, go to step 7	
	No	Release stuck pin or replace adapter due to wire damage, not working or burned pins	P14
7. Inspect MagSafe port on computer for physical damage, debris or metal fragments attracted to magnetic connector. Is MagSafe connector clean and free from defects?	Yes	Go to step 8	
	No	Clean port assembly. Replace MagSafe board if necessary.	X03
8. Verify adapter status LED turns on green then orange indicating power and battery charge in progress. A green LED can indicate a full battery, removal of battery or battery not recognized.	Yes	System starts and has power. MagSafe LED indicates power is flowing to logic board. Verify customer battery will also charge. Review battery health to ensure customer satisfaction.	P11
	No	AC power is down or battery is not charging. Go to step 9	
9. Verify power from adapter is present on logic board. Remove system battery, use AC power only. Reseat or test known-good MagSafe cable to achieve power for logic board.	Yes	Logic board has power adapter energy to start system. MagSafe cable reseal or replacement resolved issue. If still no system power on indications, go to step 10	X03
	No	AC adapter power not going to logic board power supplies. Replace logic board.	M21

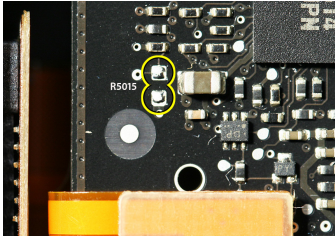

<p>10. Test and inspect Top Case Power Button. Stuck or open power on key or keyboard disconnect can disable the power on of system. If button does not work, locate pads R5015 on logic board just to right of IR/sleep cable. Short pads to power up logic board. If power on key is stuck, keyboard cable must be disconnected for R5015 to work. Does system power on? (Reconnect keyboard cable to confirm bad or intermittent connections.)</p>	Yes	Power on key works fine, issue resolved.	
		Power on key works when keyboard cable is reseated.	
		Power on key appears to be stuck, had to remove keyboard cable to power on. Replace top case for stuck power on key	K05
	No	No logic board power on when shorting R5015 pads. Replace logic board.	M01

Won't Start Up

Unlikely cause: display assembly, speakers, fan, camera, microphone

Quick Check

Symptom	Quick Check
<p>Power but No start up</p> <ul style="list-style-type: none"> No startup chime, some video activity, Apple logo, startup spin dial Startup chime with possible beep tones. Fan, hard drive spin or optical drive reset sound Sleep LED is on , blinking or went out Caps Lock LED toggles when pressed 	<ol style="list-style-type: none"> Reset SMC. Verify startup process passes initial memory checks – no beep errors or flashing sleep LED indicators. Display activity is starting up. Clear PRAM. Verify starts up from user drive. Connect known-good external bootable device and press Alt key during startup then select external startup device to bring up system for diagnostics. Verify presence and status of user hard drive. Use Disk Utility to repair drive and file permissions.



Deep Dive

Check	Result	Action	Code
1. Reset SMC and Clear PRAM to set default startup device to internal hard disk drive (HDD).	Yes	User hard drive bootable, issue resolved default settings.	
	No	Customer system not starting up, go to step 2	
2. Is system indicating a memory error with repeated sleep LED 1 or 3 flash sequence and beep tones if sound is enabled?	Yes	Troubleshoot memory issues, go to step 3	
	No	Continue with startup sequence verification go to step 4	
3. Reseat customer memory and/or swap in known-good memory to isolate bad memory and replace defective parts.	Yes	Customer memory defective and replaced. Continue to verify startup process. Go to step 4	X02
	No	Should known-good memory fail in one or more slots, replace logic board.	M07
4. Hold the Alt (Option) key during startup and verify there is a bootable hard drive shown in Startup Manager. Choose customer hard drive. Does start up from this drive work?	Yes	System starting up from customer hard drive. Startup issue resolved	
	No	Customer hard drive not present or does not start up from this drive. Continue to find bootable device. Go to step 5	
5. Insert product OS install disc in optical drive. Install disc is bootable and should be present in Startup Manager. Can system start up from OS install disc?	Yes	Starts up from optical drive - customer hard drive not yet bootable, go to step 8	
	No	Computer has no internal bootable devices. Test external startup devices, go to step 6	
6. Boot from a known-good bootable copy of product OS on a USB drive or network server to start up and verify internal mass storage devices are available using System Profiler and Disk Utility.	Yes	System started up from external device and reports data regarding internal SATA devices. Go to step 7	
	No	No startup devices available. Replace logic board	M02



7. Troubleshoot optical drive and optical drive cable with cable reseal and known-good part substitutions. Is there a defective optical drive component to replace?	Yes	Cable reseal solved issue. Continue to verify hard drive issues, go to step 8	
		Defective optical drive cable found and replaced. Continue to verify hard drive issues, go to step 8.	X03
		Defective optical drive found and replaced. Continue to verify hard drive issues, go to step 8	J03
	No	Replace logic board	M19
8. Use Disk Utility loaded from OS install disc to verify if hard drive is available on device list. Is customer hard drive listed in Disk Utility?	Yes	Customer hard drive available for inspections and repair. Go to step 10.	
	No	Hard drive not present, troubleshoot hard drive and cable. Go to step 9.	
9. Troubleshoot hard drive and hard drive SATA cable with cable reseal and known-good part substitutions. If customer hard drive, is there a defective hard drive component to replace?	Yes	Reseat of SATA cable now has customer hard drive visible in Disk Utility, go to step 10	
		Defective hard drive SATA cable found and replaced, now has customer hard drive visible in Disk Utility, go to step 10	X03
		Suspect customer hard drive defective, attempt OS restore, go to step 10	
	No	Known-good hard drive and known-good hard drive SATA cable used, still no hard drive present. Replace logic board	M19
10. Boot system with Shift key down. Does it work?	Yes	Go to software troubleshooting article	
	No	Go to step 11	



11. Use Disk Utility to repair customer hard drive and repair permissions if system OS found on hard drive. Is hard drive bootable after software repairs?	Yes	OS on customer hard drive repaired, issue resolved.	
	No	Hard drive not bootable, perhaps missing OS, go to step 12	
12. Use Disk Utility to partition customer hard drive with one GUID partition then restore Mac OS from product OS install disc. Is hard drive bootable after OS install?	Yes	Customer hard drive now starts up from new OS image, issue resolved	
	No	Replace hard drive.	H02

Intermittent Shutdown

Unlikely cause: hard drive, optical drive

Troubleshooting Shutdown Causes

Your computer's system log may record why it shut down or went into sleep mode. Reviewing SMC codes in the system.log of the Console application may provide some information about why the event occurred.

To review SMC codes in the system.log in Console:

1. Open the Console application. Console is located in the /Applications/Utilities/ folder.
2. Select Open System Log under the File menu.
3. Using the filter in the upper right corner, search for "Cause."
4. Use the table below to interpret the cause and review the suggestion if shutdown was unexpected.

Example: Entry found "Jun 6 18:06:28 localhost kernel[0]: Previous Shutdown Cause: 5"

By looking for the code 5 in table below, you will discover that computer shutdown was caused by user selection of System Menu option "Shutdown..."

Depending on the cause reported, the shutdown could be fixed by using the Quick Check or Deep Dive troubleshooting table.



Shutdown Cause Number	Cause	Suggested Fix
3	Forced shutdown: Normal behavior, if power button was pressed for more than 4 seconds.	If shutdown was unexpected, check top case (for power button stuck, or shorted cable).
5	Normal shutdown: Normal behavior if software initiated shutdown/restart.	If shutdown was unexpected, check Energy Saver setting in System Preferences.
-2	Power supply disconnected: Normal behavior if power source was removed from computer with no battery.	If shutdown was unexpected, check power cord/power supply (for intermittent failure or bad connection).
-60	Battery fully drained: Normal behavior if unit was left asleep on battery for too long.	If shutdown was unexpected, check/charge battery.
0	Battery/Power disconnected: Normal behavior if battery was removed while system was on and no other power source connected.	If shutdown was unexpected, check battery/power supply.
-62	Watchdog timer detected unresponsive application, restarting the system.	Troubleshoot for stuck application, startup item and any loading preferences.
-3	Temperature may be going over temp.	Run Apple Service diagnostics to check which sensor went beyond expected thermal limits.
-74	Battery temperature exceeds limits.	Swap battery and check with known good one to confirm issue is with battery over temp.
-75	Communication issue with AC adapter.	Check MagSafe connector/adapter plug/cable.
-95	Temperature may be going over temp.	If heatsink has thermal cable attached, check thermal heatsink connector. Otherwise check fan connection/activity..
-100	Power supply over temp.	Check sensors and fan.
-101	LCD may be going over temp.	Check LCD panel and fan.
-103	Battery cell under voltage detected.	Check the battery.

Quick Check

Symptom	Quick Check
---------	-------------



Intermittent shutdown <ul style="list-style-type: none"> • Powers off during startup • Powers off with desktop use 	<ol style="list-style-type: none"> 1. Verify battery charge status 2. Check AC adapter MagSafe connector and connection with system 3. Reset SMC and PRAM 4. Start up with shift key down for safe mode 5. Startup from known-good bootable device 6. Check system.log info for shutdown cause 7. Run AHT /ASD for sensors + thermal test
---	--

Deep Dive

Check	Result	Action	Code
1. Identify shutdown code recorded in system log file. Open the system.log file with console application. Search for occurrences of “previous shutdown cause” return codes. Verify system log looking for codes that indicate abnormal shutdown events.	Yes	-Intermittent power means checking battery health , AC source and MagSafe cable seating ;go to step 4 -Sleep means running sleep sensor test;go to step 7 -Overtemp means checking for clogged heatsink, shorted sensors cables or defective fan; go to step 8	
	No	system.log lists only normal shutdown codes, no codes related to heat sensors or power concerns. Go to step 2	
2. Reset SMC and clear PRAM; then monitor system performance to verify if system shutdowns cease. Are shutdown symptoms and events gone?	Yes	Shutdown cause related to SMC or PRAM resolved by changing to default settings.	
	No	Shutdown event still occurs. Go to step 3.	



<p>3. Start up from product OS install disc or from an external hard drive with product Mac OS. Are shutdown symptoms and events gone while starting up from this known-good Mac OS?</p>	Yes	Shutdown events cease on known-good OS. Reinstall Mac OS on customer hard drive and update OS with latest version and check if bootROM updates are available.	
	No	Symptoms unchanged - go to step 4	
<p>4. Check system running on battery only. Use known-good charged battery. Verify that shutdown/reset/sleep issues disappear when known-good battery is used without AC adapter.</p>	Yes	Recharge customer battery and retest. Check for customer battery health in Apple System Profiler or run battery testing utility, and replace if reported battery health is reported bad or consumed.	P09
	No	Symptoms unchanged - Go to step 5	
<p>5. Check with known-good AC adapter source only Remove battery and use known-good AC adapter. Does the shutdown/reset/sleep issue disappear with known-good adapter?</p>	Yes	Faulty adapter. Replace customer AC adapter if AC cable and duckhead were confirmed faulty.	P14
	No	Symptoms unchanged - Go to step 6	
<p>6. Check if power removed error reported "improper shutdown detected" in system.log If shutdown error is related to power removed shutdown cause, run ASD and check for overvoltage sensor failure reported.</p>	Yes	If voltage or current sensor failure confirmed in ASD with known-good DC and batteries, replace logic board.	MO8
	No	Go to step 9	



<p>7. Check if sleep event happens repeatedly in system.log If sleep/wake events are repeatedly reported, plug external monitor and run ASD to check for sleep sensor test. Verify if sleep sensor test is failing.</p>	Yes	Check for intermittently shorted sleep sensor in top case. If damaged, replace sensor/cable of top case.	X03
		Check IR cable is properly seated	X03
		Reseat and retest sleep sensor with ASD. If failing again, check for presence of magnet in display assembly above sensor.	X03
		If magnet present, replace sensor/cable or top case and retest. If still sleep sensing failing, replace logic board	M22
	if magnet missing replace display assembly	L15	
	No	Go to step 8	
<p>8. Check if over temp cause reported in system.log If shutdown error is related to over temp shutdown cause, run ASD and verify that a sensor or fan failure is reported.</p>	Yes	-If fan not running failure, check for fan cable seating and retest. If same failure after retest replace fan with known-good fan and retest. If does not happen with known-good fan, replace fan.	M18
		-If over temp failure reported check for cause of over temp like obstructed vent, dust in heatsink fin, or clogged fan and retest. If still failing replace part where sensor is located (logic board, battery, display assembly or trackpad) according to the sensor location table of service manual. Go to step 9	X03
	No	Replace Thermal module Go to step 9	X10



9. Isolate if issue solved Verify that shutdown/issue does not happen anymore after part exchange.	Yes	Issue fixed	
	No	Replace logic board with corresponding symptom: -if for thermal error cause -if for other cause	M18 M08

No Video/Bad Video

Unlikely cause: hard drive, optical drive, top case, battery, power adapter

Quick Check

Symptom	Quick Check
Power, but No Video <ul style="list-style-type: none"> • Power • No video • fan, hard drive spin, or optical drive reset sound • sleep LED is on or went on • light if Caps Lock pressed 	<ol style="list-style-type: none"> 1. Reset SMC. 2. Reset PRAM. 3. If no startup chime, verify with known-good memory. 4. Verify with external monitor. 5. Press Alt key on startup..

Deep Dive

Check	Result	Action	Code
1. Characterize video issue Define whether the issue is a bad image with backlight OR no video issue. Verify whether some image even distorted is visible.	Yes	Bad image quality, go to step 5	
	No	No image seen or no backlight, go to Step 2	
2. Isolate Peripherals as cause Disconnect all peripherals, external devices, Express Card and display adapters if present and verify that video is displayed.	Yes	Suspect peripherals as cause. Reconnect one at a time, verifying unit operation at each stage	
	No	Go to Step 3	



3. Adjust Brightness Power-on unit , attempt to adjust brightness to maximum using brightness (F1/F2) keys and verify that video is displayed.	Yes	Video displayed - Brightness set to minimum, panel backlight was inadvertently turned off. If backlight returns to low check for stuck F1 key on keyboard.	
	No	Go to Step 4	
4. Reset SMC Reset SMC and verify that system video is displayed.	Yes	Corrupt SMC State preventing video.	
	No	Go to Step 5	
5. Reset PRAM. If no action, use external keyboard with same sequence. Verify that system video is displayed.	Yes	Invalid or Corrupt PRAM contents affecting video output	
	No	Go to step 6	
6. Connect External video Connect known-good VGA/ DVI adapter to known-good display, press power button and close display to force main screen startup on external video. Verify that video is correct when displayed from external display.	Yes	Video correct on external display. Research available firmware and software updates, retest. If returning with software already updated, go to Step 7	
	No	Replace logic board with according symptom code: -no video -bad/distorted video	M03 M04



7. Isolate LCD display detection Disconnect external monitor and reopen display and restart unit. Verify that sleep LED indicator goes off after internal LCD has been detected.	Yes	Sleep LED goes off when LCD detected. -If still no video then Go to step 8, -If video present, but with defect, go to step 9	
	No	Internal LCD not detected. Run Clamshell Service Diagnostic utility and check for LCD panel presence. If not found, reseal LVDS cable connection on logic board and retest. If sleep led does not go off after cable is reseated, go to step 10	
8. Check for sleep sensor condition If display assembly sleep sensor is stuck in a closed state, video will appear on internal display temporarily, until the OS sleeps the system. Disconnect IR/sleep cable and restart unit without external display. Verify that system starts up with video on internal display stays on and does not go into sleep mode.	Yes	Sleep sensor was stuck or had shorted cable. Replace IR/sleep cable (or enclosing top case)	X13
	No	Symptoms unchanged - Go to Step 9	
9. Check for No Backlight Condition. Power on unit. Using a lamp or bright light source, inspect for faint image, and verify that any faint image appears.	Yes	Logo image visible - check and reseal LVDS cable connector on logic board. Inspect cables for damage near clutches: . if damaged, replace display assembly and go to step 11 . if cable is not damaged, run Clamshell Service Diagnostic utility and check for LCD panel presence. If not found, reseal it and retest, then go to step 11	L09
	No	If symptom continues, go to step 10.	



10. Verify with Known good display assembly Connect known-good display assembly to system.	Yes	System is functioning with known-good display assembly Replace display assembly if following symptom reporting: - had no power issue - had incorrect/missing colors - had blank video - had distorted / blurred video - had vertical/horizontal lines - had noise/unstable flickering - had dim backlight - had bad spot(s)/pixels - had no backlight - could not change resolution	L01 L02 L03 L04 L05 L06 L07 L08 L09 L10
	No	Symptoms unchanged - replace logic board	M03
11. Verify with reseated backlight cable or replaced display assembly Verify that unit now has video and backlight.	Yes	Issue was only due to damaged display assembly or unseated cable.	
	No	Display cable damaged the logic board. Replace logic board.	M25

Battery Isn't Recognized or Won't Charge

Unlikely cause: display assembly, speakers, optical drive, hard drive, trackpad

Quick Check

Symptom	Quick Check
Battery isn't recognized or won't charge <ul style="list-style-type: none"> • AC adapter • No MagSafe LED indicator • No orange charge indication • Battery status LEDs: <ul style="list-style-type: none"> - single chase - all flash - no LED 	<ol style="list-style-type: none"> 1. Check battery level and test AC power. 2. Refer to Deep Dive table for battery diagnostic testing.



Deep Dive

Check	Result	Action	Code
1. Does the MagSafe LED go green to amber when connected to the system?	Yes	Battery is recognized and charging. Go to step 6	
	No	LED is green, Battery may be full or not recognized. Go to step 2	
		LED was on momentarily then went out. Go to No Power for system (M01)	
2. When the Battery status button is pressed, did any of the lights come on?	Yes	Go to step 3	
	No	Go to step 11	
3. Does battery status indicate a fully charge battery with all LEDs on?	Yes	Customer battery charged, check health. Go to step 13.	
	No	Go to step 4	
4. Does battery status indicate the battery is not recognized with a single LED on that chases back and forth 5 times?	Yes	Go to step 8 and tag battery as a possible P11 candidate.	(P11)
	No	Go to step 5	
5. Does battery status indicate the battery is recognized but not charging with all LEDs blinking?	Yes	Go to step 8 and tag battery as a possible P10 candidate	(P10)
	No	Go to step 6	
6. Does battery status indicate battery charge and flash the next level 5 times?	Yes	Customer battery charging, check battery condition. Go to step 13	
	No	Flashing first LED only, go to step 7	
		No battery status LEDs on, go to step 11	
7. Does battery status indicate a low battery with a LED flashing rapidly indicating initial charging of battery?	Yes	Allow customer battery to charge to 1 LED on before checking battery condition. Go to step 13.	
	No	Go to step 8	



8. Test with a known-good battery. Is battery recognized and charging?	Yes	Replace customer battery (P10 not charging or P11 not recognized)	P10 or P11
	No	Go to step 9	
9. Inspect customer battery cable connector for corrosion or obstructions.	Yes	Clear obstructions and replace battery if corroded and recheck. (P10 not charging or P11 not recognized)	P10 or P11
	No	Go to step 10	
10. Reseat battery harness at logic board connector, and retest. Is battery recognized and charging?	Yes	Issue resolved by cable reseat. Check battery condition, go to step 13	
	No	Replace logic board	M20
11. Battery status LEDs not working - inspect button stuck or cable disconnect at logic board and reset SMC.	Yes	LED status now working. Go to step 3.	
	No	Go to step 12.	
12. Remove system battery and connect and test a known-good battery status indicator assembly. Do LEDs indicate a battery not recognized chase pattern?	Yes	Replace customer battery LED indicator assembly. Go to step 3	X03
	No	Replace customer logic board.	M20
13. Open Apple System Profiler and click on the Power Tab on the left. Is the battery over 300 cycle counts?	Yes	Battery has been consumed, and customer will need to purchase a replacement.	
	No	Go to step 14.	
14. Is battery less than a year old?	Yes	Go to step 16	
	No	Battery warranty expired, go to step 15	



15. Considering the age of the battery greater than one year old, is the health of the battery "Good" according to system profiler?	Yes	Battery is in good health and out of 1 year warranty coverage. Battery should continue to function until consumed.	
	No	Battery is consumed after warranty coverage. Customer to purchase a new battery.	
16. For batteries still covered by warranty, is the health of the battery "Good?"	Yes	Battery functioning normal. Go to step 17.	
	No	Battery has premature capacity loss. Replace customer battery.	P08
17. With battery charge greater than 20% does battery support system operation without AC connected?	Yes	Customer battery is good	
	No	Go to step 18	
18. Test with a known-good battery. Does known-good battery support battery only operation?	Yes	Replace customer battery for will not run system on battery alone	P12
	No	Replace logic board	M20

Kernel Panic/System Crashes

Unlikely cause: Battery, Power Adapter

Quick Check

Symptom	Quick Check
Memory Issues/Kernel panic and freezes <ul style="list-style-type: none"> • Display notice of system kernel panic during start up and desktop use. • System freeze during use. • System freeze upon wake from sleep. 	<ol style="list-style-type: none"> 1. Reset SMC and clear PRAM 2. Remove suspect external devices. 3. Verify user memory is Apple-approved memory, and memory configuration matches memory installed. 4. Start up with shift key down for safe mode. 5. Startup from known-good bootable device 6. Check panic.log info for crash cause 7. Run AHT for sensors test



Deep Dive

Check	Result	Action	Code
1. Isolate Peripherals as cause. Disconnect all peripherals, external devices, and display adapters if present	Yes	Suspect peripherals as cause. Reconnect one at a time, verifying unit operation at each stage	
	No	Go to Step 2	
2. Reset SMC and clear PRAM then verify that unit starts without panic issues.	Yes	Issue resolved with default startup settings.	
	No	Go to step 3	
3. Boot in Safe Mode with Shift key down, and check for recent kernel panic data in panic log. Open Panic.log file on hard drive and check for affected interface that crashed. If unit still crashes during startup, you will need to take out disk to a good system to access the file. Verify that kernel panic dependency is not with an I/O interface.	Yes	Kernel Panic is not a system I/O related device. Go to step 5	
	No	I/O device related crash, go to step 4	



<p>4. Remove I/O device where possible to pinpoint faulty device:</p> <ul style="list-style-type: none"> - Disconnect camera cable from display assembly (for AirPort, Bluetooth, camera, and ambient light sensor). Camera cable can be disconnected without affecting startup and test. - Bluetooth card to isolate Bluetooth. - optical drive cable to isolate optical drive. - hard drive cable to isolate hard drive. <p>Memory cards can be removed, relocated, or tested with known-good memory. Because system will run on one card, this is a useful test for finding bad memory or bad memory slot.</p> <p>If issue remains after testing I/O device, replace with known-good part(s) to confirm issue resolved.</p>	Yes	<p>System starts up when I/O device removed, replace affected I/O device or module containing it.</p> <p>If AirPort card presence is crashing system, replace AirPort card. If still issue, replace display assembly (for Bluetooth, camera, or cable damage).</p> <p>If Bluetooth card presence is crashing system, replace Bluetooth. If issue remains, replace display assembly for damaged Bluetooth (camera) cable.</p> <p>If optical drive presence is crashing system, replace optical drive cable and retest. If issue remains try with known-good optical drive. If still issue, replace optical drive.</p> <p>If hard drive presence is crashing system, replace hard drive cable and retest. If issue remains, try with known-good hard drive. If still issue, replace hard drive.</p> <p>Reseat memory or replace suspect memory with known-good memory.</p>	<p>N13 L14</p> <p>N15 or L16</p> <p>X03 J03</p> <p>X03 H01</p> <p>X01</p>
	No	Symptoms unchanged, go to step 5	
<p>5. Start up from optical drive or known-good OS. Attempt to start up with original or product install disc, or from an external hard drive with product OS installed, and verify that system starts without kernel panic.</p>	Yes	Kernel panics cease running alternate OS. Run ASD/ DiskUtility to repair and test hard drive. If repair attempts fail, repartition hard drive and reinstall OS. Replace hard drive if restore fails.	H03
	No	Symptoms unchanged, go to Step 6	



6. Disconnect display assembly and test with known-good display assembly. Verify that system now starts up without kernel panic/freeze.	Yes	Replace display assembly.	L14
	No	Go to step 7	
7. Check for thermal values and fan running speed Run ASD to check for fan and sensors test, and verify that ASD does not report any overtemp, failing sensor, or fan.	Yes	No thermal fail detected - Replace logic board with matching symptom: - If hang or freeze - If Kernel Panic/system crashes	M05 M06
	No	If sensor test failed, reseal sensor connections on logic board and retest. If still failing, replace sensor or part where it is located (top case, display, other) : If top case sensor failed If display sensor failed If logic board sensor failed If fan test failed, replace fan. If overtemp , replace heatsink.	X99 L14 M18 X03 X10

Battery Run Time Too Short

Quick Check

Symptom	Quick Check
Battery Run Time Too Short Battery runs out of power very quickly (less than two hours)	<ol style="list-style-type: none"> 1. Check if the battery is covered under a repair extension program. Use the "Portable Computer Battery Screening Process for Apple Service Providers" (Knowledge Base CP165). 2. Verify no applications have runaway processes with the CPU. See "Runaway applications can shorten battery runtime" (Knowledge Base TS1473). 3. Run battery diagnostic testing..



Won't Run on Power Adapter Alone

Unlikely cause: RAM, display assembly, hard drive, optical drive, top case, speakers, camera, microphone

Quick Check

Symptom	Quick Check
Won't Run on Power Adapter Alone Runs on battery but not on power adapter only.	<ol style="list-style-type: none"> 1. Verify proper wattage adapter is being used. 2. Check for dirty or stuck pins on the MagSafe connectors, both on the adapter and the computer. 3. Connect the AC adapter to known-good power source. 4. Verify power cord or plug is properly attached to AC adapter and MagSafe cable is not damaged.

Deep Dive

Check	Result	Action	Code
1. With battery removed, will a known-good AC adapter start up and run the system and show MagSafe LED status?	Yes	Confirm user's AC adapter as bad and replace.	P14
	No	Verify MagSafe board cable seating to logic board. Go to step 2	
2. Does a known-good power adapter's LED light up either green or amber?	Yes	SMC on logic board senses AC power adapter. Go to step 3	
	No	Replace the MagSafe board. Go to step 3.	
3. Does the unit run on known-good power adapter alone?	Yes	Issued resolved.	X03
	No	Replace logic board..	M01



Power Adapter Issue

Unlikely cause: logic board, RAM, display assembly, hard drive, optical drive, top case, speakers, camera, microphone

Quick Check

Symptom	Quick Check
Power Adapter Issue <ul style="list-style-type: none"> No power No Power LED Non-operational Stuck /broken pin 	<ol style="list-style-type: none"> Connect AC adapters MagSafe connector to the computer. The LED on the connector should be green or amber. Verify power cord, or plug, is firmly attached to AC adapter. Verify AC power source is supplying AC power. Check for dirty or stuck pins on the MagSafe connectors, both on the adapter and the computer. Use and cleaning of power adapter with MagSafe

Deep Dive

Check	Result	Action	Code
1. Verify that the MagSafe LED is green or amber while connecting a known-good AC adapter on customer system.	Yes	SMC on logic board senses AC power adapter and enabled power. Go to step 4.	
	No	Verify MagSafe interconnect board is connected to logic board. Go to step 2	
2. Does the unit run on known-good AC power adapter only?	Yes	Issued resolved.	P99
	No	Replace the MagSafe interconnect board. Go to step 3.	
3. Verify the MagSafe LED is green or amber while connecting known-good power adapter on customer system.	Yes	Bad MagSafe interconnect board. Issue resolved.	X03
	No	Go to step 4	



4. Does the customer's power adapter have stuck or bent pins on the MagSafe connector?	Yes	Replace power adapter.	P15
	No	Go to step 5	
5. Does the cable or duckhead have visible damage?	Yes	Replace cable or duckhead.	P16
	No	Go to step 6	
6. Check that LED on MagSafe connector is displaying both green (if battery charged) and orange (when charging).	Yes	Verify adapter with known-good unit and customer unit and troubleshoot source of error	
	No	Replace power adapter.	P03

Noise / Hum / Vibration

Unlikely cause: RAM, display assembly, top case, camera, microphone, battery

Quick Check

Symptom	Quick Check
Noise / Hum / Vibration Computer or AC adapter emits a noise or vibration.	<ol style="list-style-type: none"> 1. Verify and reproduce the source of the noise from the computer / adapter with the customer. 2. If the AC adapter is the source of the noise disconnect and try a known-good adapter. (a small amount of hum or vibration is normal with AC adapters).

Deep Dive

Check	Result	Action	Code
1. Use of a known-good AC adapter eliminates the noise/ vibration.	Yes	Replace AC adapter.	P04
	No	Go to step 2	
2. Verify if the noise is heard through the speakers and / or headphones.	Yes	Go to step 3	
	No	Go to step 4	



3. Disconnect any peripheral devices, cards, or cables attached to the unit. Verify the noise is gone.	Yes	Check for possible ground loop.	
	No	Go to step 6	
4. Locate the source of the noise. Is the noise from an optical drive?	Yes	Check with a different media disc. Possible issue with disc label or out of balance media. If not related to media, and noise is above normal level, replace optical drive.	J04
	No	Go to step 5	
5. Is the noise from the hard drive?	Yes	It is normal for drives to produce noise when they spin up or the heads move. Replace drive if noise is above normal levels.	H06
	No	Go to step 6	
6. Is the noise coming from the fan?	Yes	The fan(s) are generally running in a slow mode, but may accelerated when intensive processing is required (calculation, 3D gaming, or screen saver animation). If still beyond expected sound level, check for interference of fan with other mechanical element of system (foam, bracket, shield) before replacing a noisy fan.	X03
	No	Go to step 7.	P04
7. Noise maybe related to interference from other electrical devices operating near the computer, or on the same AC power source. Verify if noise is gone when operating in a different location on a different AC circuit.	Yes	Perhaps operating the unit with a surge suppressor will eliminate or reduce the noise. Change location of use or limit use of other device that is inducing the noise.	
	No	Replace logic board.	M99



Burnt Smell / Odor

Unlikely cause: Enclosure

Quick Check

Symptom	Quick Check
Burnt Smell / Odor Computer or power adapter emits an odor or smell of smoke.	<ol style="list-style-type: none"> 1. Disconnect AC adapter from the computer. 2. Attempt to identify the source of the odor. Visual clues are component damaged like capacitor chip popped or burn marks.

Deep Dive

Check	Result	Action	Code
1. Has the source of the odor been identified.	Yes	Replace the affected part.	P08
	No	Go to step 2	
2. Are any burn marks visible on components?	Yes	Remove display assembly and clutch cover. An improperly seated cable, a damaged cable, or a reversed AirPort Card connection can blow components near the connector on the logic board. Is AirPort Card cable correctly oriented and connected? If so, replace the damaged part. If not, reseal the AirPort cable correctly and replace the damaged logic board.	P08
	No	Go to step 3	



3. Is the computer operating normally?	Yes	This could be related to normal operation.	
	No	Please refer to best related troubleshooting section. If after inspecting the unit you feel there is a possible safety issue with the computer or AC adapter, please notify Apple.	

Battery Leaking or Swollen

Quick Check

Symptom	Quick Check
Battery Leaking or Swollen <ul style="list-style-type: none"> • Computer wobbles • Trackpad button does not work • Deformed bottom case 	<ol style="list-style-type: none"> 1. Check if the battery is covered under a repair extension program. Reference: MacBook, MacBook Pro (15-inch) or MacBook Pro (17-inch) with swollen battery article (Knowledge Base TS2358). 2. Use the “Portable Computer Battery Screening Process for Apple Service Providers” (Knowledge Base CP165) and use “Battery pack is visibly deformed” case under section 2E. Use symptom code P13.

Uncategorized Symptom

Quick Check

Symptom	Quick Check
Uncategorized Symptom Unable to locate appropriate symptom code	Verify whether existing symptom code applies to the issue reported by the customer. If not, document reported symptom and send feedback to smfeedback@apple.com stating that a suitable symptom code could not be found.



Communications

Ethernet Port/Device Issue

Unlikely cause: power adapter, battery, speakers, optical drive, hard drive, fan, camera, microphone, top case, display assembly, AirPort card

Quick Check

Symptom	Quick Check
Ethernet Port/Device Issue <ul style="list-style-type: none"> No Ethernet device present Unable to access network resources Ethernet device shows no connection Ethernet device unable to get an IP address Slow network performance 	<ol style="list-style-type: none"> Check the network cable for damage, try a known good Ethernet cable – CAT5 or better recommended for 100Mbps+ connections. Check Ethernet ports on Mac and wall/switch for dust, debris, damage or bent pins. Ensure distance from networking infrastructure is less than 300 feet / 105 meters. Verify port, cable and network hardware with a known good system. Isolate firewall, MAC address filtering or hardware access control devices. Check system logs. Isolate OS by starting up from original install media (10.5.x) or compatible known good OS.

Deep Dive

Check	Result	Action	Code
1. Visually inspect Ethernet connector to ensure all pins will make physical contact with CAT5 network cable.	Yes	Ethernet interface contacts are good. Go to step 2.	
	No	Pins are damaged or bent flat, replace logic board.	M10
2. Isolate OS by booting from original install media. Verify Network Link status active by using Network Utility on install DVD. If the Ethernet interface (en0) Link Status is inactive, recheck physical connect and link activity indicator on hub/switch.	Yes	Ethernet interface (en0) Link Status is active, go to step 3.	
	No	If connection is OK on known-good system, replace logic board.	M10



3. Verify if IP address is listed for the Ethernet interface in System Preferences: Network. Connect computer to network with known-good DHCP IP allocation, ensuring static DHCP maps or filtering is not preventing address allocation. Note: DHCP allocation may not be instantaneous depending on network. Retest.	Yes	Go to step 4.	
	No	If connection is OK on known-good system, replace logic board.	M10
4. Verify connection by using Network Utility to ping another connected computer on the same subnet. Ensure the target computer's IP address is valid, on the same subnet and powered on. Ensure no MAC address filtering or hardware access control devices are present. Use a simple hub/switch environment.	Yes	Go to step 5	
	No	If the symptoms do not change, replace the logic board.	M10
5. Verify Ethernet performance and reliability by starting up from a known-good OS install, and downloading a large file from a web site or file server.	Yes	If there is no performance or connectivity issue isolated solely to the system under test, the problem may be the network environment. No repair is necessary.	
	No	If there are connection dropouts or poor performance not seen on a known-good test system, replace the logic board.	M10



AirPort/Bluetooth: Defective Wireless Devices

Unlikely cause: power adapter, battery, speakers, optical drive, hard drive, fan, camera, microphone, top case

Caution: When testing an AirPort card connection, wait at least 5 seconds after shutdown before touching the camera cable connection to the logic board. Waiting less than that could damage the AirPort card.

Quick Check

Symptom	Quick Check
AirPort or Bluetooth: Defective Wireless Devices <ul style="list-style-type: none"> • Unable to join networks or pair devices • Card not available or recognized • Intermittent device or connection dropouts 	<ol style="list-style-type: none"> 1. Open System Preferences and make sure AirPort or Bluetooth is turned on and (for AirPort) that a network is selected. 2. Check that base station is not using unsupported connection and encryption protocols. 3. Check for nearby interference sources such as microwave ovens or cordless phones (Knowledge Base HT1365) 4. Check the number of users trying to use AirPort in the area for possible network congestion. 5. Isolate OS by booting from original install media (10.5.x). Attempt to connect to base station (AirPort) or pair with wireless keyboard (Bluetooth). 6. Reset PRAM.

Deep Dive

Check	Result	Action	Code
<ol style="list-style-type: none"> 1. Open System Profiler, check to see if AirPort or Bluetooth is recognized. Ensure software and firmware updates for AirPort and Bluetooth have been applied. 	Yes	(AirPort) Ensure MAC address filtering is not enabled on the base station. (Bluetooth) Ensure target devices are set to discoverable.	
	No	If card is not detected or software updates do not resolve issue, go to step 2.	



2. Run Clamshell Service Diagnostic utility and check for all devices presence. If not found, reseal the camera cable connection to the logic board.	Yes	Loose logic board connection.	N04
	No	AirPort issue, go to step 3, Bluetooth issue go to step 7.	
3. (AirPort) Verify the antenna connections to the AirPort card are not reversed or loose. Reseat antenna and I/O cable connections.	Yes	Loose connections or crossed antenna.	N04
	No	If the connectors are secure, antenna connections not reversed and show no signs of damage or wear, go to step 4.	
4. (AirPort) Try a known-good AirPort antenna.	Yes	Replace AirPort antenna.	N14
	No	Continue to use known-good antenna, go to step 5.	
5. (AirPort) Try a known-good AirPort card.	Yes	Replace AirPort card.	N12
	No	Go to step 6.	
6. (AirPort) Try a known-good display assembly if available.	Yes	Replace display assembly.	L16
	No	Replace logic board.	M11
7. (Bluetooth) Enable Bluetooth and try a known-good Bluetooth card. Although Bluetooth cabling is part of camera cable, Bluetooth card is separate. Verify that System Profiler sees known-good Bluetooth card.	Yes	Replace Bluetooth card.	N15
	No	Go to step 8.	
8. (Bluetooth) Enable Bluetooth and try a known-good display assembly, if available, and Bluetooth card. Bluetooth cabling is part of camera cable. Verify that System Profiler sees known-good Bluetooth card.	Yes	Replace display assembly.	L16
	No	Replace logic board.	M11



No/Poor Wireless Signal

Unlikely cause: power adapter, battery, speakers, optical drive, hard drive, fan, camera, microphone, top case

Quick Check

Symptom	Quick Check
No/Poor Wireless Signal <ul style="list-style-type: none"> • Unable to find networks • Intermittent connection dropouts • Slow transfer speeds 	<ol style="list-style-type: none"> 1. Check for nearby interference sources in the 2.4/5GHz range such as microwave ovens and cordless phones (Knowledge Base HT1365). 2. Check that computer is within base station range – move closer to base station. 3. Base station checks: <ol style="list-style-type: none"> a. Base station is not set to low-power transmission mode b. Base station is not using unsupported connection and encryption protocols c. Check for possible Wi-Fi channel overlap (nearby base stations using adjacent channel) 4. Isolate OS by booting from original install media (10.5.x). Attempt to connect to base station.

Deep Dive

Check	Result	Action	Code
1. Open System Profiler, check to see if AirPort card is recognized under Network: AirPort Card.	Yes	Use Software Update to make sure all AirPort software and firmware updates have been applied. Ensure base station is not using MAC address filtering or creating a hidden network.	
	No	If card is not detected, go to M11 - AirPort/Bluetooth - Defective wireless devices.	
2. Run Clamshell Service Diagnostic utility and check for all devices presence. If not found, reseal the camera cable connection to the logic board.	Yes	Loose logic board connection	N04
	No	Go to step 3.	



3. Verify the antenna connections to the AirPort card are not reversed or loose. Reseat antenna and I/O cable connections.	Yes	Loose connections or crossed antenna	N04
	No	If the connectors are secure, antenna connections not reversed and show no signs of damage or wear, go to step 4.	
4. Try a known-good AirPort antenna.	Yes	Replace AirPort antenna.	N14
	No	Continue to use known good antenna, go to step 5.	
5. Try a known-good AirPort card.	Yes	Replace AirPort card.	N12
	No	Continue to use known-good antenna & card; go to step 6.	
6. Try a known-good display assembly if available.	Yes	Replace display assembly.	L16
	No	Replace logic board.	M11

Bluetooth Wireless Input Device Loses Connection

Unlikely cause: display assembly, speaker assembly, optical drive, hard drive

Quick Check

Symptom	Quick Check
Bluetooth Wireless Input Device Loses Connection	Check Bluetooth input device has fully charged batteries.

Deep Dive

Check	Result	Action	Code
1. System Profiler should list Bluetooth radio device under system hardware. Is Bluetooth device available?	Yes	Bluetooth radio present, verify Bluetooth preference settings, go to step 2.	
	No	Attempt Bluetooth repair, go to step 5.	



2. System Preferences has a Bluetooth panel. Ensure Bluetooth is on and discoverable. Are there any devices listed in pairing window?	Yes	Choose known-good device and establish a connection. Go to step 3.	
	No	Attempt Bluetooth repair, go to step 5.	
3. Ensure a known-good Bluetooth device is on, in close range and in discoverable mode. Is computer pairing with known-good device?	Yes	Pairing verified, connect with user's device, go to step 4	
	No	Attempt Bluetooth repair, go to step 5.	
4. Is computer pairing with user's Bluetooth device?	Yes	Connection established, continue testing for connection loss, go to step 8.	
	No	Check for software updates for both computer & device.	K07
5. Run Clamshell Service Diagnostic utility and check for all devices presence. If not found, reseal camera cable on logic board. Verify that a USB Bluetooth controller is visible in System Profiler.	Yes	Loose cable connection.	N04
	No	Go to step 6.	
6. Install a known-good Bluetooth card. Verify that a USB Bluetooth controller is visible in System Profiler.	Yes	Replace Bluetooth card	N15
	No	Go to step 7	
7. Install and test a known-good display assembly. Verify that a USB Bluetooth controller is visible in System Profiler.	Yes	Replace display assembly.	L16
	No	Replace logic board.	M11



8. Continue to test a known-good Bluetooth device to determine if there is a disconnect. Do not allow computer to sleep during this test. Is link lost during test?	Yes	Check for software update, 2.4 GHz radio interference or device low battery. If still losing link, replace Bluetooth card. If installed Bluetooth card is known-good or was already replaced, replace top case (for Bluetooth antenna).	N14 N14
	No	Known-good device passed test.	

AirPort Card: Kernel Panic

Unlikely cause: power adapter, battery, speakers, optical drive, hard drive, fan, camera, microphone, top case

Quick Check

Symptom	Quick Check
AirPort Card: Kernel Panic <ul style="list-style-type: none"> Kernel panic on boot Kernel panic or freezing while attempting to connect to Wi-Fi networks Kernel panic while transferring data on Wi-Fi networks. 	<ol style="list-style-type: none"> Isolate OS by booting from original install media (10.5.x). Attempt to connect to Wi-Fi network. Use Software Update to make sure all AirPort software and firmware updates have been applied.

Deep Dive

Check	Result	Action	Code
1. Use Software Update to make sure all AirPort/Bluetooth software and firmware updates have been applied. Ensure MAC address filtering is not enabled on the base station. Is kernel panic resolved?	Yes	Software issue.	
	No	Go to step 2.	



2. Run Clamshell Service Diagnostic utility and check for all devices presence. If not found, reseal the camera cable connection to the logic board. Is kernel panic resolved?	Yes	Go to step 4.	
	No	Go to step 3.	
3. Isolate AirPort card by removing the I/O connection from the AirPort card. side. Reconnect camera cable connection to logic board. Is kernel panic resolved?	Yes	Go to step 4.	
	No	Go to M06 Kernel Panic / System Crashes.	
4. Connect and test with a known-good AirPort card. Is kernel panic resolved?	Yes	Replace AirPort card.	N13
	No	Replace display assembly.	L16



Wireless Performance Issue / Slow Connection

Unlikely cause: power adapter, battery, speakers, optical drive, hard drive, fan, camera, microphone, top case

Quick Check

Symptom	Quick Check
Wireless Performance Issue / Slow Connection <ul style="list-style-type: none"> • Slow or stalled data transfers • Intermittent connection dropouts 	<ol style="list-style-type: none"> 1. Check for nearby interference sources in the 2.4/5GHz range such as microwave ovens or cordless phones (Knowledge Base HT1365) 2. (AirPort) Check the number of users trying to use AirPort in the area for possible network congestion. Move closer to base station to improve signal reception. 3. (Bluetooth) Move devices closer together. 4. Check performance with a known-good system 5. (AirPort) Wireless base station checks: <ol style="list-style-type: none"> a. Base station is not set to low-power transmission mode. b. Base station is not set to a slower protocol mode (802.11b). c. Check for possible Wi-Fi channel overlap (nearby base stations using adjacent channel). 6. Isolate OS by booting from original install media (10.5.x). Attempt to connect to base station (AirPort) or pair with wireless keyboard (Bluetooth) 7. Use Software Update to make sure all AirPort and Bluetooth software and firmware updates have been applied.

Deep Dive

Check	Result	Action	Code
1. Inspect the display clutch barrel for damage. AirPort radio is in display clutch barrel area.	Yes	Record damage: Proceed to possibly repair damaged parts, go to step 2	
	No	No visible damage, go to step 2	



2. Turn off Bluetooth. Retest AirPort performance. Refer to Knowledge Base TS1809 .	Yes	Possible AirPort interference from the Bluetooth card. Change AirPort base station channel. (Knowledge Base TS1809 .)	N06
	No	Continue by checking connections, go to step 3	
3. Run Clamshell Service Diagnostic utility and check for all devices presence. If not found, reseal the camera cable connection to the logic board.	Yes	Loose logic board connection	N04
	No	AirPort issue, go to step 4, Bluetooth issue, go to step 8.	
4. (AirPort) Verify the antenna connections to the AirPort card are not reversed or loose. Reseat antenna and I/O cable connections.	Yes	Loose connection or crossed antenna	N04
	No	If the connectors are secure, antenna connections not reversed and show no signs of damage or wear, go to step 5	
5. (AirPort) Try a known-good AirPort antenna and verify that issue is fixed..	Yes	Replace AirPort antenna.	N14
	No	Continue to use known good antenna, go to step 6.	
6. (AirPort) Try a known-good AirPort card and verify that issue is fixed..	Yes	Replace AirPort card.	N12
	No	Continue to use known-good antenna & card, go to step 7.	
7. (AirPort) Try a known-good display assembly if available and verify that issue is fixed..	Yes	Replace display assembly.	L16
	No	Replace logic board.	M11
8. (Bluetooth) Enable Bluetooth and try a known-good Bluetooth card if available. Verify that Bluetooth is pairing with known-good device.	Yes	Replace Bluetooth card.	N15
	No	Go to step 9.	



9. (Bluetooth) Enable Bluetooth and try a known-good antenna assembly if available. Verify that pairing issue is fixed.	Yes	Replace top case.	N14
	No	Go to step 10.	
10. (Bluetooth) Enable Bluetooth and try a known-good display assembly if available. Verify that Bluetooth is pairing with known-good device.	Yes	Replace display assembly.	L16
	No	Replace logic board.	M11

Wireless Input Device Doesn't Pair

Unlikely cause: display assembly, logic board, optical drive, hard drive

Quick Check

Symptom	Quick Check
Wireless Input Device Doesn't Pair <ul style="list-style-type: none"> Can't get the system to recognize the Bluetooth keyboard or mouse 	<ol style="list-style-type: none"> Check Bluetooth System Preference is set to Discoverable. Check Bluetooth device has fully charged batteries. Check for Bluetooth software updates for both the device and Mac OS X. If the Bluetooth pairs with no problems, probe about potential interference issue at user's site.

Deep Dive

Check	Result	Action	Code
1. System Profiler should list Bluetooth radio device under system hardware. Is Bluetooth device available?	Yes	Bluetooth radio present, verify Bluetooth preference settings, go to step 2.	
	No	Attempt Bluetooth repair, go to step 5.	



2. System Preferences has a Bluetooth panel. Ensure Bluetooth is on and discoverable. Are there any devices listed in pairing window?	Yes	Choose known-good device and establish a connection. Go to step 3.	
	No	Attempt Bluetooth repair, go to step 5.	
3. Ensure a known-good Bluetooth device is on, in close range and discoverable mode, Is system pairing with known-good device?	Yes	Pairing verified, connect with user's device, go to step 4.	
	No	Attempt Bluetooth repair, go to step 5.	
4. Is Bluetooth pairing with user's Bluetooth device?	Yes	Issue resolved.	
	No	Check for SW update for both System and user device.	
5. Run Clamshell Service Diagnostic utility and check for all devices presence. If not found, reseal camera cable with logic board. Is the Bluetooth radio present, on and pairing with a known-good device?	Yes	Bad logic board connection. Issue resolved.	
	No	Go to step 6.	
6. (Bluetooth) Enable Bluetooth and try a known-good Bluetooth card if available. Is pairing issue fixed?	Yes	Replace Bluetooth card.	N15
	No	Go to step 7.	
7. (Bluetooth) Enable Bluetooth and try a known-good antenna assembly if available. Is pairing fixed?	Yes	Replace top case.	N14
	No	Go to step 8.	
8. (Bluetooth) Enable Bluetooth and try a known-good display assembly if available. Is Bluetooth pairing with a known-good device?	Yes	Replace display assembly.	L16
	No	Replace logic board.	M11



Uncategorized Symptom

Quick Check

Symptom	Quick Check
Uncategorized Symptom Unable to locate appropriate symptom code	Verify whether existing symptom code applies to the issue reported by the user. If not, document reported symptom and send feedback to smfeedback@apple.com stating that a suitable symptom code could not be found.



Display

Display Anomalies

Quick Check

Symptom	Quick Check
Display Anomalies <ul style="list-style-type: none"> • Incorrect/missing colors • Distorted/blurred image • Pixel anomalies • Vertical/horizontal lines • Non-uniform brightness • Image flicker • Image persistence 	<ol style="list-style-type: none"> 1. Allow display to reach normal operating temperature for about 15 minutes before evaluating front-of-screen performance. 2. Check display preferences for use of custom display profile. 3. Check brightness setting. 4. Check for Software Updates. 5. Clean glass panel while checking for dust/debris. 6. Go to Deep Dive: General

Deep Dive: General

Check	Result	Action	Code
1. Verify if user's issue is incorrect/missing colors.	Yes	Go to Incorrect/Missing Colors Deep Dive .	
	No	Go to step 2.	
2. Verify if user's issue is distorted/blurred image.	Yes	Go to Distorted/Blurred Image Deep Dive .	
	No	Go to step 3.	
3. Verify if user's issue is bright or dark pixel anomalies.	Yes	Go to Pixel Anomalies Deep Dive .	
	No	Go to step 4.	
4. Verify if user's issue is vertical or horizontal lines.	Yes	Go to Vertical/Horizontal Lines Deep Dive .	
	No	Go to step 5.	
5. Verify if user's issue is non-uniform brightness.	Yes	Go to Non-uniform Brightness Deep Dive .	
	No	LCD functioning OK.	



Deep Dive: Incorrect/Missing Colors

Check	Result	Action	Code
1. Verify display is listed in the System Profiler's Graphics/Displays device tree.	Yes	This ensures color profile can be matched with LCD. Go to step 2.	
	No	Go to N09.	
2. Verify System Preferences Display Profile is valid for display being tested. Color profile should be set to Color LCD, user may have created an off-color calibration setting.	Yes	If display profile is valid and the colors are still incorrect or missing go to step 3.	
	No	Set System Preferences: Displays: Color to Color LCD and retest.	
3. Verify that the glass panel is free of contaminants.	Yes	Go to step 4.	
	No	Clean glass panel using approved method. Retest.	
4. Run Clamshell Service Diagnostic utility and check for LCD panel presence. If not found, reseal and verify LVDS cable is secure to the logic board. Are colors restored?	Yes	Loose cable connection. Issue resolved.	
	No	Go to step 5.	
5. Set desktop pattern in System Preferences to 'Solid Gray Light'. Verify if incorrect/missing color issue affects entire display.	Yes	Test a known-good display, go to step 7.	
	No	Go to step 6.	
6. Set up display under test side by side with another known good display showing the same image. Verify if issue is noticeably worse on the display being tested.	Yes	Test a known-good display, go to step 7	L02
	No	Small variations in color uniformity are normal and do not warrant replacement or repair of the display.	
7. Substitute a known-good display assembly to test logic board video output. Is normal video restored?	Yes	Replace display assembly.	L02
	No	Replace logic board.	M04

Deep Dive: Distorted/Blurred Image

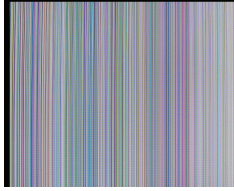

Check	Result	Action	Code
1. Sample image illustrates loss of LVDS data signals to LCD or a defective LCD panel. Inspect & reseal LVDS cable connection looking for damaged or bent pins. Is image restored with reseated cable connection?	Yes	Issue due to loose connection. Display issue resolved.	
	No	Go to step 2.	
2. Substitute a known good display assembly to test logic board video output. Is normal video restored?	Yes	Replace display assembly.	L04
	No	Replace logic board.	M04

Deep Dive: Pixel Anomalies

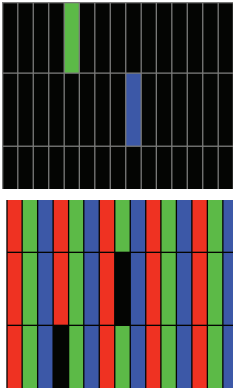

Check	Result	Action	Code
1. Determine if “defects” are dust/debris on surface of glass panel.	Yes	Clean glass panel.	
	No	Go to step 2.	
2. Determine if bright pixel defects exceed the acceptable number. See Display Issue: Pixel Anomalies .	Yes	Replace display assembly.	L08
	No	LCD meets bright pixel defect specifications. Go to step 3.	
3. Determine if dark pixel defects exceed the acceptable number. See Display Issue: Pixel Anomalies .	Yes	Replace display assembly.	L08
	No	LCD meets dark pixel defect specifications. Go to step 4.	
4. Determine if the combination of bright/dark pixel defects exceed the acceptable number. See Display Issue: Pixel Anomalies .	Yes	Replace display assembly.	L08
	No	Explain to user that LCD is within specifications. Do not replace display assembly.	

Deep Dive: Vertical/Horizontal Lines

Check	Result	Action	Code
-------	--------	--------	------

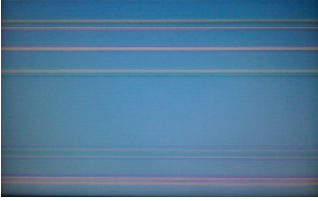

1. Horizontal lines may be related to a failing RAM module. Verify if video issue only happens AFTER the Apple logo and the spinning wheel has appeared.	Yes	Issue only happens AFTER Apple logo and spinning wheel appears. Go to step 2.	
	No	Issues happens since startup. Go to step 5.	
2. Start with shift key down (safe mode) to disable system extensions. Verify if issue still happens when booting in safe mode.	Yes	Go to step 5.	
	No	No video issue when booting in safe mode. Go to step 3.	
3. Isolate with only one memory module installed , then with the other one. Test with known-good memory. Verify that issue only happens with specific RAM module(s).	Yes	Replace affected RAM module.	X02
	No	Go to step 4	
4. Isolate with one known-good memory module installed in one of the memory slots. Repeat by testing in the other memory slot with known-good memory module. Verify that issue only happens with specific memory slot on logic board.	Yes	Replace logic board.	M07
	No	Go to step 5	
5. Run Clamshell Service Diagnostic utility and check for LCD panel presence. If not found, reseal the LVDS cable to the logic board video output. Is normal video restored?	Yes	Issue resolved by reseating loose LVDS cable..	
	No	Go to step 6	
6. Connect external compatible DisplayPort display (or DisplayPort adapter and display). Verify if correct video appears on external display.	Yes	Go to step 7.	
	No	Replace logic board	M04
7. Substitute a known-good display assembly module to test logic board LVDS video output. Is normal video restored?	Yes	Replace display assembly module.	L05
	No	Replace logic board.	M04

Deep Dive: Non-uniform Brightness



Check	Result	Action	Code
1. Determine if brightness uniformity issue is visible after display has warmed up for 15 minutes.	Yes	Go to step 2.	
	No	Display backlight can take several minutes to stabilize.	
2. Check LVDS cable connection to logic board.	Yes	Reseat LVDS cable	
	No	Got to step 3	
3. Determine if variation in uniformity appears excessive when compared to another similar unit.	Yes	Replace display assembly.	L07
	No	Explain to user that LCD appears to meet specifications.	





Defective Camera / Built-in iSight Not Operating Correctly

Quick Check

Symptom	Quick Check
Defective Camera <ul style="list-style-type: none"> • Camera not detected • No green LED for camera • Excessive blooming • Poor white balance • Poor focus • Green image • Image distortion 	<ol style="list-style-type: none"> 1. Check for Software Updates. 2. Verify camera lens and glass panel are clear of contaminants.

Deep Dive

Check	Result	Action	Code
1. Launch System Profiler and confirm that "Built-in iSight" is listed under USB High-Speed Bus.	Yes	Camera recognized. Go to step 3	
	No	Go to step 2.	
2. Run Clamshell Service Diagnostic utility and check for all devices presence. If not found, inspect and reseal camera cable on logic board. Is iSight listed in System Profiler?	Yes	Camera recognized. Go to step 3.	
	No	Go to step 4.	
3. Launch PhotoBooth. Verify that camera's green LED is on and image appears normal.	Yes	Issue resolved..	
	No	Go to step 4.	
4. Substitute a known-good display assembly to test logic board camera connection. Is iSight camera operating properly?	Yes	Replace display assembly.	X11
	No	Replace logic board.	M13



Blank / No Video

Unlikely cause: Power adapter, speakers, ODD/HDD, fan, microphone, top case

Quick Check

Symptom	Quick Check
Blank / No Video <ul style="list-style-type: none"> No video No backlight 	<ol style="list-style-type: none"> Check brightness setting Attach known-good supported external display. Boot from Mac OS X install DVD that came with computer.

Deep Dive

Check	Result	Action	Code
1. Verify boot chime present when system restarted. Reset SMC and clear PRAM if necessary for proper start up. Is LCD video present?	Yes	Go to step 3.	
	No	Go to step 2.	
2. Connect known-good supported external display. Verify whether image appears on external display when system is booted.	Yes	External display detected by system. Go to step 3.	
	No	Go to No Video symptom code flow.	
3. Verify if LCD backlight is on by looking for faint glow from display when viewed in darkened room with brightness adjusted to full.	Yes	Video signal from system to external video is OK, LCD backlight is on. Go to step 5.	
	No	Go to step 4.	
4. Shine bright (low heat) flashlight into the front of LCD. Verify if an image is being displayed.	Yes	Image present but backlight is not on. Check logic board connections. Go to step 5.	
	No	Go to No Video symptom.	
5. Run Clamshell Service Diagnostic utility and check for LCD panel presence. If not found, reseal and verify that the display connections to the logic board are secure. Verify if image is restored after reseating loose connections	Yes	Issue resolved.	
	No	Continue to test with known-good display assembly. Go to step 6.	



6. Verify LCD video works with a known-good display assembly.	Yes	Replace display assembly.	L03
	No	Go to No Video symptom code flow.	

Backlight Issue / No Backlight

Unlikely cause: Power adapter, battery, speaker, ODD/HDD, fan microphone, top case

Quick Check

Symptom	Quick Check
Backlight Issue / No Backlight <ul style="list-style-type: none"> • Display not illuminated • Flashing, unstable or non uniform background lighting • Poor backlight at some or all settings 	Check that brightness setting is above minimum.

Deep Dive

Check	Result	Action	Code
1. Connect external display, clear PRAM to set brightness to default level and verify if Color LCD is listed in the System Profiler's Graphics/Displays device tree.	Yes	Display panel detected by system. Go to step 3.	
	No	Go to step 2.	
2. Run Clamshell Service Diagnostic utility and check for LCD panel presence. If not found, reseal the LVDS cable at the logic board. Repeat verification in System Profiler.	Yes	Display panel detected by system. Go to step 3.	
	No	Go to step 4.	
3. Darken room and verify backlight by detecting if any glow is emitted from the display	Yes	Backlight operating. Go to step 5.	
	No	Go to step 4.	



4. Swap memory with known-good memory to determine if video issue is ram related..	Yes	Reseat or replace defective memory	X01
	No	Go to step 5	
5. Remove logic board and locate F9800 fuse on board. For fuse locations, see kBase #TS3600 . Using an ohmmeter , determine if fuse is burned out.	Yes	Fuse was probably burned out by a short in display cable or connection. Replace both - display assembly AND - logic board.	L09 M25
	No	Replace customer's display assembly. Go to step 6.	L09
6. Verify that display and backlight operations are restored	Yes	Issue resolved	
	No	Backlight issue persists. Replace logic board and reinstall original display assembly.	M25

Noise / Unstable Flickering

Unlikely cause: Top case, battery

Quick Check

Symptom	Quick Check
Noise / Unstable Flickering <ul style="list-style-type: none"> Image flicker Audible noise 	1. Verify known-good source sound file not causing speaker distortion.

Deep Dive

Check	Result	Action	Code
1. Verify if user's issue is due to video flickering coming from display.	Yes	Suspected flickering issue, go to step 2.	
	No	Audible noise issue, go to step 5.	



2. Verify display listed in the System Profiler's Graphics/Displays device tree is not disappearing intermittently (refresh System Profiler to observe).	Yes	Power and LCD panel ID are OK. Go to step 3.	
	No	Go to No Video symptom code flow.	
3. Inspect and reseal the LVDS cable and camera cable connection between display and logic board. Also test if brightness setting is a contributing factor. Has flickering stopped?	Yes	Loose cable connection. Issue resolved.	
	No	Go to step 4.	
4. Substitute a known good display assembly to test logic board video output. Has flickering stopped?	Yes	Replace display assembly.	L06
	No	Replace logic board.	M04
5. Verify source of noise is electrical, not mechanical. Audio noise should not be a concern since LCD components are all solid state devices including LED backlights.	Yes	Noises that are not audible from the normal user position are considered acceptable. Return unit to the user.	
	No	Noise from other source. Go to P04 Noise/Hum/vibration.	

Mechanical/Physical Damage

Quick Check

Symptom	Quick Check
Mechanical/Physical Damage <ul style="list-style-type: none"> • Broken glass • Broken hinge • Stripped screw/head • Stripped screw boss • Dent or scratch to chassis 	<ol style="list-style-type: none"> 1. Determine damage caused by user/technician environment, accidental damage, or abuse. 2. Inform user/technician the failures are not covered by Apple warranties. Refer to http://www.apple.com/legal/warranty



Cosmetic Defects

Quick Check

Symptom	Quick Check
Cosmetic Defects <ul style="list-style-type: none">• Cracked LCD• Scorched or melted LCD• LCD impact damage	<ol style="list-style-type: none">1. Determine damage caused by user/technician environment, accidental damage, or abuse.2. Inform user/technician the failures are not covered by Apple warranties. Refer to http://www.apple.com/legal/warranty

Uncategorized Symptom

Quick Check

Symptom	Quick Check
Uncategorized Symptom Unable to locate appropriate symptom code	Verify whether existing symptom code applies to the issue reported by the user. If not, document reported symptom and send feedback to smfeedback@apple.com stating that a suitable symptom code could not be found.



Mass Storage

Hard Drive Read/Write Issue

Unlikely cause: LCD, speakers, fan, camera, microphone

Quick Check

Symptom	Quick Check
Hard Drive Read/Write Issue Bad Sector/Defective Drive Formatting Issue <ul style="list-style-type: none"> • Cannot save documents • Read/Write error message • Hang when accessing or saving data 	<ol style="list-style-type: none"> 1. Boot from Install DVD. Verify S.M.A.R.T. status of drive using Disk Utility. 2. Repair disk using Disk Utility. 3. Erase disk and reinstall Mac OS using Installer.

Deep Dive

Check	Result	Action	Code
1. Start up from Restore DVD and launch Disk Utility. Is hard drive available for Disk Utility to repair?	Yes	Go to step 2.	
	No	Go to step 3.	
2. Did Disk Utility mount and repair hard drive successfully? Reseat hard drive if necessary.	Yes	Restart computer. Go to step 6.	
	No	If computer has not been verified with a known-good hard drive, go to step 3; otherwise, go to step 7.	
3. Substitute a known-good bootable hard drive, does system start up to desktop?	Yes	Reinstall user's drive, go to step 2.	
	No	Continue to use known-good bootable hard drive to determine root cause. Go to step 4.	



4. After reseating hard drive SATA and logic board connections, does known-good hard drive boot to desktop?	Yes	Reinstall user's drive, go to step 2	
	No	Suspect hard drive SATA cable, go to step 5.	
5. Replace hard drive SATA cable and retest with known-good hard drive.	Yes	Reinstall user's drive, go to step 2.	X03
	No	Replace logic board.	M19
6. Did user's hard drive start up successfully?	Yes	Issue resolved.	
	No	Repair or replace hard drive, go to step 7.	
7. Partition, erase & install Mac OS on user's hard drive. Did install complete without error and start up successfully?	Yes	Issue resolved	
	No	Hard drive appears to be defective, go to step 8.	
8. Replace user's hard drive. Does drive format correctly with a GUID partition map and install Mac OS without errors?	Yes	Issue resolved.	H01
	No	SATA cable verified or replaced and new hard drive installed, replace logic board.	M19

Hard Drive Not Recognized/Not Mounting

Unlikely cause: LCD, speakers, fan, camera, microphone, AirPort

Quick Check

Symptom	Quick Check
Hard Drive Not Recognized/ Mount Drive No Boot <ul style="list-style-type: none"> Flashing question mark Boots to grey screen Boots to blue screen 	<ol style="list-style-type: none"> Use a known-good mouse. Stuck mouse button will not allow boot. Boot from Install DVD. Verify S.M.A.R.T. status of drive using Disk Utility. Repair disk using Disk Utility. Erase disk and reinstall Mac OS using Installer.



Deep Dive

Check	Result	Action	Code
1. Boot from Restore DVD and launch Disk Utility. Is hard drive available for Disk Utility to repair?	Yes	Go to step 2.	
	No	Go to step 3.	
2. Did Disk Utility mount and repair hard drive successfully? Reseat hard drive if necessary.	Yes	Restart computer, go to step 6.	
	No	If computer has not been verified with a known-good hard drive, go to step 3; otherwise, go to step 7.	
3. Substitute a known-good bootable hard drive, does computer start up to desktop?	Yes	Install user drive, go to step 2.	
	No	Continue to use known-good bootable hard drive to determine root cause. Go to step 4.	
4. After reseating SATA and logic board connections, does known-good hard drive start up to desktop?	Yes	Install user drive, go to step 2.	
	No	Suspect hard drive SATA cable, go to step 5.	
5. Replace hard drive SATA cable and retest with known-good hard drive.	Yes	Install user drive, go to step 2.	X03
	No	Replace logic board.	M19
6. Did user's hard drive start up successfully?	Yes	Issue resolved.	
	No	Restore or replace user's hard drive, go to step 7.	
7. Partition, erase & install Mac OS on user's hard drive. Did install complete without error and start up successfully?	Yes	Issue resolved.	
	No	Hard drive appears to be defective. Go to step 8.	
8. Replace user's hard drive. Does drive format correctly with a GUID partition map and install Mac OS without errors?	Yes	Issue resolved.	H01
	No	SATA cable verified or replaced and new hard drive installed, replace logic board.	M19



Hard Drive Noisy

Unlikely cause: LCD, speakers, fan, camera, microphone

Quick Check

Symptom	Quick Check
Hard Drive Noisy <ul style="list-style-type: none"> Noise during start up Noise during operation Noise when drive is copying or saving data 	<ol style="list-style-type: none"> Start up from Install DVD. Verify S.M.A.R.T. status of hard drive using Disk Utility. Repair disk using Disk Utility. Check for reported noise and compare with Knowledge Base article "Apple Portables: Hard Drives and Noise" http://support.apple.com/kb/TS2354

Deep Dive

Check	Result	Action	Code
1. Boot from Restore DVD and launch Disk Utility. Is hard drive available for Disk Utility to repair?	Yes	Go to step 2.	
	No	Replace hard drive or go to H01 Drive not recognized/mount.	
2. Repair disk using Disk Utility and verify it completed successfully	Yes	Restart computer. Go to step 3.	
	No	Go to step 4.	
3. Is hard drive still noisy?	Yes	Remove hard drive and start up from external drive to test fan noise. Go to step 6.	
	No	Issue resolved.	
4. Erase disk and reinstall Mac OS using Installer. Did process complete?	Yes	Restart computer. Go to step 3.	
	No	Replace hard drive. Go to step 5.	H06



5. After installing new hard drive, do you still have drive noise?	Yes	Remove hard drive and start up from external drive to test fan noise. Go to step 6.	
	No	Issue resolved.	
6. After removing hard drive, verify if the system is still noisy.	Yes	Fan noise or optical drive noise likely to be the cause. See ODD Noisy table and Fan failures/Thermal issues table.	
	No	Go to step 7.	
7. Install a known-good hard drive and verify if the noise level is similar to user's hard drive.	Yes	Hard drive noise level is similar to a known-good drive and does not require replacement.	
	No	Replace hard drive. Go to step 5.	H06

Optical Drive Won't Accept/Reject Media

Unlikely cause: LCD, speakers, fan, camera, microphone

Quick Check

Symptom	Quick Check
Optical Drive Won't Accept/Reject Media <ul style="list-style-type: none"> • Cannot insert a disc into the drive • Cannot eject a disc placed into the drive 	<ol style="list-style-type: none"> 1. Use Apple System Profiler ATA section to see if the optical drive appears. If not, see Optical Drive Not Recognized., 2. Restart computer and hold down mouse button or keyboard eject key to cycle optical drive. 3. Inspect optical drive slot for obstructions



Deep Dive

Check	Result	Action	Code
1. Is optical drive listed in the device tree for serial-ATA devices in System Profiler?	Yes	Optical drive has power, inspect disc acceptance. Go to step 5.	
	No	Inspect hardware. Go to step 2	
2. Verify all connections between logic board, flex cable, and optical drive are secure. Visually inspect cables and connectors for any debris, damage, or bent pins. Is optical drive now listed in System Profiler?	Yes	Optical drive has power, inspect disc acceptance. Go to step 5.	
	No	Replace any damaged cables and retest. If connections are good and with no visible cable damage, go to step 3.	X03
3. Disconnect user's optical drive by lifting SATA cable at logic board and connecting a known good optical drive assembly. Is optical drive now listed in System Profiler?	Yes	SATA port functional, reconnect user's optical drive & SATA cable. Go to step 4.	
	No	Replace logic board.	M19
4. Install and test user's optical drive with replacement SATA flex cable. Is optical drive now listed in System Profiler?	Yes	Cable change resolved issue.	X03
	No	Replace the optical drive. (Mechanical damage to optical drive, if found)	J03 (J06)
5. Inspect optical drive slot for disc insert/eject. Is there clearance for disc use?	Yes	Go to step 6.	
	No	Replace damaged optical drive or system top case that interferes with disc use.	J01 (J05) X13
6. Insert known-good disc and test user's optical drive for acceptance of disc. Does disc auto eject?	Yes	Replace the optical drive. (Mechanical damage to optical drive, if found)	J03 (J06)
	No	Go to step 7.	
7. Does disc mount to desktop?	Yes	Go to Eject Test step 8.	
	No	Go to Optical Drive Read/Write Data Error troubleshooting page.	



8. Does disc eject properly from optical drive?	Yes	Issue resolved.	
	No	Replace optical drive or top case that interferes with disc ejection.	J02 X13
9. With replacement flex cable and interconnect board, is disc now recognized?	Yes	Issue resolved.	
	No	Replace optical drive. If drive has already been replaced, then replace logic board.	J03

Optical Drive Read/Write Data Error

Unlikely cause: LCD, speakers, fan, camera, microphone

Quick Check

Symptom	Quick Check
Optical Drive Read/Write Data Error <ul style="list-style-type: none"> • Errors when writing optical media. • Errors when reading optical media. • Hang when accessing or preparing to write data. 	<ol style="list-style-type: none"> 1. Test optical media in another drive of the same type in same type of machine to rule out media issue. 2. Check with known-good discs like the Install discs that came with the computer. 3. For write issues, check with known-good media that performs well in another computer and optical drive of the same type. 4. Check both CD and DVD media. If only one type of media is producing errors, there is a laser issue. (J99)

Deep Dive

Check	Result	Action	Code
1. Is media free to spin without optical drive scraping edge or surface of media?	Yes	Go to step 2.	
	No	Replace optical drive.	J03



2. Can optical drive read both CD and DVD known-good media?	Yes	Go to step 6	
	No	Reading CD only or DVD only indicates laser issue, replace optical drive.	J03
		Optical drive cannot read any media reliably, go to step 3.	
3. Reseat cable connections at logic board and optical drive. Verify that media is now recognized and reads reliably.	Yes	Reseat resolved issue.	X03
	No	Go to step 4.	
4. Disconnect optical drive by lifting SATA cable at logic board and connecting a known-good optical drive. Verify that media is now recognized and reads reliably.	Yes	SATA port functional, reconnect user's optical drive & SATA cable. Go to step 5.	
	No	Replace logic board.	M19
5. Install and test with replacement optical drive SATA flex cable. Verify that media is now recognized and reads reliably.	Yes	Cable change resolved issue.	X03
	No	Replace the optical drive. (Mechanical damage to optical drive, if found)	J03 (J05)
6. Test write data to compatible CD and DVD media. Verify burned media is recognized and reads reliably.	Yes	Issue resolved.	
	No	Replace the optical drive. (Mechanical damage to optical drive, if found)	J03 (J06)



Optical Drive Not Recognized/Mount

Unlikely cause: LCD, speakers, fan, camera, microphone

Quick Check

Symptom	Quick Check
Optical Drive Not Recognized/Mount <ul style="list-style-type: none"> Discs inject and eject, but do not appear in Finder 	<ol style="list-style-type: none"> Use Apple System Profiler ATA section to see if the optical drive appears. Serial-ATA section of Apple System Profiler will show any media inserted. Check Finder Preferences: General and make sure "CD's, DVD's and iPods" is checked under "Show these items on the Desktop." Check both CD and DVD media. If only one type of media is recognized, there might be a laser related issue. (J99)

Deep Dive

Check	Result	Action	Code
1. Is optical drive listed in the device tree for SATA devices in System Profiler?	Yes	Issue resolved.	
	No	Go to step 2.	
2. Verify all connections between logic board, flex cable, optical drive are secure. Visually inspect cables and connectors for any debris, damage, or bent pins. Is optical drive now listed in System Profiler?	Yes	Issue resolved.	
	No	Replace any damaged cables and retest. If connections are good and with no visible cable damage, go to step 3.	X03
3. Disconnect optical drive by lifting SATA cable at logic board and connecting a known-good drive. Is optical drive now listed in System Profiler?	Yes	SATA port functional, reconnect user's optical drive & SATA cable. Go to step 4.	
	No	Replace logic board.	M19
4. Install and test with replacement optical drive SATA flex cable. Is optical drive now listed in System Profiler?	Yes	Cable change resolved issue	X03
	No	Replace the optical drive. (Mechanical damage to optical drive, if found)	J03 (J05)



Optical Drive Noisy

Unlikely cause: LCD, speakers, fan, camera, microphone

Quick Check

Symptom	Quick Check
Optical Drive Noisy <ul style="list-style-type: none"> Noise during boot Noise during operation Noise when drive is copying or writing data 	<ol style="list-style-type: none"> Test optical media in another drive of the same type in same type of computer to rule out media issue. Check with known-good discs. Install discs that came with the computer. Check to see if noise occurs without media in the drive. If so, check for hard drive (H06) and fan (M18) caused noise.

Deep Dive

Check	Result	Action	Code
1. Is optical drive constantly seeking or cycling eject mechanism without an optical disc installed? Optical drive should perform only one reset sequence and rest idle, ready for media.	Yes	Continue and verify with media, go to step 2.	
	No	Replace optical drive if continuous activity occurs with no disc installed.	J04
2. Insert known good data CD. Is media free to spin without optical drive scraping edge or surface of media? Verify disc does not exceed maximum thickness specification.	Yes	Continue and verify with media, go to step 3.	
	No	Internal mechanical interference is affecting rotational spin of media, replace optical drive.	J04
3. Initial disc handling noise is normal. Disc spinning and head seek indicate disc is mounting to desktop. Seek noise should settle down once mounted. Is noise above normal and related to seek activity?	Yes	Replace optical drive.	J04
	No	Go to step 4.	



4. Disc spin should cease 30 seconds after mounting data CD on OS desktop. Is the noise related to disc spin?	Yes	Go to step 5.	
	No	Go to step 6.	
5. Remove the optical drive and check for the correct seating of the brackets on the optical drive and in the top case. Reinstall drive in unit and retest. Verify if drive is still noisy.	Yes	Go to step 6.	
	No	Issue resolved. Optical drive was not properly mounted in enclosure. (Possible physical damage to optical drive.)	(J05)
6. Eject known good data CD. Disc handling noise should be one pop of disc from motor hub and a motor gear sound driving disc out of optical drive. Is noise above normal and related to disc eject activity or multiple eject attempts?	Yes	Replace optical drive.	J02
	No	Go to step 7.	
7. Disc spin should cease 30 seconds after mounting data CD on desktop. Media may be mounting on a defective internal spindle hub. Is the noise related to disc spin?	Yes	Replace optical drive.	J04
	No	Noise does not appear to be related to optical drive.	



Optical Drive Not Performing to Specs

Unlikely cause: LCD, speakers, fan, camera, microphone

Quick Check

Symptom	Quick Check
<p>Optical Drive Not Performing to Specs</p> <p>Read or write speeds slower than expected.</p>	<ol style="list-style-type: none"> 1. Test optical media in another drive of the same type in same type of computer to rule out media issue. 2. Check with known-good discs—Install discs that came with the computer. 3. For disc write issues, check with known-good media that performs well in another computer and drive of the same type. 4. Check both CD and DVD media. If only one type of media is producing errors, there might be a laser related issue. (J99)

Deep Dive

Check	Result	Action	Code
1. Can optical drive read both CD and DVD known-good media?	Yes	Go to step 5	
	No	Reading CD only or DVD only indicates laser issue, replace optical drive.	J03
		Optical drive cannot read any media reliably. Go to step 2.	
2. Reseat cable connections at logic board and optical drive. Verify that media is now recognized and reads reliably.	Yes	Reseat resolved issue.	X03
	No	Go to step 3.	
3. Disconnect optical drive by lifting SATA cable at logic board and connecting a known-good drive. Verify that media is now recognized and reads reliably.	Yes	SATA port functional, reconnect user's optical drive & SATA cable. Go to step 4.	
	No	Replace logic board.	M19



4. Install and test with replacement optical drive SATA flex cable. Verify that media is now recognized and reads reliably.	Yes	Cable change resolved issue.	X03
	No	Replace optical drive. (Mechanical damage to optical drive, if found)	J03 (J05)
5. Test write data to compatible CD and DVD media. Verify burned media is recognized and reads reliably.	Yes	Issue resolved.	
	No	Replace optical drive. (Mechanical damage to optical drive, if found)	J03 (J06)

Uncategorized Symptom

Quick Check

Symptom	Quick Check
Uncategorized Symptom Unable to locate appropriate symptom code	Verify whether existing symptom code applies to the issue reported by the user. If not, document reported symptom and send feedback to smfeedback@apple.com stating that a suitable symptom code could not be found.



Input/Output Devices

USB Port Does Not Recognize Known Devices

Unlikely cause: LCD, hard drive, optical drive

Quick Check

Symptom	Quick Check
USB Port Does Not Recognize Known Devices USB-wired keyboard/mouse or USB flash drive not recognized	<ol style="list-style-type: none"> 1. Check the for latest software update. 2. Use Apple System Profiler to verify the computer recognizes the USB bus. 3. Test port with known good Apple keyboard or mouse. 4. Verify any USB hubs have sufficient power.

Deep Dive

Check	Result	Action	Code
1. Reset SMC and clear PRAM. Was USB device recognized?	Yes	Issue resolved.	
	No	Go to step 2.	
2. Is USB device receiving power from USB port? Note: first device to need >500ma will get 1000ma, all others are limited to <500ma.	Yes	Go to step 3.	
	No	Replace logic board.	M15
3. Is the latest Mac-compatible USB software driver for this USB device installed?	Yes	Replace logic board.	M15
	No	Obtain Mac-compatible USB driver.	



Built-in Keyboard Does Not Work Properly

Unlikely cause: LCD, hard drive, optical drive

Quick Check

Symptom	Quick Check
Built-in Keyboard Does Not Work Properly <ul style="list-style-type: none"> Keystrokes not recognized Locks up Displayed characters don't match 	<ol style="list-style-type: none"> In System Preferences: International: Input Menu, enable Keyboard Viewer. Select Show Keyboard Viewer from the Input Menu in the menu bar. Test the keyboard. Confirm correct keyboard layout is selected. Update to the latest system software. Press Caps Lock, if the Caps Lock light goes on to show at least a partial connection to the main logic board.

Deep Dive

Check	Result	Action	Code
1. If specific keys are not working, confirm if they are physically broken.	Yes	Refer to “MacBook/ MacBook Pro: Black Keycap Replacement” (HT4002) or “MacBook: White Keycap Replacement” (HT4003) . If a keycap kit is available for this model, order kit and replace affected key(s). Go to step 4.	
	No	If a keycap kit is not available for this model, replace complete top case. Go to step 4.	K01
2. Reseat keyboard flex cable to logic board and verify that all keys are functional.	Yes	Issue resolved.	X99
	No	Go to step 3.	
3. Disconnect and verify that keyboard flex cable is in good condition (no delamination or torn cable end, no missing or cracked tracks).	Yes	Go to step 4.	
	No	Replace top case. Go to step 5.	K01



4. Reseat cable and check that flex cable end is fully inserted and aligned with connector on logic board, and that connector lock is closed. Verify that keyboard now functions properly. Reseat cable and verify with ASD that all keys are functional.	Yes	Issue resolved.	K01
	No	Replace top case. Go to step 5.	
5. Verify that all keys are functional using ASD.	Yes	Issue resolved.	K01
	No	Replace logic board.	M15

Specific Keys Don't Work

Unlikely cause: power adapter, battery, speakers, LCD, ODD/HDD, fan, microphone

Quick Check

Symptom	Quick Check
Specific Keys Don't Work <ul style="list-style-type: none"> • Keycap broken • Key switch broken • Sticky key • Key pressed not recognized 	<ol style="list-style-type: none"> 1. Determine if damage caused by user/technician environment, accidental damage, or abuse. 2. Inform user/technician the failures are not covered by Apple warranties. Refer to http://www.apple.com/legal/warranty 3. Inspect keycap to remove debris trapped under it. 4. If the keycap is loose, check if clasp is still intact and reattach it. 5. Refer to "MacBook/MacBook Pro: Black Keycap Replacement" (HT4002) or "MacBook: White Keycap Replacement" (HT4003). If a keycap kit is available for this model, order kit and replace affected key(s). If a kit is not available, replace complete top case (code K01).



Built-in Trackpad Does Not Work

Quick Check

Symptom	Quick Check
Built-in Trackpad Does Not Work <ul style="list-style-type: none"> Cursor does not move. Select button of trackpad inoperable Multiple touch features inoperable 	<ol style="list-style-type: none"> Check for environmental factors such as humidity, hand lotion or jewelry. Check if user is touching the trackpad simultaneously with both hands. Clean the trackpad surface (with the computer powered off) using a clean, dry, lint-free cloth. Make sure all software and firmware updates have been applied.

Deep Dive

Check	Result	Action	Code
1. Can you see the trackpad continuously listed on USB in Apple System Profiler?	Yes	Go to step 5.	
	No	Go to step 2.	
2. Does trackpad look damaged? Verify trackpad alignment is proper and click-depth set screw is at factory setting.	Yes	Replace trackpad according to symptom found. - No mouse/trackpad response - Trackpad cursor not tracking properly - Trackpad button issues Go to step 6.	K02 K12 K13
	No	Go to step 3.	
3. Reseat the trackpad flex cable to the logic board. Does trackpad work now?	Yes	Loose cable. Issue resolved.	
	No	Go to step 4.	
4. Is the trackpad connector on the logic board damaged?	Yes	Replace logic board.	M24
	No	Go to step 5.	



5. In System Preferences: Universal Access, turn off special Keyboard and Mouse & Trackpad settings. Set for normal use, enable and test multiple touch features. Does trackpad work now?	Yes	Settings issue resolved.	
	No	Go to step 6	
6. Does the select button click? Verify trackpad alignment is proper and click-depth set screw is at factory setting.	Yes	All trackpad issues resolved.	
	No	Go to step 7	
7. Does a known-good trackpad work?	Yes	Replace trackpad according to symptom found. - No mouse/trackpad response - Trackpad cursor not tracking properly - Trackpad button issues	K02 K12 K13
	No	Replace logic board.	M16



Built-in Keyboard Has Dim or No Keyboard Backlight

Unlikely cause: LCD, hard drive, optical drive

Quick Check

Symptom	Quick Check
Built-in Keyboard Has Dim or No Backlight <ul style="list-style-type: none"> In darkened room, keyboard backlight does not come on or is dim. 	<ol style="list-style-type: none"> Make sure this computer model has a keyboard backlight option by checking the configuration label in the battery bay. Make sure that keyboard backlight is turned on and brightness turned up. Block the ambient light sensor to simulate darkened room.

Deep Dive

Check	Result	Action	Code
1. Make sure the “illuminate keyboard in low light condition” option is checked in Keyboard System Preferences; then cover the ambient light sensor located on left of camera. Did the display dim?	Yes	Ambient light sensor is working. Go to step 4.	
	No	Go to step 2.	
2. Cover the ambient light sensor again. Did the keyboard backlight work?	Yes	Issue resolved.	
	No	Go to step 3.	
3. In the Apple System Profiler, can you see the AirPort and Bluetooth cards?	Yes	The light sensor connection to logic board is likely good. Replace display assembly.	L14
	No	Go to step 4.	
4. Reseat the keyboard backlight connection to the logic board. Does the keyboard backlight work now?	Yes	Issue resolved.	
	No	Go to step 5	
5. Measure the voltage between pin 4 and pin 2 of the keyboard backlight connector J5815. Is there voltage present with the running system in a dark room?	Yes	Replace top case.	K10
	No	Replace logic board.	M99

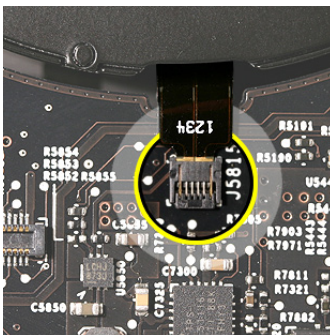



Built-in Keyboard Is Not Recognized

Unlikely cause: LCD, hard drive, optical drive

Quick Check

Symptom	Quick Check
Built-in Keyboard Is Not Recognized <ul style="list-style-type: none"> Keystrokes not recognized 	<ol style="list-style-type: none"> Reset SMC. Press Caps Lock. If the Caps Lock light comes on that indicates at least a partial connection to the logic board. In System Preferences: International: Input Menu, enable Keyboard Viewer. Select Show Keyboard Viewer from the Input Menu in the menu bar. Test the keyboard.

Deep Dive

Check	Result	Action	Code
1. In Apple System Profiler do you see "Apple Internal Keyboard/Trackpad" listed under USB hardware devices?	Yes	Go to step 3.	
	No	Go to step 2.	
2. Reset SMC and verify if keyboard/trackpad is now seen in Apple System Profiler.	Yes	Go to step 3.	
	No	Replace logic board.	M15
3. Disconnect and verify that keyboard flex cable is in good condition (no delamination or torn cable end, no missing or cracked tracks).	Yes	Go to step 4.	
	No	Replace top case. Go to step 5.	K11
4. Reseat cable and check that flex cable end is fully inserted and aligned with connector on logic board, and that connector lock is closed. Verify that keyboard now functions properly.	Yes	Issue resolved.	
	No	Replace top case. Go to step 5.	K11
5. Verify that all keys are functional using ASD.	Yes	Issue resolved.	
	No	Replace logic board.	M15



Built-in Trackpad Does Not Track Properly

Unlikely cause: LCD, hard drive, optical drive

Quick Check

Symptom	Quick Check
Built-in Trackpad Does Not Track Properly <ul style="list-style-type: none"> Cursor movement is random, uneven, or jumpy. Cursor hangs or stalls along path. 	<ol style="list-style-type: none"> Check for environmental factors such as humidity, hand lotion or jewelry. Check if user is touching the trackpad simultaneously with both hands. Clean the trackpad surface (with the computer off) using a clean, dry, lint free cloth. Make sure all software and firmware updates have been applied. If the issue occurs when system is running from the power adapter, use a grounded power cord with the power adapter.

Deep Dive

Check	Result	Action	Code
1. Can you see the trackpad continuously listed under USB in Apple System Profiler?	Yes	Trackpad communicating to system. Go to step 5.	
	No	Go to step 2	
2. Does the trackpad look damaged?	Yes	Replace trackpad. Go to step 6.	K02
	No	Go to step 3.	
3. Reseat the trackpad flex cable on the logic board. Does the trackpad work now?	Yes	Loose cable. Issue resolved.	
	No	Go to step 4.	
4. Is the trackpad connector on the logic board damaged?	Yes	Replace logic board.	M24
	No	Go to step 5.	
5. In System Preferences: Universal Access, turn off special Keyboard and Mouse & Trackpad settings. Does trackpad work now?	Yes	Settings issue resolved.	
	No	Go to step 6.	



6. Does a known-good trackpad work?	Yes	Replace trackpad according to symptom found. - No mouse/trackpad response - Trackpad cursor not tracking properly - Trackpad button issues.	K02 K12 K13
	No	Replace logic board.	M16

Apple Remote Inoperable

Unlikely cause: LCD, hard drive, optical drive

Quick Check

Symptom	Quick Check
Apple Remote Inoperable <ul style="list-style-type: none"> Remote is not recognized. 	<ol style="list-style-type: none"> The computer is on and awake. Check with known-good remote on user's computer and the user's remote on known-good computer Remote is used within 30 feet of the computer and unobstructed line-of-sight to the IR window. Clean the IR window. Open System Preferences: Security pane. Verify that "Disable remote control infrared receiver" is not checked. In Security pane, if "Unpair" button is active, press it and pair the Apple Remote. See "Pairing your Apple Remote with your computer" (Knowledge Base HT1619).



Deep Dive

Check	Result	Action	Code
1. Open Photo Booth or iChat's Video Preview window. Point Apple Remote at built-in iSight camera, press any button on remote, and verify that (as seen through the camera) a faint blinking light is on the remote.	Yes	Apple Remote works. Go to step 2.	
	No	Replace the remote's battery. Go to step 2.	
2. Verify that you can pair the Apple Remote with a known-good system?	Yes	Go to step 3.	
	No	Replace the Apple Remote. Go to step 3.	X04
3. Verify that Apple Remote now works.	Yes	Issue resolved.	
	No	Check and reseal IR/sleep LED board cable connection at logic board. Go to step 4.	
4. Does the Apple Remote now work?	Yes	Issue resolved.	
	No	Replace the hard drive front bracket (includes IR/sleep cable). Go to step 5.	
5. Does the Apple Remote now work?	Yes	Issue resolved.	K99
	No	Replace logic board.	M15

Built-in Speaker Has No Audio

Unlikely cause: LCD, hard drive, optical drive

Quick Check

Symptom	Quick Check
Built-in Speaker Has No Audio Can't hear any audio from within the machine.	<ol style="list-style-type: none"> 1. Make sure all software updates have been applied. 2. Check in System Preferences: Sound: Output that sound output is set to "Internal Speakers." 3. Use the F12 volume key to set the sound to maximum. 4. Reset PRAM.



Deep Dive

Check	Result	Action	Code
1. Check System Preferences: Sound: Output and verify that no external speakers, "Digital Out," or headphones are being reported connected when there is none present.	Yes	Audio-out port is not damaged. Go to step 3.	
	No	Go to step 2	
2. With known-good headphone or speakers, plug in the audio output jack for several cycles. Verify that you get audio through external headphones/speakers when connected.	Yes	Go to step 4	
	No	Reseat the speaker connectors to logic board. Go to step 3.	
3. Verify that you now get audio through internal speakers .	Yes	Issue resolved.	
	No	Replace logic board.	M09
4. Disconnect known-good headphones or speakers. Verify that you now get audio through internal speakers.	Yes	Issue resolved.	
	No	Replace affected speaker(s).	X08

Distorted Sound from Internal Speaker

Unlikely cause: LCD, hard drive, optical drive

Quick Check

Symptom	Quick Check
Distorted Sound from Internal Speaker <ul style="list-style-type: none"> Distorted audio 	<ol style="list-style-type: none"> Reset PRAM. Adjust sound output and level in System Preferences: Sound: Output, and use the Balance to locate a left, right, or woofer speaker distortion source. Compare the same sound and same settings against another unit to make sure the sound is actually distorting.



Deep Dive

Check	Result	Action	Code
1. Comparing internal speakers with headphones, is the distortion on both headphones and speakers?	Yes	Audio source or gain issue. Reset PRAM, adjust sound level in System Preferences: Sound: Output, and retest with known-good audio source and external speakers. Go to step 5.	
	No	Internal speaker issue. Go to step 2.	
2. Use the Sound Output system preference to test the left and right speakers. If lower bass notes are distorted, right speaker/subwoofer may be defective. Are all speakers free of distortion, sounding clear and loud?.	Yes	Issue resolved.	
	No	Adjust volume to test full range of volume settings. Go to step 3.	
3. Is affected speaker cable properly inserted and free from damage?	Yes	Go to step 4.	
	No	Reseat speaker cable or replace damaged speaker. Go to step 5.	X09
4. Is affected speaker membrane free from dust or debris, and speaker membrane is not deformed/damaged?	Yes	Go to step 5.	
	No	Clean any dust or debris. Go to step 5. If membrane is damaged, replace the bad speaker(s).	X09
5. Verify that speaker enclosure is not damaged, correctly installed in system, and does not create unneeded vibration when sound is played.	Yes	Speaker housing and installation is good. Go to step 6.	
	No	Properly install or replace affected speaker. Go to step 6.	
6. Verify that internal speakers no longer produce distorted sound.	Yes	Issue resolved.	X09
	No	Replace logic board.	M09



Express Card Will Not Insert Into Slot

Unlikely cause: LCD, MLB, hard drive

Quick Check

Symptom	Quick Check
<p>ExpressCard will not insert into ExpressCard Slot</p> <p>ExpressCard does not fully seat into the slot</p> <p>Slot door does not open completely</p>	<ol style="list-style-type: none"> 1. The card must be a 34mm wide card with the top side oriented up and not be warped or damaged. 2. Clear any obstruction in the slot.

Deep Dive

Check	Result	Action	Code
1. Is the slot cover opening properly?	Yes	.Go to step 3	
	No	Re-seat the ExpressCard Cage and inspect the slot cover. Go to step 2.	
2. Does the slot cover open properly after the adjustments?	Yes	Issue resolved.	
	No	Replace top case.	X13
3. Can the ExpressCard slide completely into the slot?	Yes	Issue resolved.	
	No	Re-seat the ExpressCard Cage with the card already installed in the card cage.. Go to step 4.	
4. Ejecting the ExpressCard and re-inserting it, does it completely slide into the slot?	Yes	Issue resolved.	X13
	No	Replace the ExpressCard Cage.	M17



Express Card Not Recognized By System

Unlikely cause: LCD, MLB, HDD/ODD

Quick Check

Symptom	Quick Check
<p>ExpressCard is not recognized by the system.</p> <p>Card does not show up on the desktop or in System Profiler</p>	<ol style="list-style-type: none"> 1. Check correct drivers are installed for the ExpressCard. 2. Verify with known good USB and PCI Express based ExpressCards that the slot is good.

Deep Dive

Check	Result	Action	CSC
1. Does the ExpressCard cable connection to the main logic board look secure?	Yes	Go to step 3	
	No	Re-seat the ExpressCard Cage cable connection. Go to step 2.	
2. Is the card recognized?	Yes	Bad connection. Issue resolved.	X04
	No	Go to step 3	
3. Does the ExpressCard cage look damaged (connector or cage)?	Yes	Replace the ExpressCard cage. Go to step 5	
	No	Remove the ExpressCard cage, install an ExpressCard (one fits completely inside), then re-installed the card cage. Go to step 4.	
4. Is the card recognized?	Yes	Card cage mounting issue. Issue resolved.	X99
	No	Replace the ExpressCard cage. Go to step 5	X13
5. Is the card recognized?	Yes	Bad ExpressCard cage. Issue resolved.	X13
	No	Replace the logic board.	M17



FireWire Port Not Recognizing Known Devices

Unlikely cause: LCD,HDD/ODD

Quick Check

Symptom	Quick Check
FireWire Port is not recognizing known devices Attached FireWire device like digital camera or mass storage drive not recognized by the system	<ol style="list-style-type: none"> 1. Check for latest software update. 2. Use Apple System Profiler to verify the computer recognizes the FireWire bus. 3. Test port by connecting to another computer using FireWire Target Disk Mode. 4. Verify the FireWire cable is good. 5. Verify a self powered FireWire device is getting power

Deep Dive

Check	Result	Action	Code
After resetting SMC, was the FireWire Port recognized?	Yes	Issue resolved.	
	No	FireWire port is bad. Replace main logic board.	M12

Uncategorized Symptom

Quick Check

Symptom	Quick Check
Uncategorized Symptom Unable to locate appropriate symptom code	Verify whether existing symptom code applies to the issue reported by the customer. If not, document reported symptom and send feedback to smfeedback@apple stating that a suitable symptom code could not be found.



Mechanical Issues: Thermals and Enclosure

Reset/Power Button Stuck

Unlikely cause: LCD, hard drive, optical drive

Quick Check

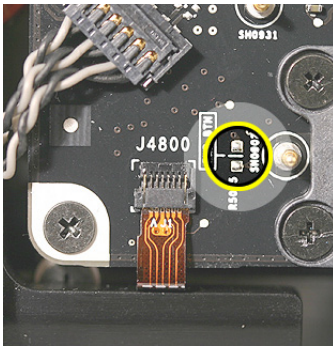

Symptom	Quick Check
Reset/Power Button Stuck <ul style="list-style-type: none"> System will not power on System sounds bootROM unlock tone during startup System automatically starts up repeatedly 	<ol style="list-style-type: none"> Diagnose stuck button with SMC keyboard reset sequence Inspect keyboard connection to logic board. Try logic board power-on pads to determine open or closed power-on key. Closed circuit will not allow on-board switch to work. If stuck down or closed, remove keyboard cable from logic board and try on board switch again to determine if top case is defective. If logic board will not power on with keyboard cable removed, troubleshoot no power/no boot.

Deep Dive

Check	Result	Action	Code
1. Reset SMC using keyboard 3 keys and power-on key. MagSafe LED can verify SMC reset. Momentary stop of battery charging will indicate SMC reset, orange LED will go green momentarily then return to orange.	Yes	Keyboard reset works while holding 3 keys and toggling power-on key, multiple press and release of power-on key works to show power-on key not stuck or fixed.	
	No	SMC keyboard reset not working, suggests power-on key is open circuit or stuck down. Go to step 2.	
2. Remove battery and AC power for 30 seconds to perform a manual SMC reset. Apply AC power. Does power-on key work when pressed?	Yes	SMC restored from power removal sequence. Power-on key now working properly.	
	No	Power-on key stuck or open. Go to step 3.	



3. Inspect keyboard flex cable for loose or damaged connections. Align and reseat to flex cable to ensure proper connections. Does power-on key now work correctly?	Yes	Cable reseat restored power-on key operation.	
	No	Power-on key still stuck or open. Go to step 4.	
4. Use conductive tool to assert power on by touching power-on switch pads on logic board.	Yes	System powers on suggests top case power on key circuit is open. Replace top case.	X14
	No	Power-on key circuit may be closed suggesting a stuck power-on key. Go to step 5.	
5. Disconnect the internal keyboard flex cable and assert power-on switch pads on logic board. Removing top case power-on key from circuit should free on-board switch to work properly.	Yes	On board power-on switch pads now starts the system. Replace top case due to stuck power-on key.	X14
	No	Go to M01: No power/ not booting	

System Runs Hot

Unlikely cause: LCD, hard drive, optical drive

Quick Check

Symptom	Quick Check
System Runs Hot <ul style="list-style-type: none"> System feels very warm Fan(s) not working Fan(s) are full on 	<ol style="list-style-type: none"> Verify the computer operating on a flat, hard surface and the vents are not blocked. Verify the computer is not running hotter than expected for normal operation. If possible, compare to a similarly configured computer. Reset SMC. Inspect fan performance Run thermal sensor test.

Deep Dive

Check	Result	Action	Code
-------	--------	--------	------



1. Is the system running as expected (compared to similar system)?	Yes	Use "Apple Portables: Operating Temperature" (Knowledge Base HT1778) to inform user it is operating normally.	
	No	Go to step 2.	
2. Are there runaway applications? See "Runaway applications can shorten battery run time" (Knowledge Base TS1473).	Yes	Check with the vendor for compatibility and software update.	
	No	Go to step 3.	
3. Fans are typically on at minimum speed. Perform SMC reset or remove all power for 15 minutes. Is the fan(s) running properly?	Yes	Go to step 5.	
	No	Fan(s) not running or always running at full speed. Go to step 4.	
4. Reseat fan connection to logic board or test a known-good fan. Replace a fan that is not spinning or replace logic board that is not spinning a known-good fan. Is fan(s) working properly?	Yes	Reseating or replacing bad fan resolved issue. Replace logic board if it does not work with known-good fan.	X99 or M18
	No	Go to step 5.	
5. Is the heatsink installed properly with no damage to heat fins?	Yes	Go to step 7.	
	No	Replace missing screws or damaged heatsink. Go to step 6.	
6. Is the system running as expected?	Yes	Heatsink installed incorrectly. Issue resolved.	X10
	No	Go to step 7.	
7. Heatsink thermal grease possibly missing or improperly installed during previous repair?	Yes	Replace heatsink or install thermal grease.	X10
	No	Go to step 8.	
8. Inspect and reseat connections to thermal sensors throughout the system, run test for sensor monitoring.	Yes	Thermal module or other sensor reseat resolved issue.	X99
	No	Replace logic board if sensor error. Go to step 9.	



9. After logic board replacement, is the computer running as expected?	Yes	Bad logic board. Issue resolved.	M23
	No	Use minimum configuration troubleshooting to isolate the issue.	

Uncategorized Symptom

Quick Check

Symptom	Quick Check
Uncategorized Symptom Unable to locate appropriate symptom code	Verify whether existing symptom code applies to the issue reported by the user. If not, document reported symptom and send feedback to smfeedback@apple.com stating that a suitable symptom code could not be found.

 **Apple Technician Guide**

Take Apart

MacBook Pro (15-inch, Late 2008)



General Information

Connector Types on Logic Board

On the logic board are six types of connectors, each requiring special handling. Make sure you read these tips before disconnecting and installing the connectors.

Vertical Insertion (JST)

- Use black stick under cable to remove.
- Keep connector level to board when disconnecting and reconnecting.
- Press evenly when reconnecting or connector can be tipped up and not fully seated.

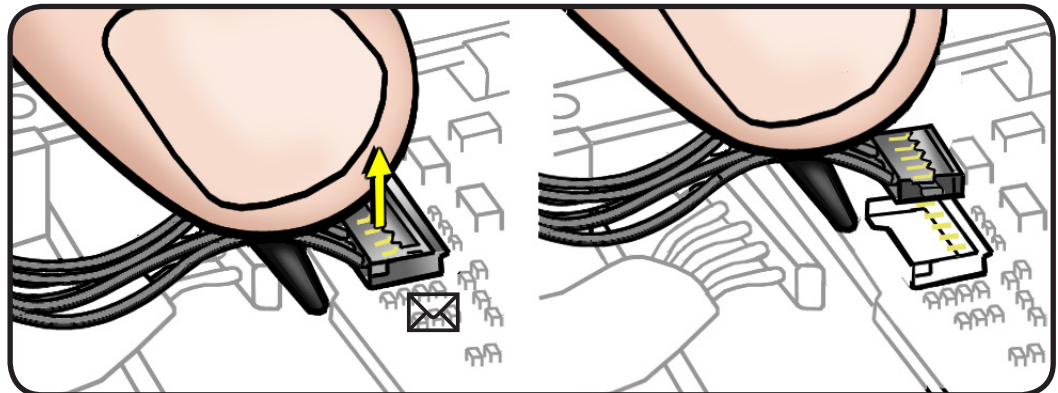

Examples:

- fan cable
- heatsink sensor
- left speaker on underside of board

Locking Lever

- Flip up lever 90 degrees for cable removal.
- Slide connector into receptacle. Use tweezers if necessary.
- Lock down lever after inserting cable.

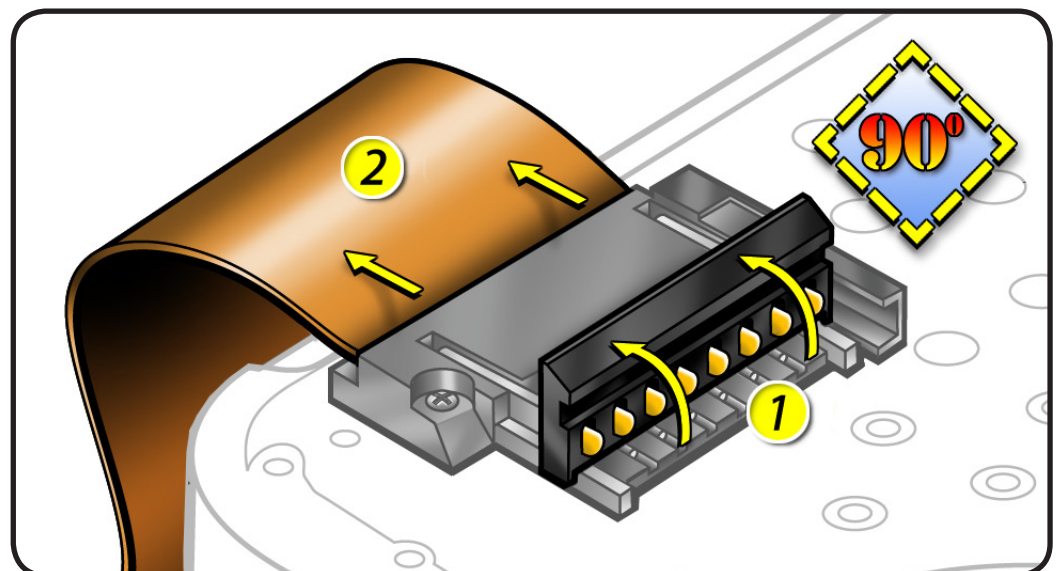

Examples:

- IR/SIL flex cable
- keyboard flex
- backlight flex cable



Horizontal Install

- Pull connector, not cable, to remove.
- Slide connector into receptacle on same horizontal plane as board.

Examples:

- MagSafe cable on underside of board
- battery power cable on underside of board

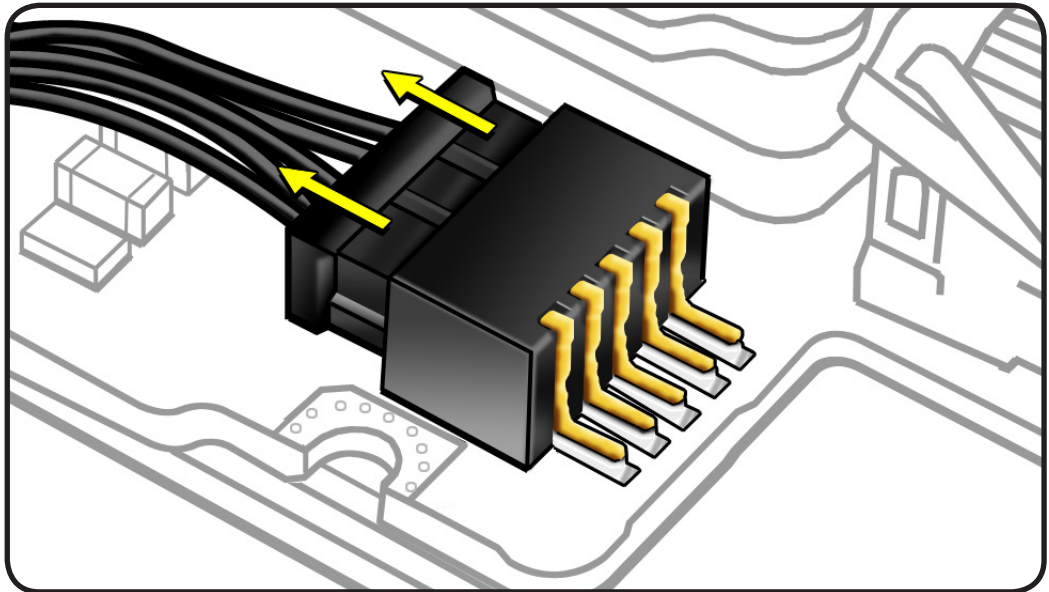

Thin, Multi-Pin Horizontal Insert

- Use fingernails or tweezers to remove evenly.
- Slide connector into receptacle on same horizontal plane as board.

Examples shown:

- LVDS cable with lock bar
- Camera/USB/AirPort/Bluetooth display cable

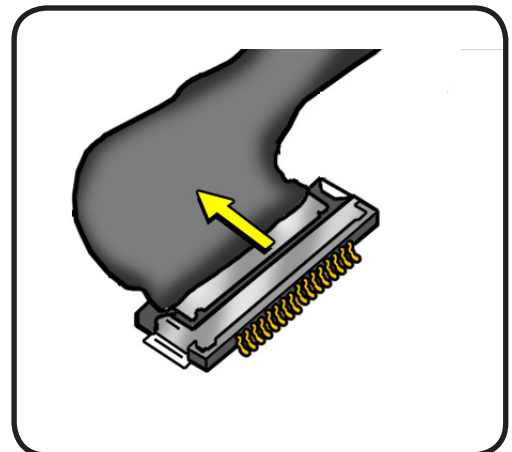
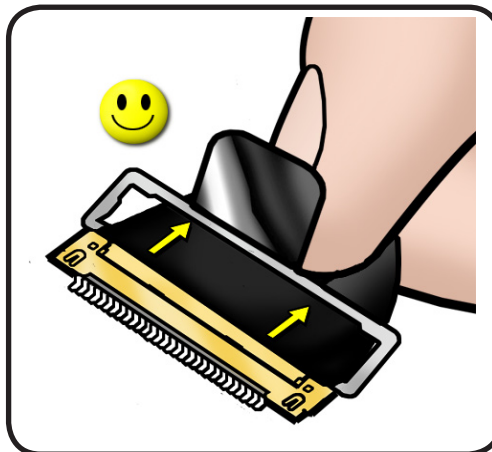



Replacement Caution:

When connecting cables, make sure they are fully connected.

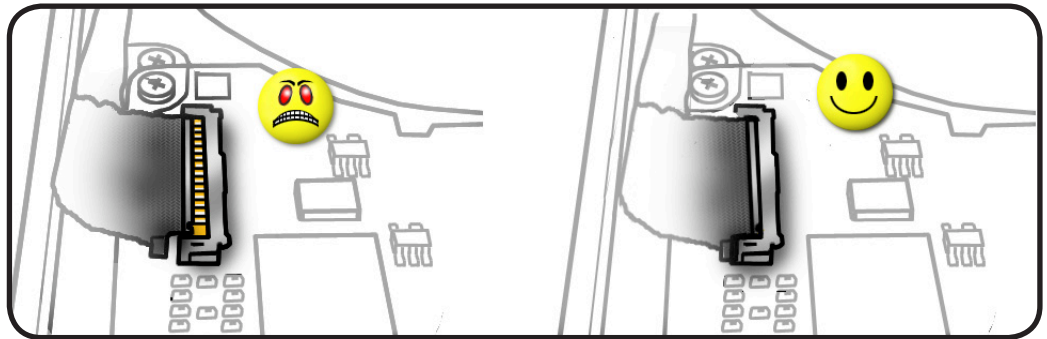

Replacement Caution: To avoid a short to the logic board, be sure to place EMI gasket on camera cable—positioned precisely where shown—**after** cable is fully connected to logic board. Then, place black shim behind connector.

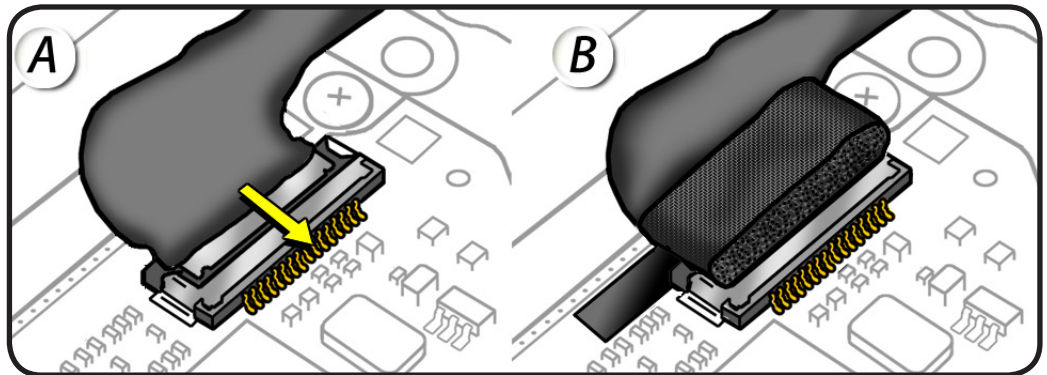

Low-Profile Solid Platform Flex

- Use black stick and gentle rocking motion to release tension to remove cable.
- Keep connector level to board and press evenly on platform to install.

Examples:

- optical drive flex cable
- trackpad flex cable

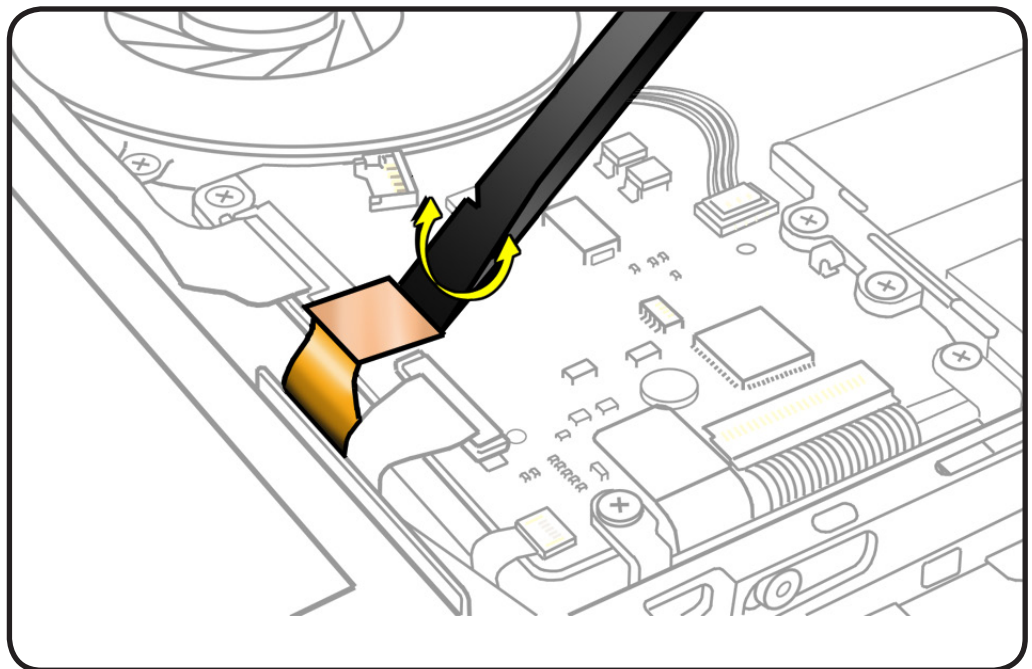



Access Door

First Steps:



Warning:

- Shut down computer.
- Unplug all cables.
- Put on ESD strap.

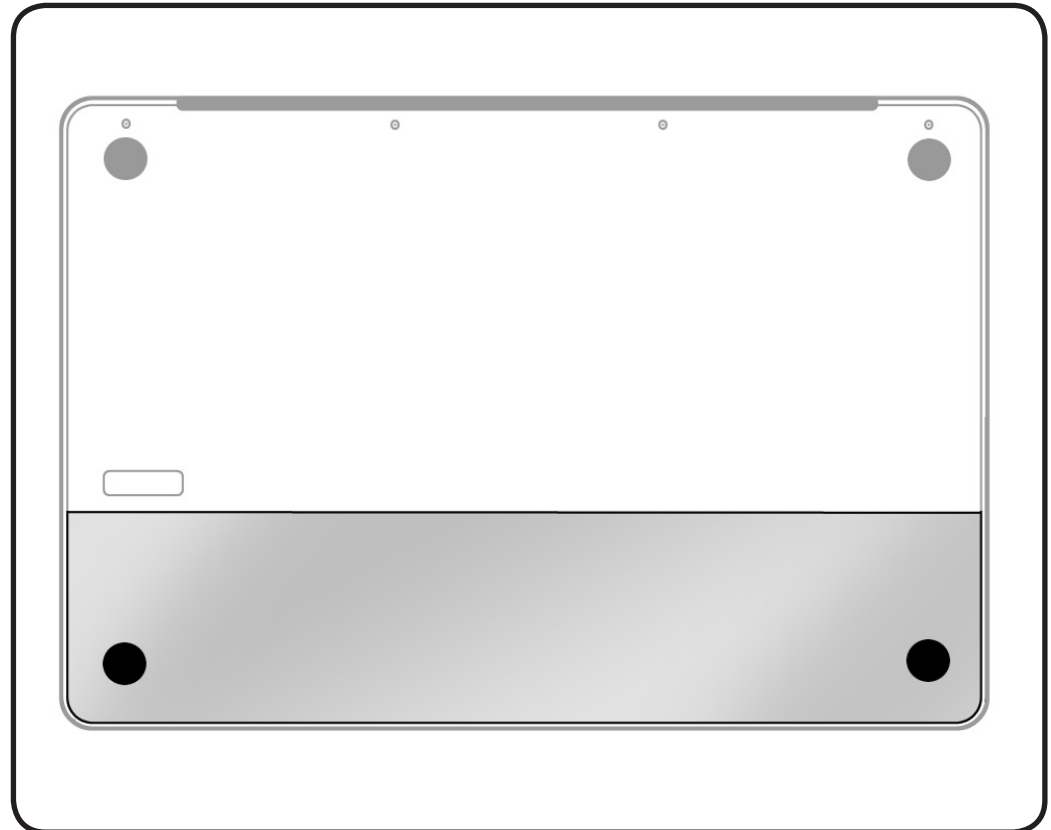

Tools

- Clean, soft, lint-free cloth
- ESD wrist strap and mat

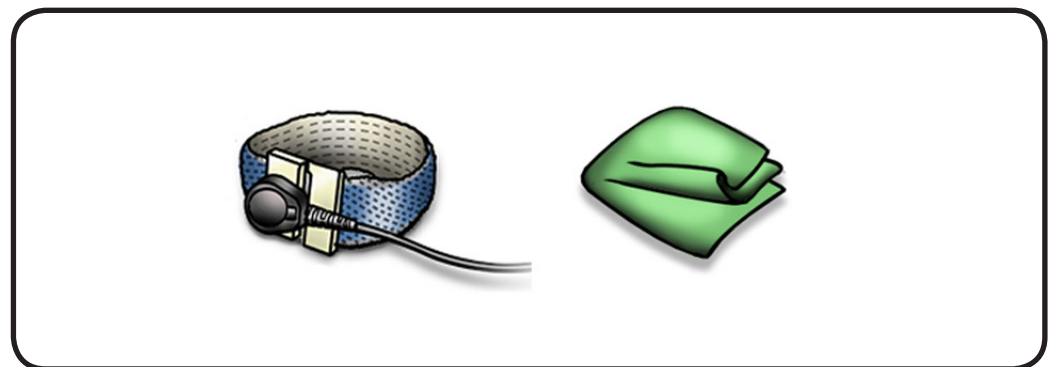



Removal

1 Press locking lever.

2 Lift off access door.

Replacement Note:
Align corners and tabs on access door with computer housing.

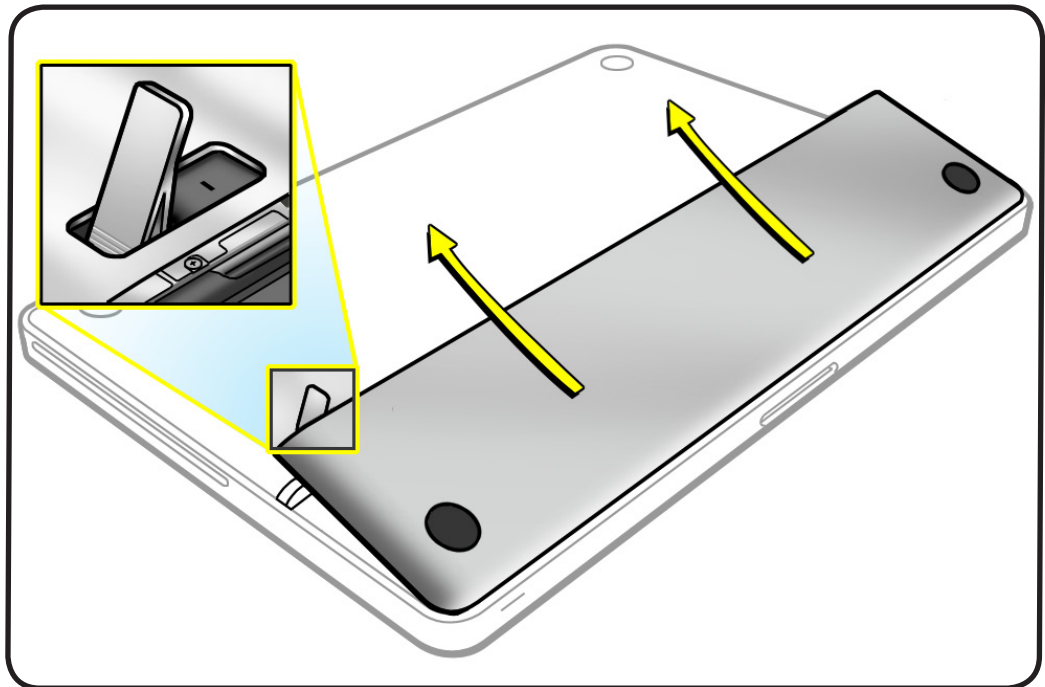



Battery

First Steps

Remove:

- [Access door](#)

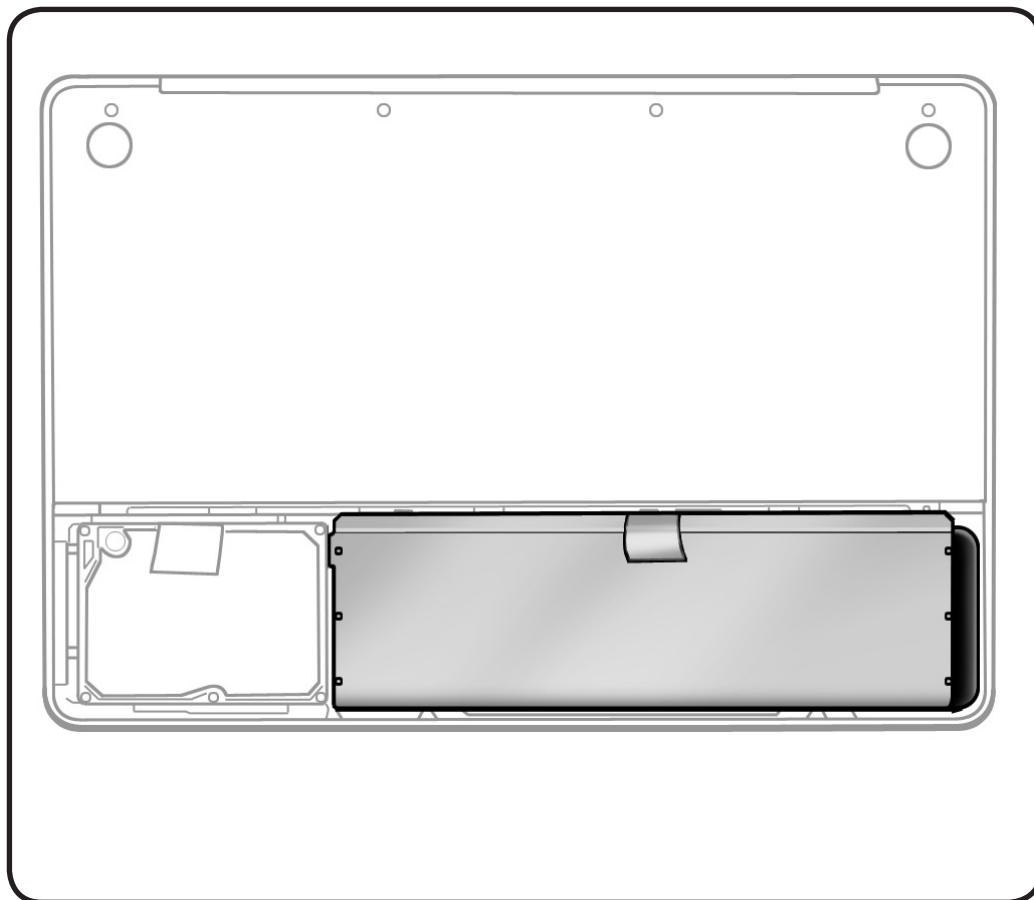

Tools

- Clean, soft, lint-free cloth
- ESD wrist strap and mat

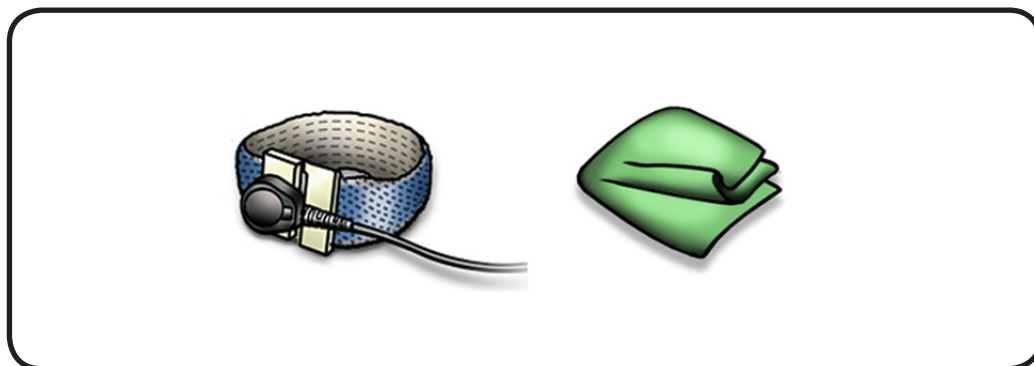



Removal

- 1 Make sure locking lever is up.

Pull battery tab to remove battery

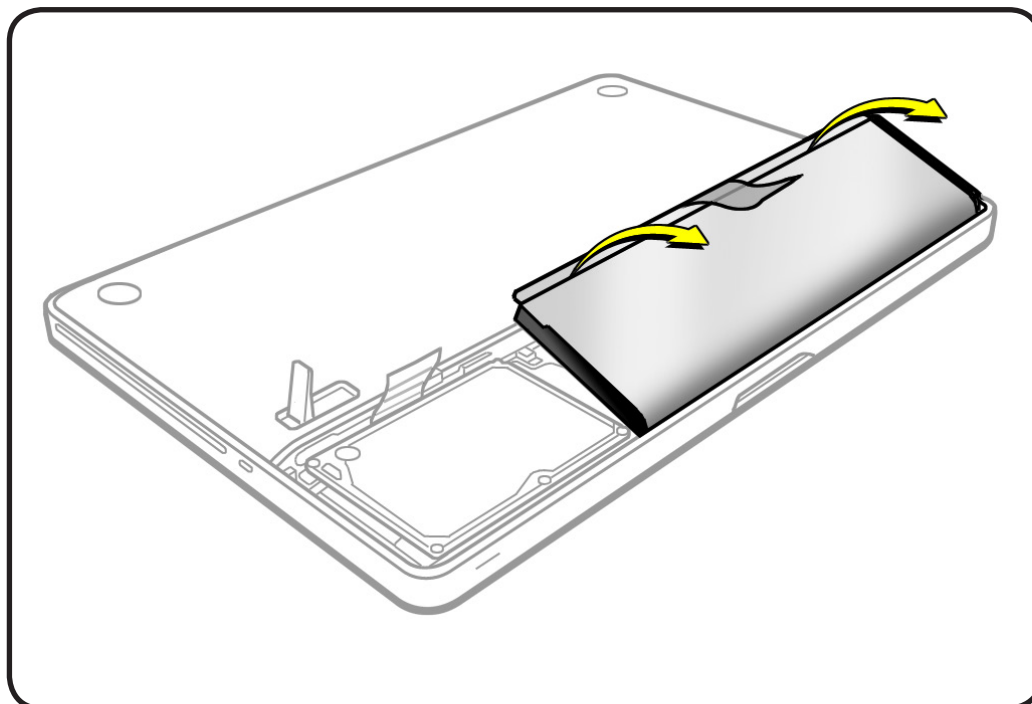

Replacement

- 1 Insert beveled edge of battery into battery bay.
 - 2 Reassemble computer.
- Note:** Make sure the battery connector is well seated.

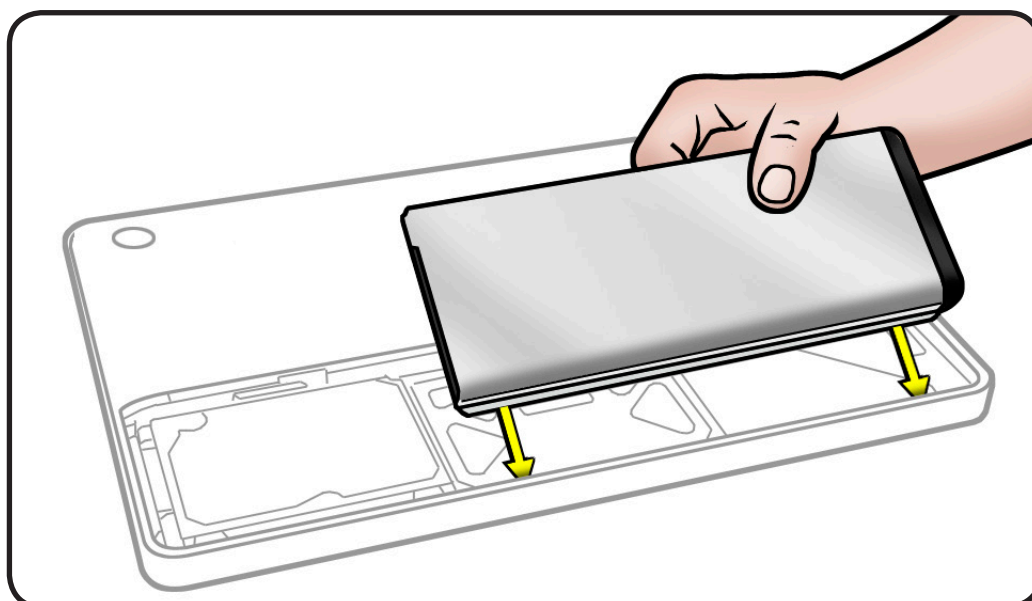



- 3** Press battery indicator light button to check charge level.

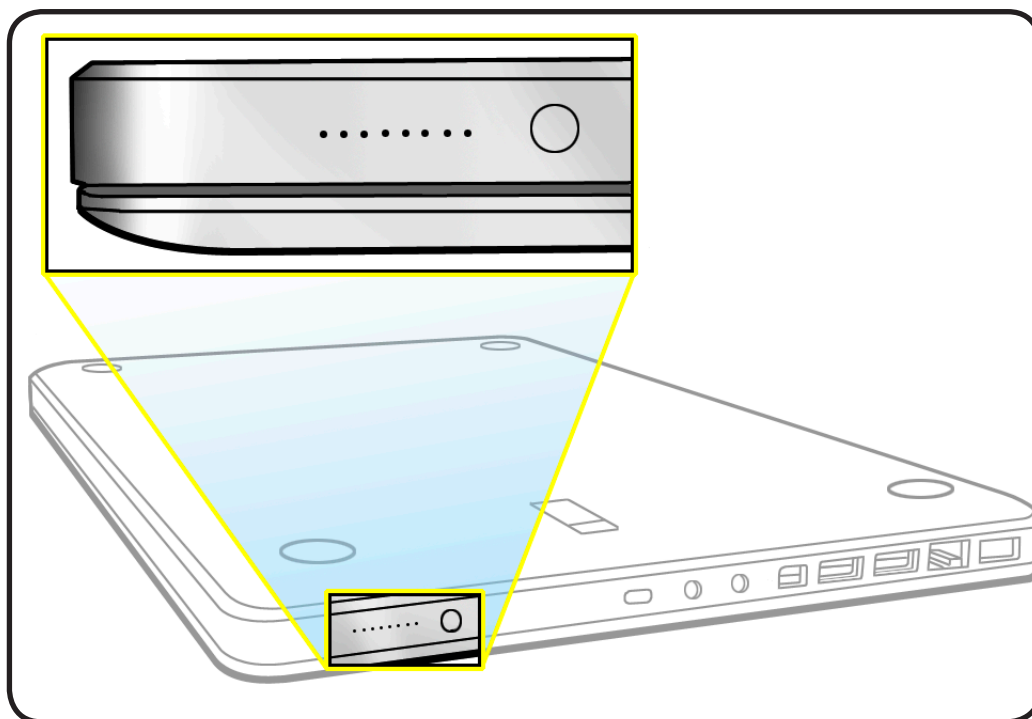



Hard Drive Bracket

First Steps

Remove:

- [Access door](#)
- [Battery](#)



Caution: Make sure data is backed up before removing the hard drive.

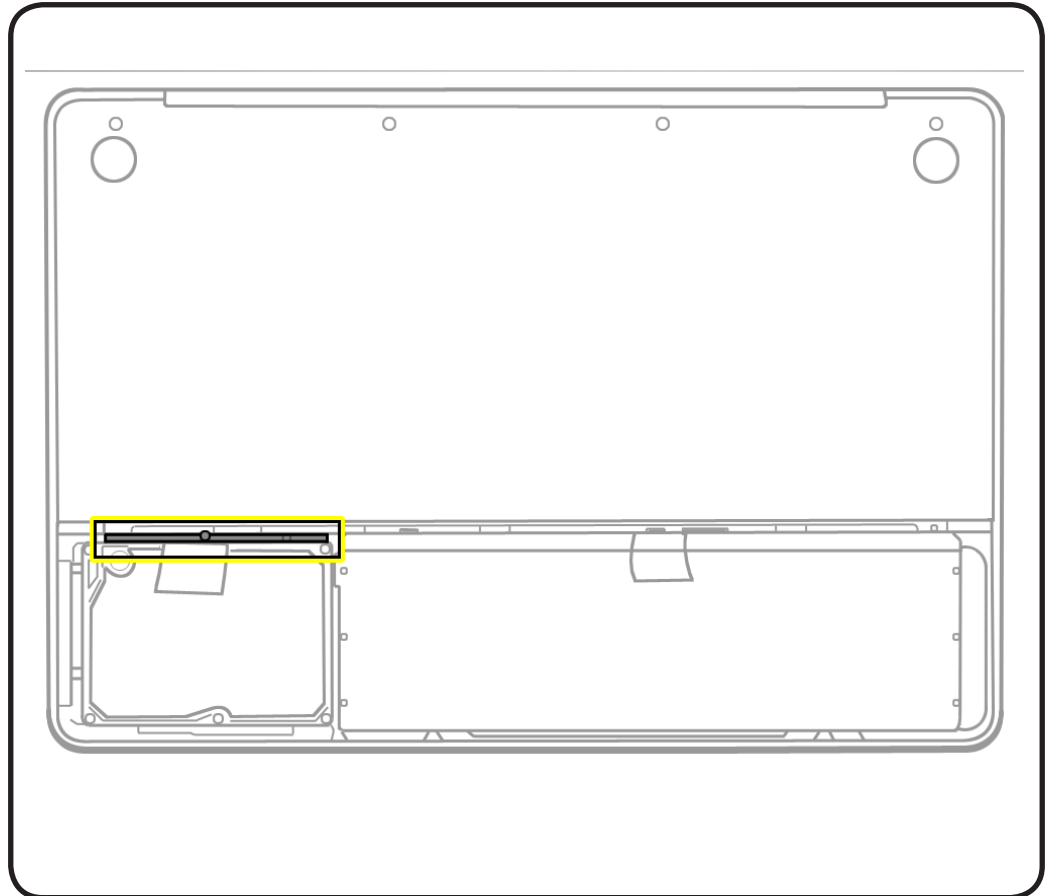

Tools

- Clean, soft, lint-free cloth
- ESD wrist strap and mat
- Magnetized Phillips #00 screwdriver

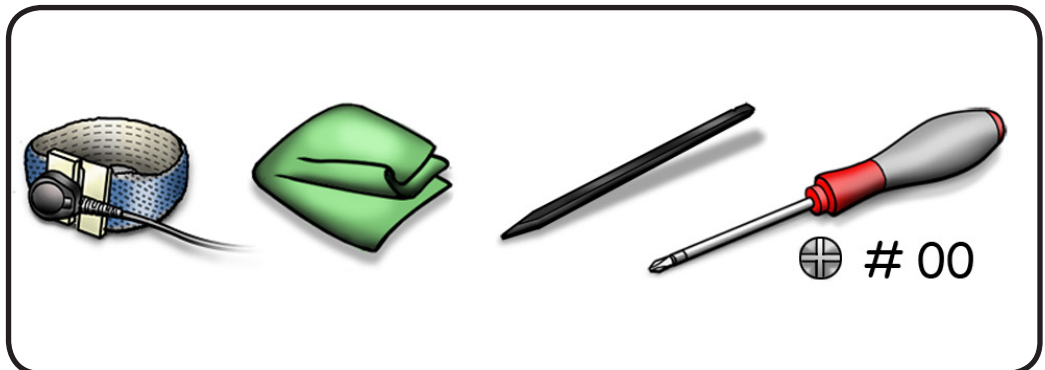



Removal

- 1 Loosen 1 captive screw.

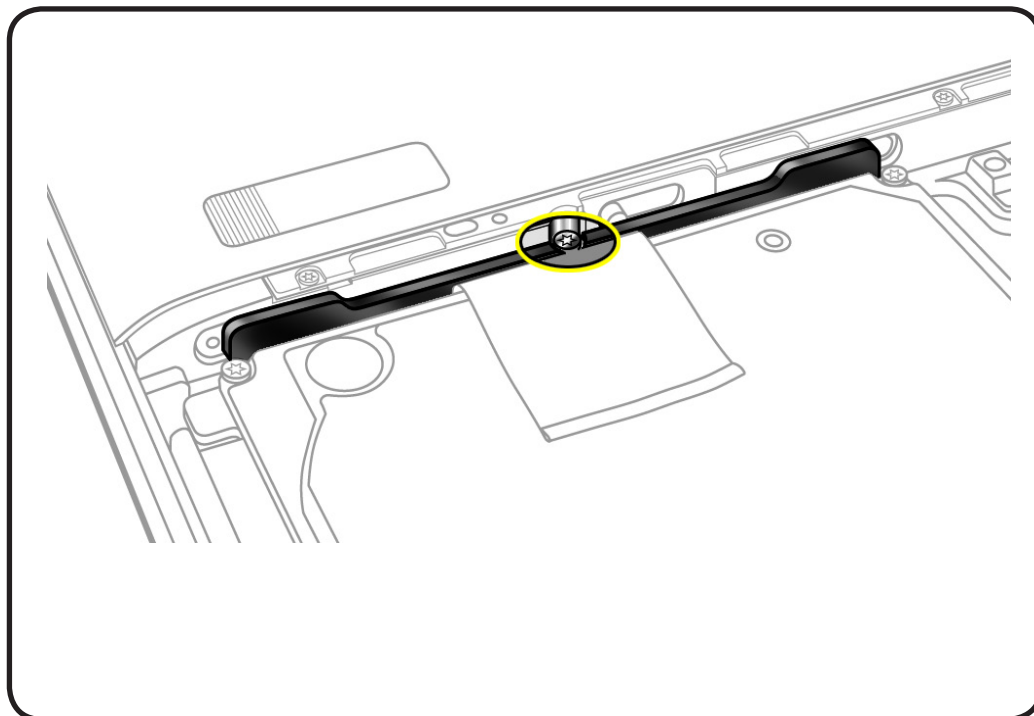

- 2 Lift out hard drive bracket.

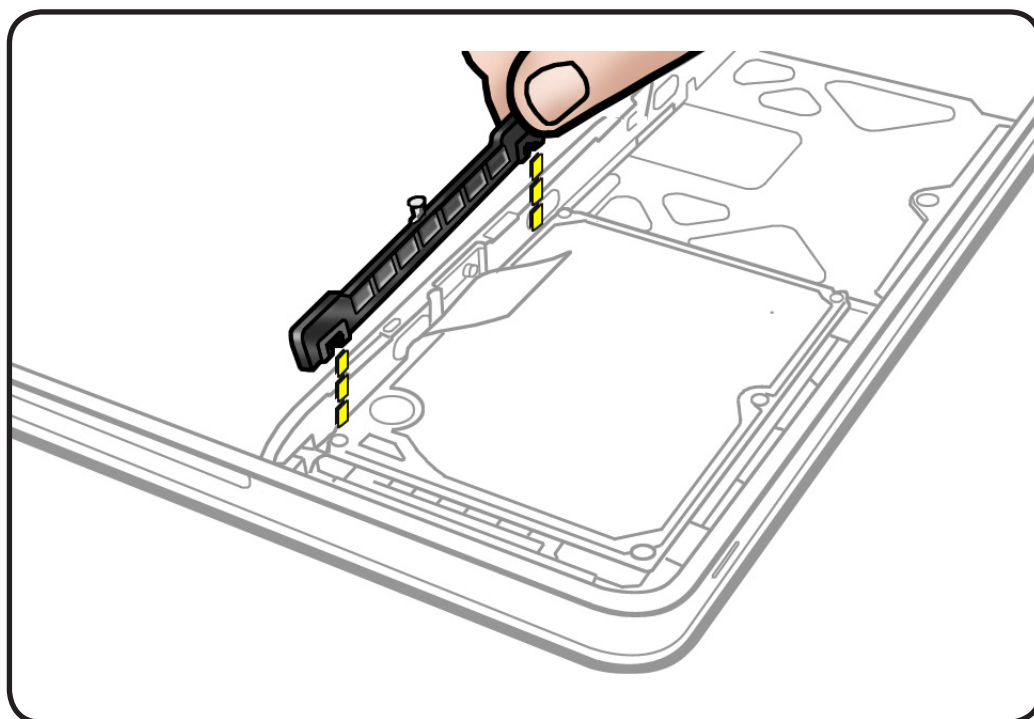



Replacement

- 1 Make sure 2 rubber grommets are included in hard drive bracket before installing it.

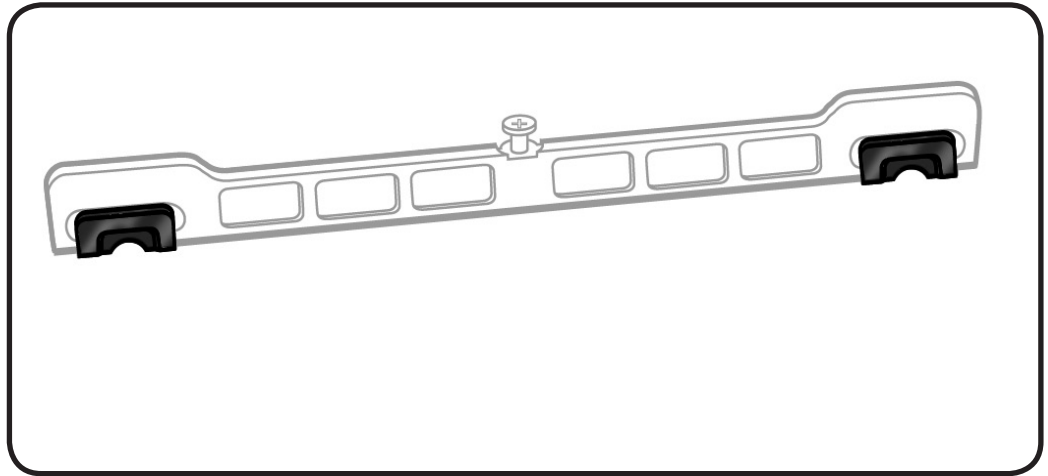

Hard Drive

First Steps

Remove:

- [Access door](#)
- [Battery](#)
- [Hard drive bracket](#)



Caution: Make sure data is backed up before removing the hard drive.

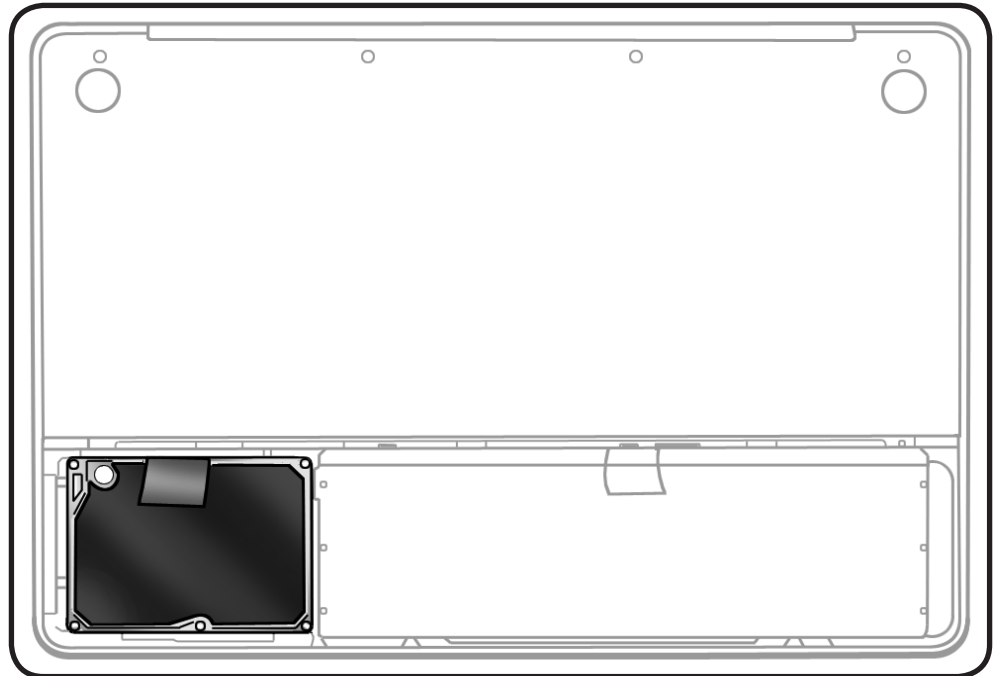

Tools

- Clean, soft, lint-free cloth
- ESD wrist strap and mat
- Magnetized Phillips #00 screwdriver

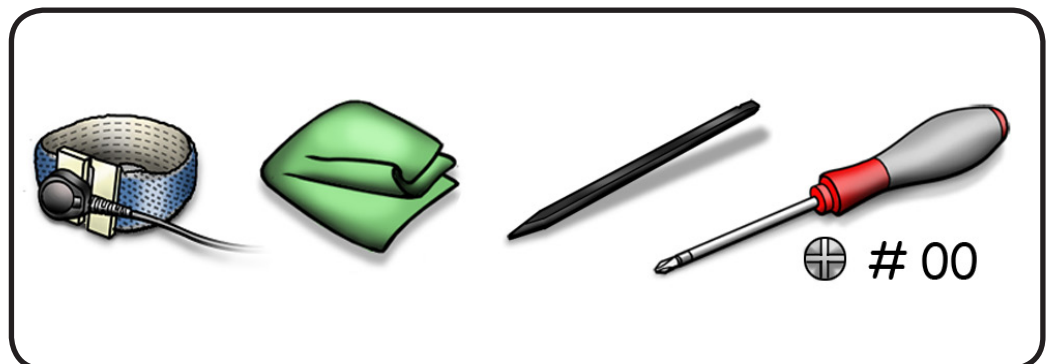

Removal

- 1 Make sure hard drive bracket is removed.

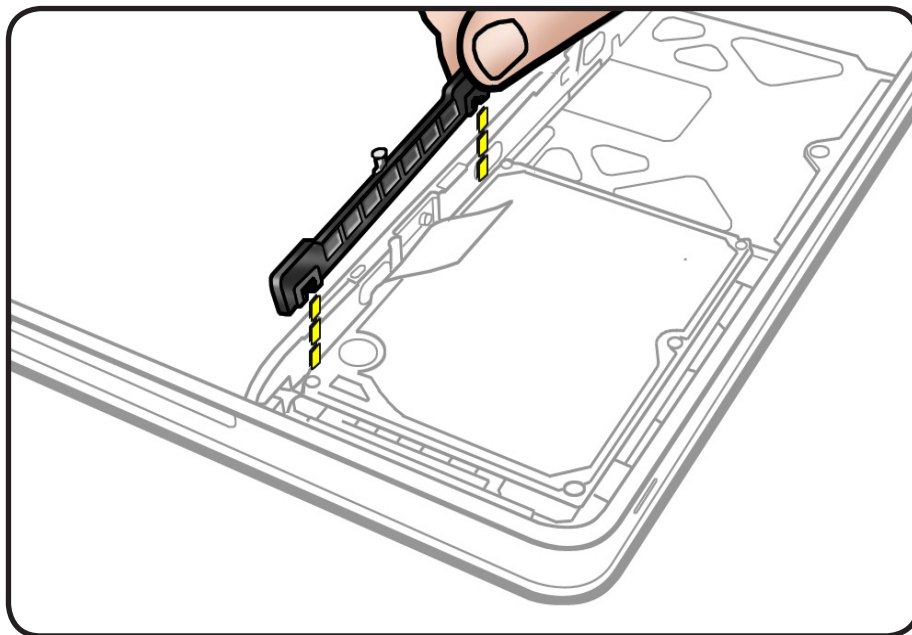

- 2 Use pull tab to tilt hard drive out.

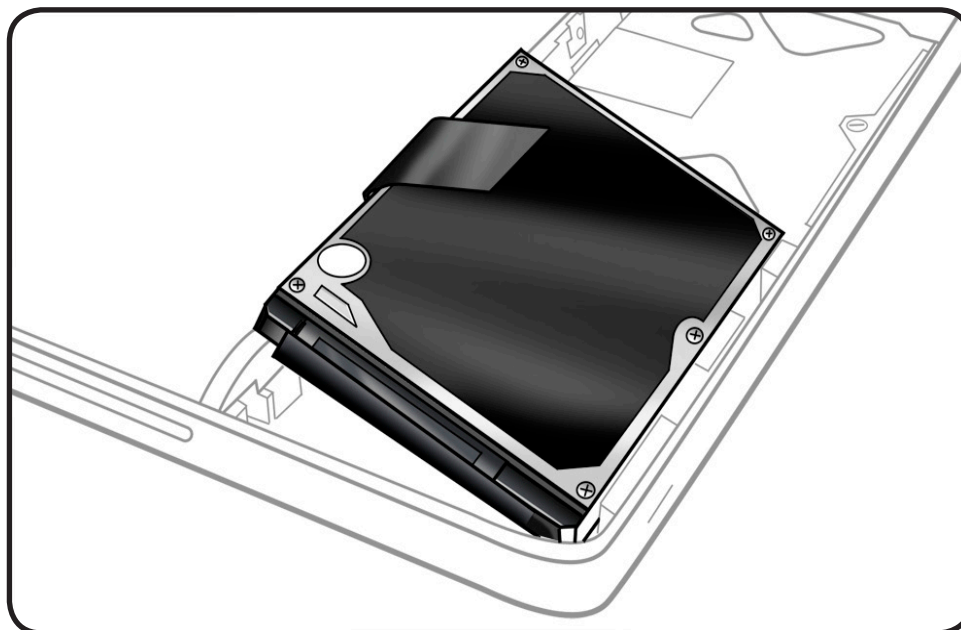

3 Hold hard drive by the sides only.

4 Disconnect hard drive connector.

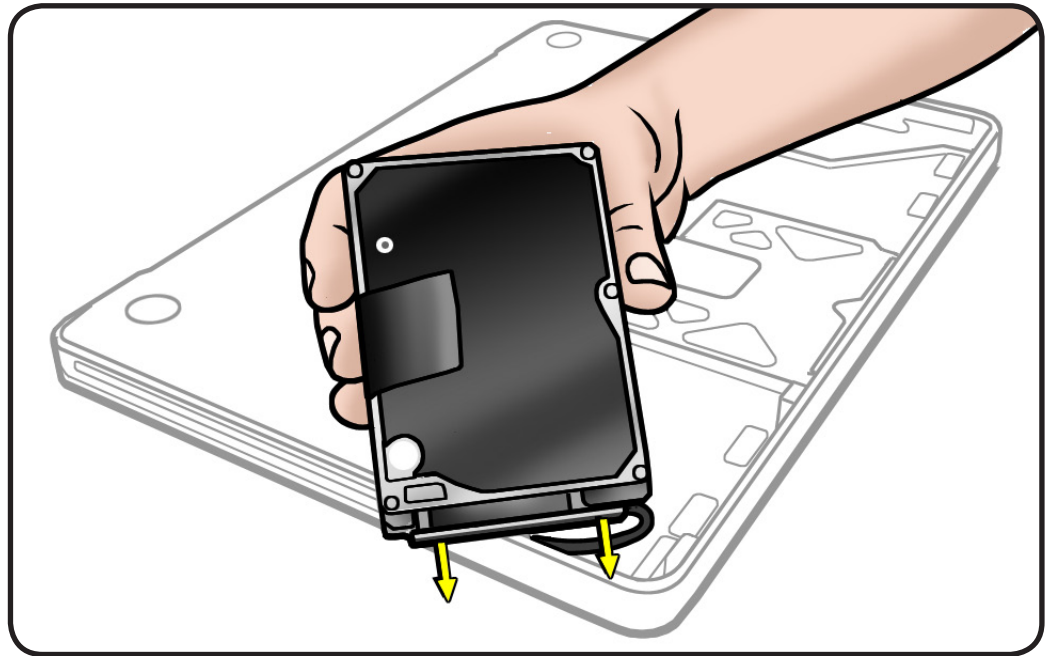

5 Follow safe handling:

- Do not press drive



- Do not touch connector

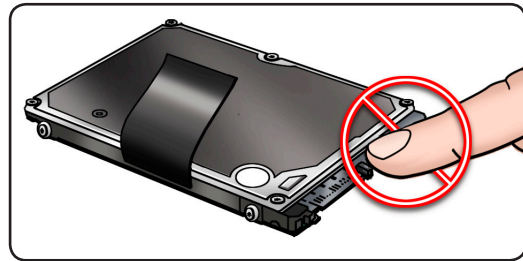

- Do not touch circuitry

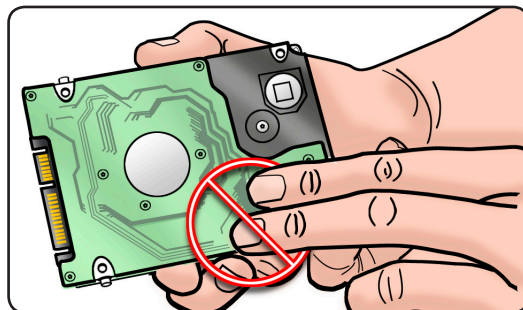

Replacement

- 1 Make sure 4 rubber grommets are seated in top case before installing the hard drive.

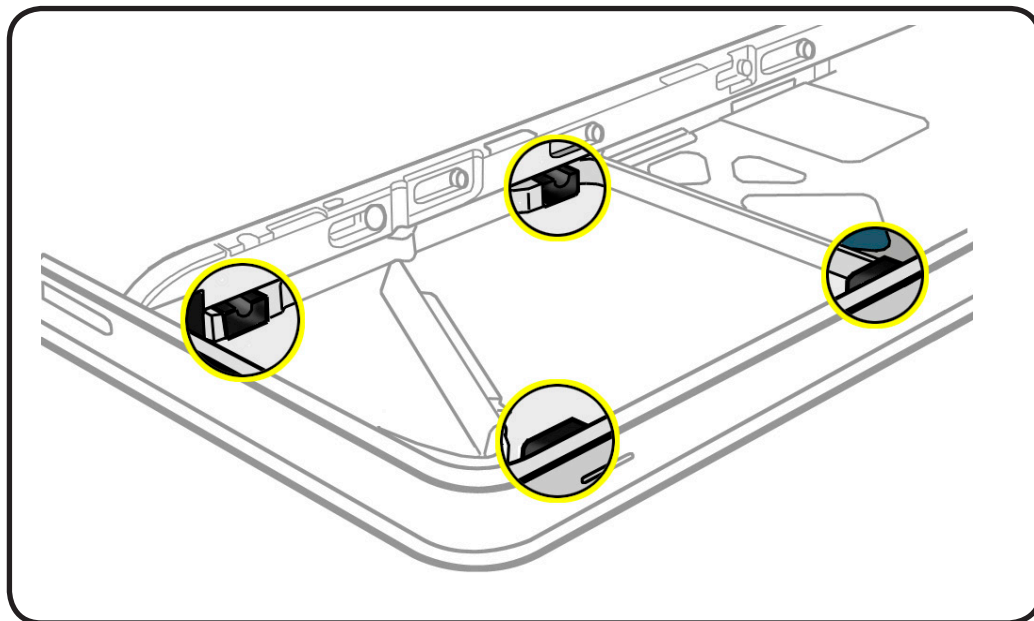

- 2 Make sure 4 Torx T6 mounting screws (922-8655) are installed on the drive.

If your replacement drive does not have mounting screws, transfer them from the old drive.

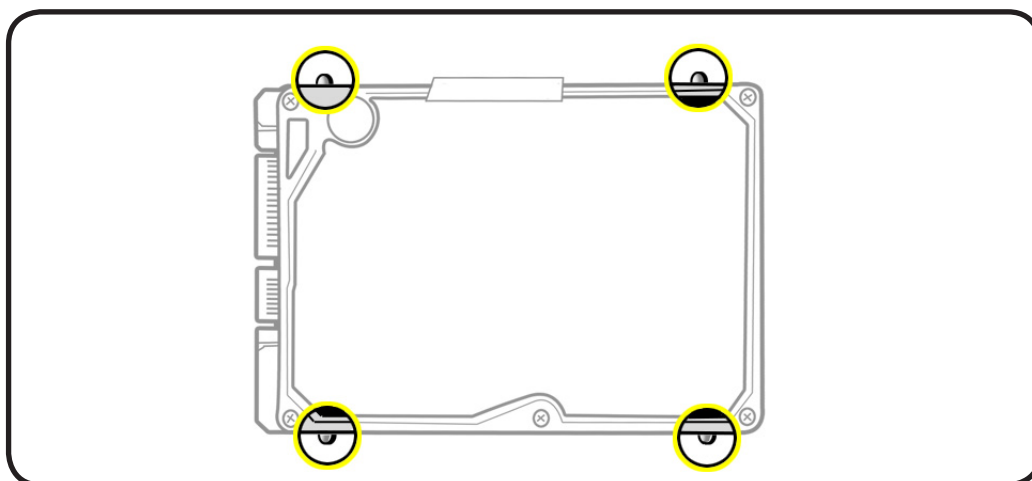

3 Attach connector, and tilt hard drive into front of top case.

4 Replace hard drive bracket.

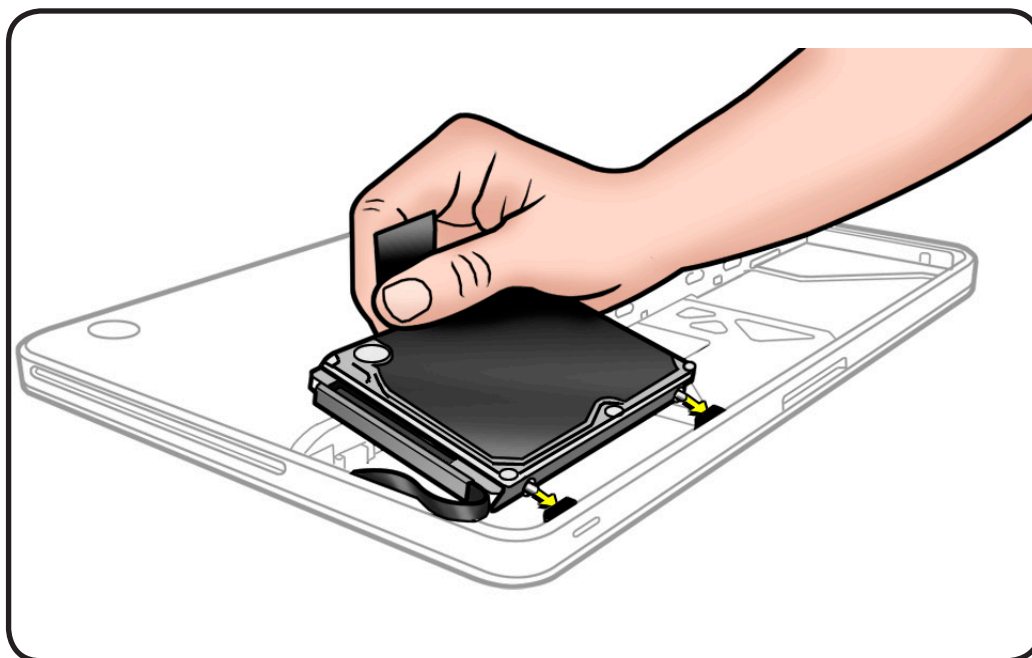

Reinstalling Software that Came with the Computer

Use the software install discs that came with your computer to install Mac OS X and the applications that came with your computer.

Installing Mac OS X and Applications

To install Mac OS X and the applications that came with your computer, follow these steps:

1. Start up from the Mac OS X Install Disc 1 that came with your computer, and choose your language.
2. From the menu bar, choose Utilities > Disk Utility.
3. Open Disk Utility and select the new drive in the list to the left.

Note: If you are formatting the primary drive, use the Disk Utility program on the Install disc.

4. Click the Partition tab.
5. Click on Options, and verify GUID is selected if this is the startup drive.
6. Name the volume "Macintosh HD."
7. Apply the change by clicking the Partition button.
8. At this point, either
 - Quit the Disk Utility application, and proceed with the Mac OS X installation. Follow the onscreen instructions. After selecting the destination disk for installation, continue following the onscreen instructions. Your computer may restart and ask you to insert the next Mac OS X Install Disc 2. or
 - Leave the Disk Utility application open, and restore the backed up files from the image you created before removing the hard drive.

Installing Applications

To install just the applications that came with the computer, follow the steps below. The computer must have Mac OS X already installed.

1. Back up your essential files, if possible.
2. Insert the Mac OS X Install Disc 1 that came with your computer.
3. Double-click "Install Bundled Software Only."
4. Follow the onscreen instructions.
5. After selecting the destination disk for installation, continue following onscreen instructions. After restart, insert the next Mac OS X Install Disc 2.
6. Restore the data by reinstalling the backed up files from your backup to the new drive.



Bottom Case

First Steps

Remove:

- [Access door](#)
- [Battery](#)

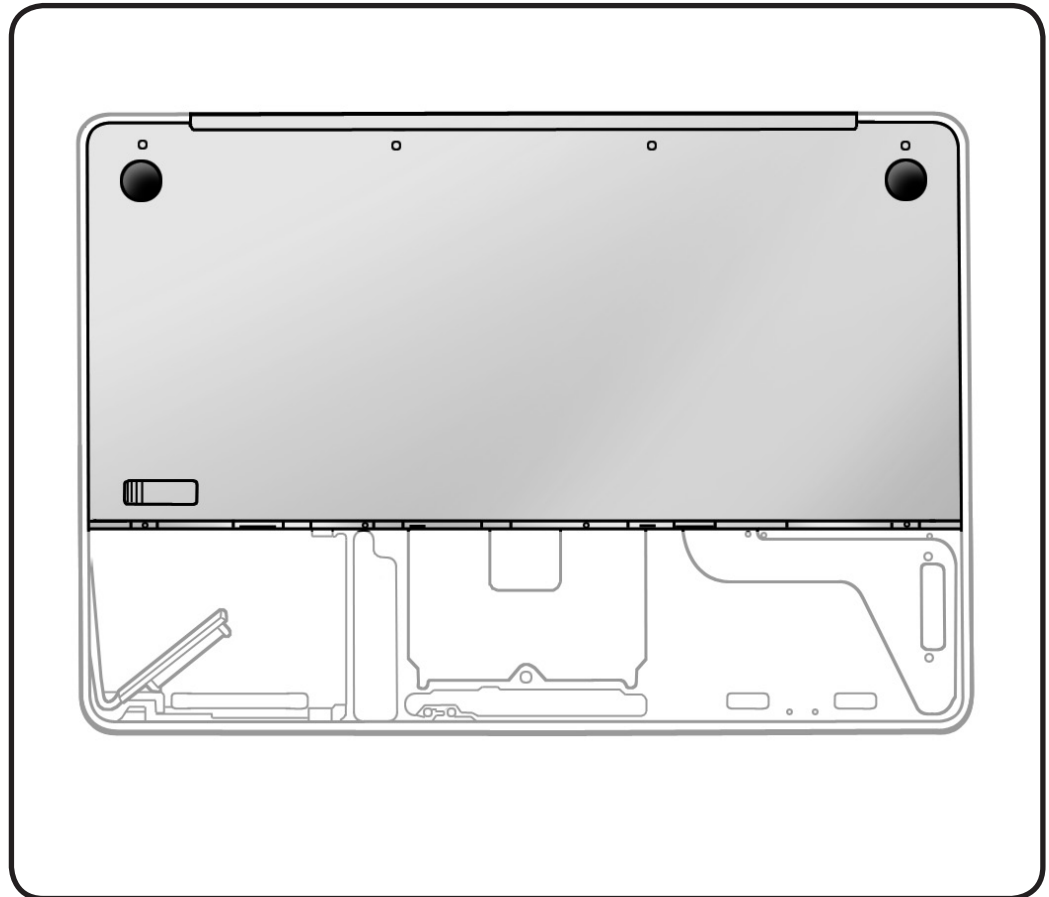

Tools

- Clean, soft, lint-free cloth
- ESD wrist strap and mat
- Magnetic Phillips #00 screwdriver

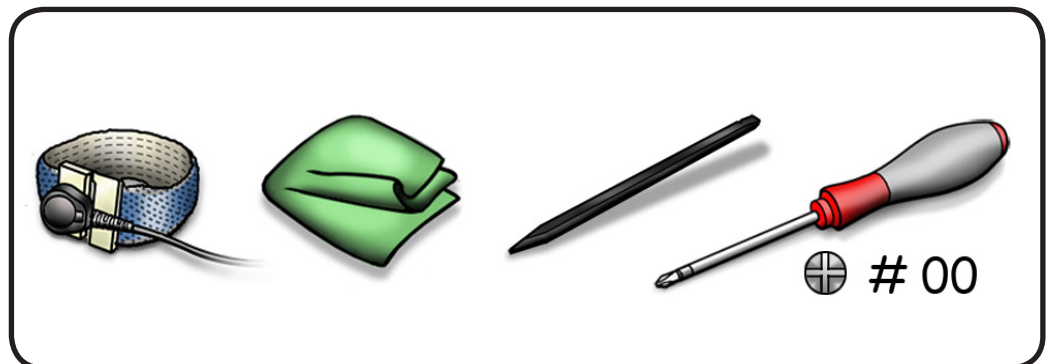



Removal

Caution: To prevent scratches, use a protective cloth.

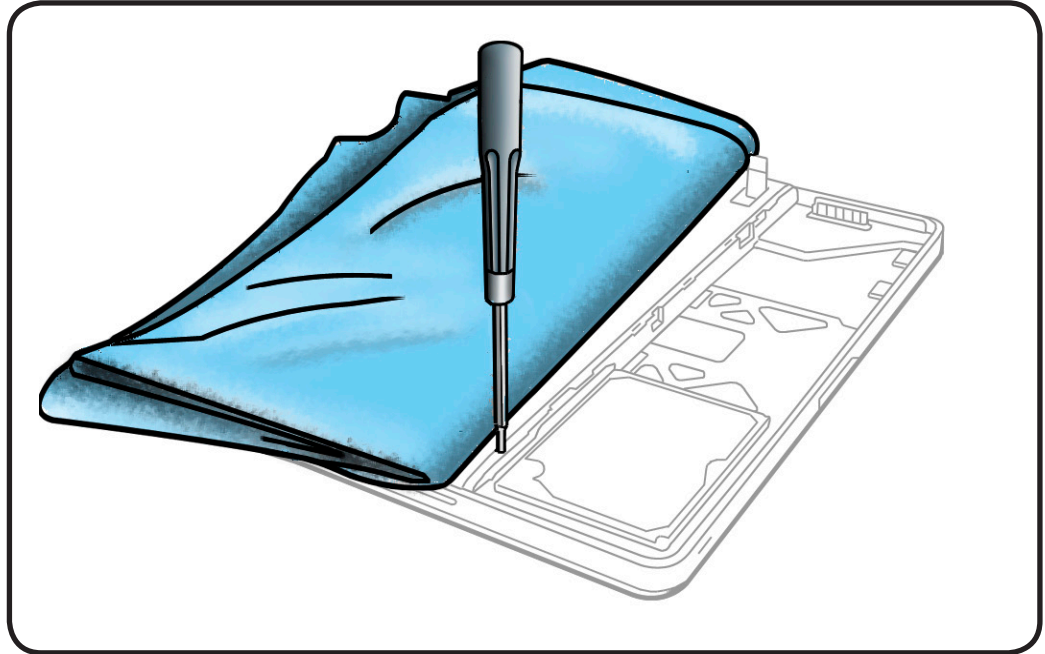

- 1 Remove 8 screws:
 - 1 (5.44 mm) 922-8745
 - 3 (13 mm) 922-8666
 - 4 (3.55 mm) 922-8653

- 2 With the locking lever flush to the case, lift the entire front edge of the bottom case to remove.

Replacement Note:

Install screws in the order shown. Make sure locking lever is flipped “up” during installation.

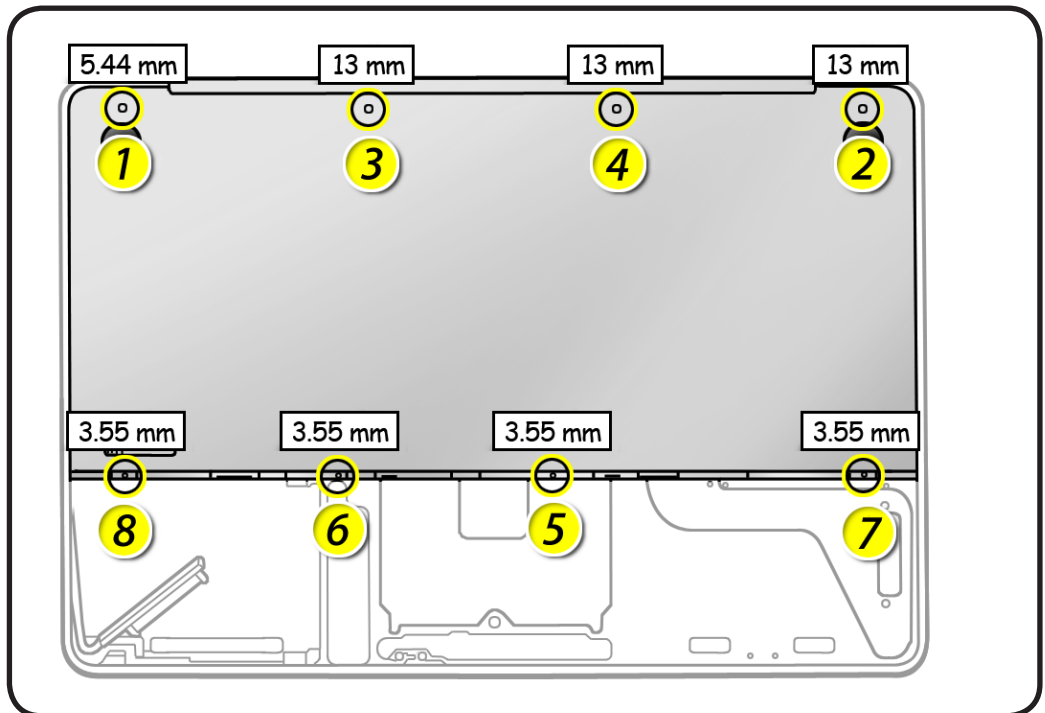



Replacement

- 1 Press corner to align top case to bottom case, as demonstrated on the 13-inch model.
- 2 Check alignment as you install screws.

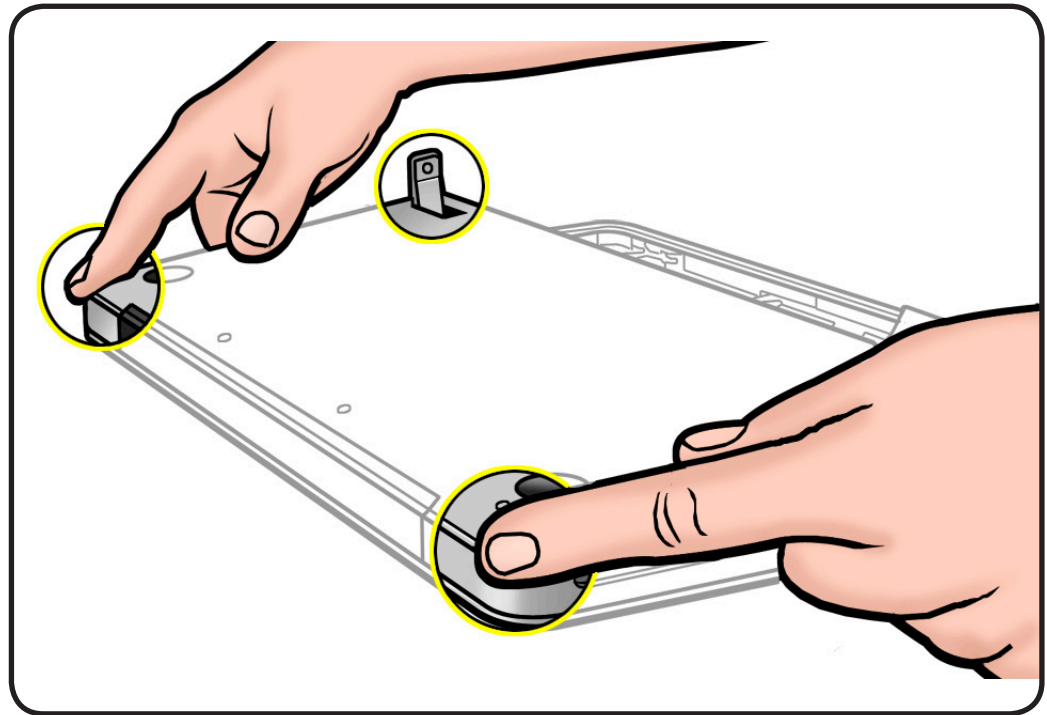

Bottom Case Information

The bottom case has been updated. It's important to note that the current and the previous bottom cases are compatible and interchangeable. Do not SDOA a bottom case if it's missing the side catches. The catches are no longer necessary

Earlier production bottom cases (lower photo, 922-8709) had 2 side catches (circled). Current production bottom cases (top photo, 922-8992) do not have the 2 side catches.

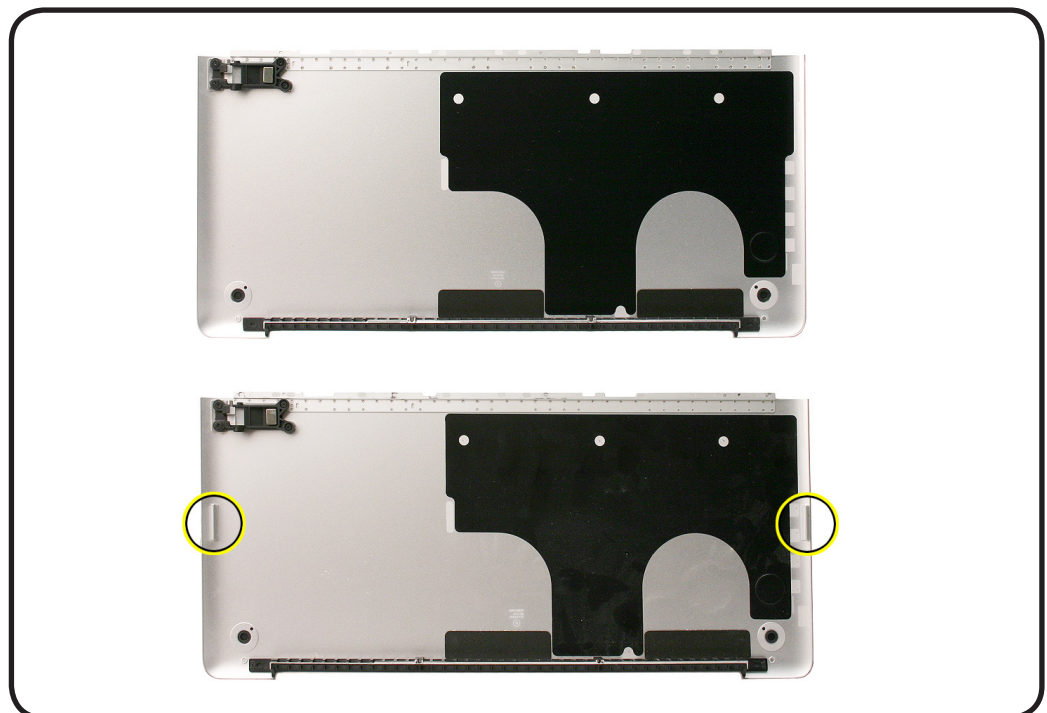



Memory

First Steps

Remove:

- [Access door](#)
- [Battery](#)
- [Bottom case](#)



Caution: Avoid touching anything other than the memory area.

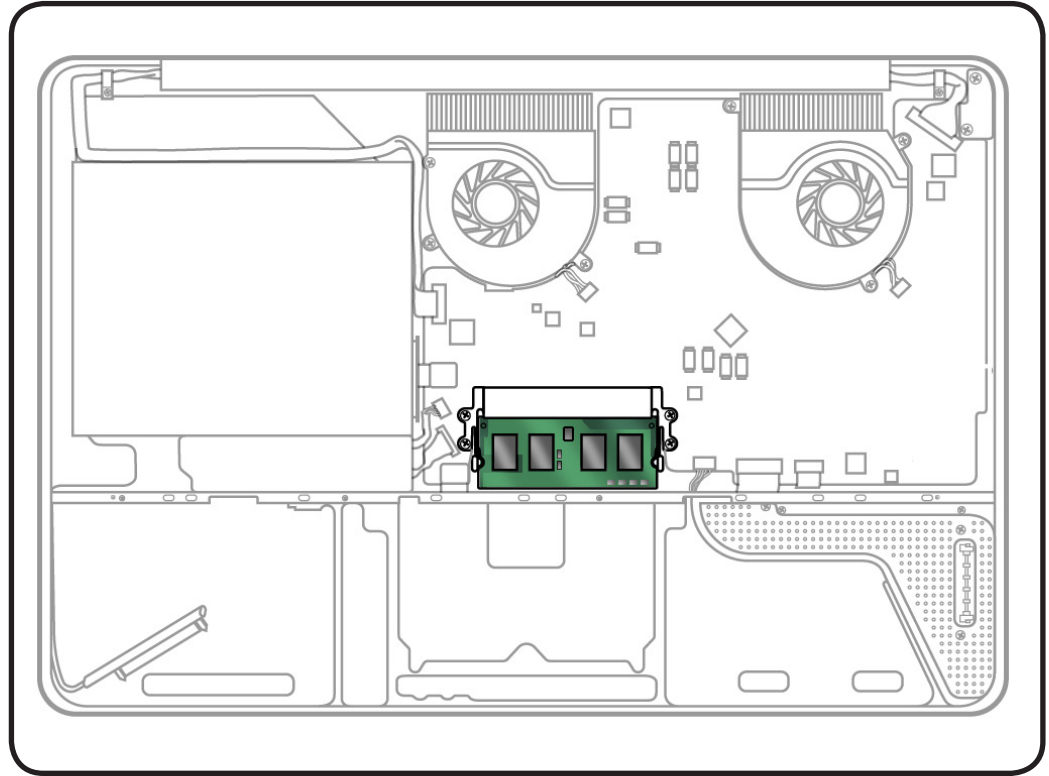

Tools

- Clean, soft, lint-free cloth
- ESD wrist strap and mat

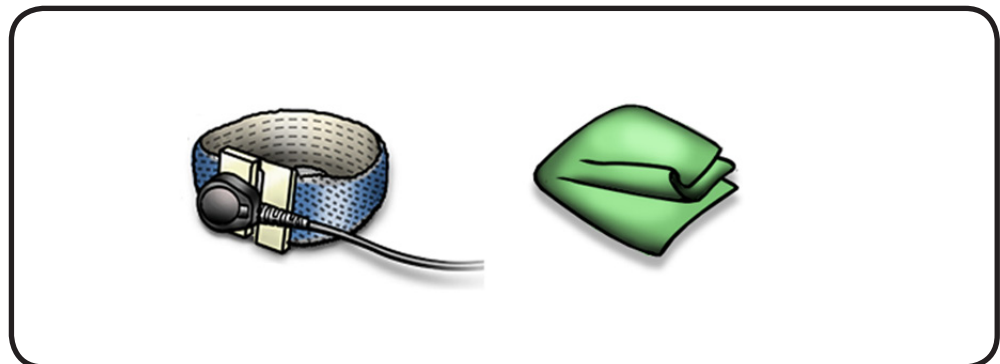



Memory Information

Memory cards must be:

- 1.25 inch (3.18 cm)
- 1 GB or 2 GB
- 200-pin
- PC-8500 DDR3, 1066 MHz RAM

This computer comes with a minimum of 2 GB of 1066 GHz Double Data Rate (DDR3) Synchronous Dynamic Random-Access Memory (SDRAM) installed. Both memory slots can accept an SDRAM module that meets the specifications listed. The slots are stacked on the logic board under the bottom case. For best performance, memory should be installed as pairs with an equal memory card in each slot. The maximum amount of memory for this computer is 4 GB, with a 2 GB DIMM installed in each slot.

Removal

- 1 Press out 2 ejection levers until the card tilts up.
- 2 Pull out the card from the slot. Card only pops up partially. Pivot the card all the way up and then out.

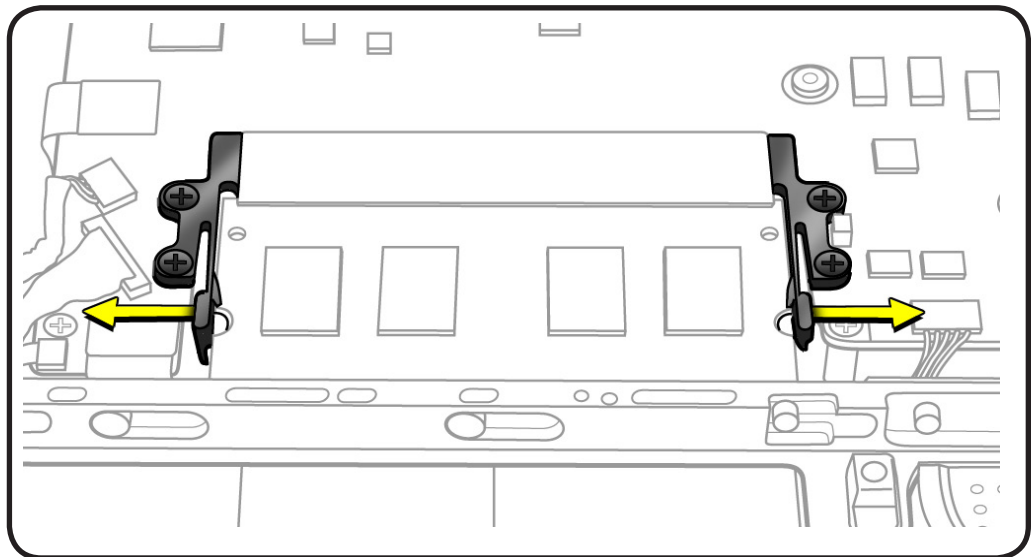

- 3 Hold the card by the edges.
- 4 Do not touch the gold connectors.

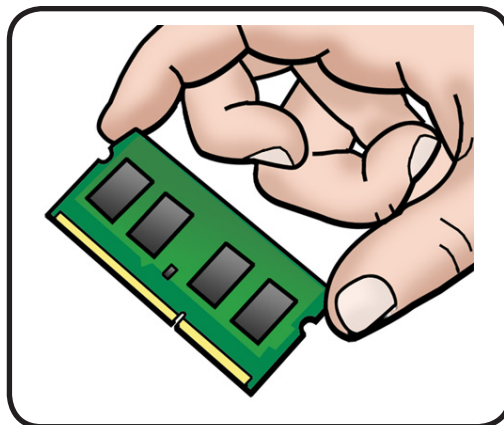



Replacement

- 1** If installing just one card, install it in lower slot.
- 2** Spread the ejection levers, and press card down.
- 3** You will hear a click when the memory is inserted correctly.
- 4** If you installed additional memory, check that the computer recognizes it.

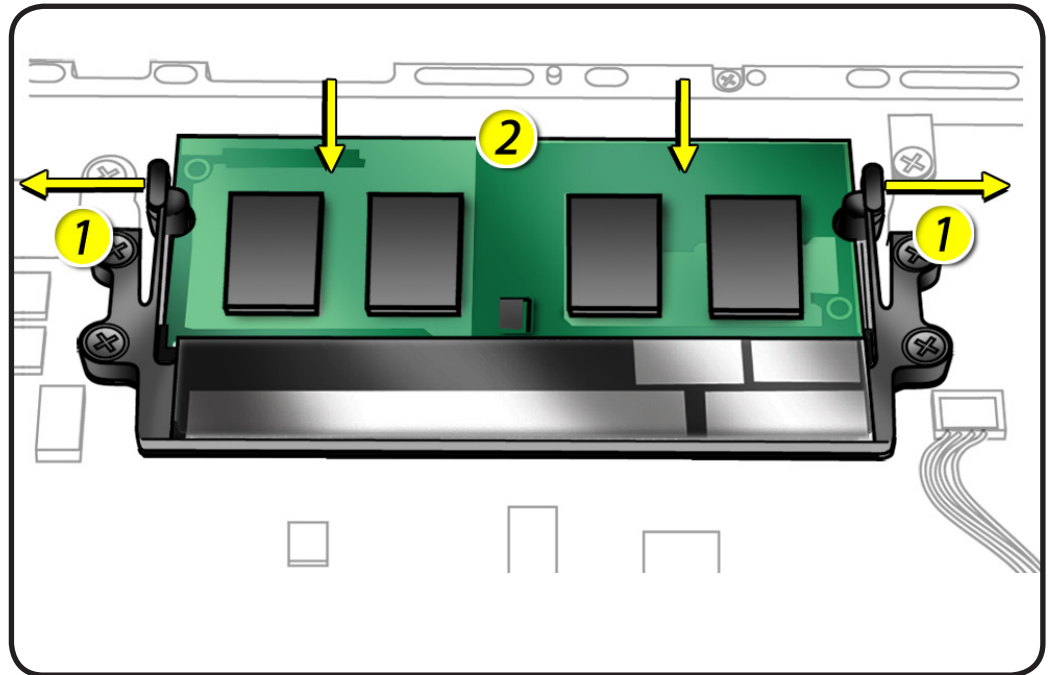



Midwall

First Steps

Remove:

- [Access door](#)
- [Battery](#)
- [Bottom case](#)

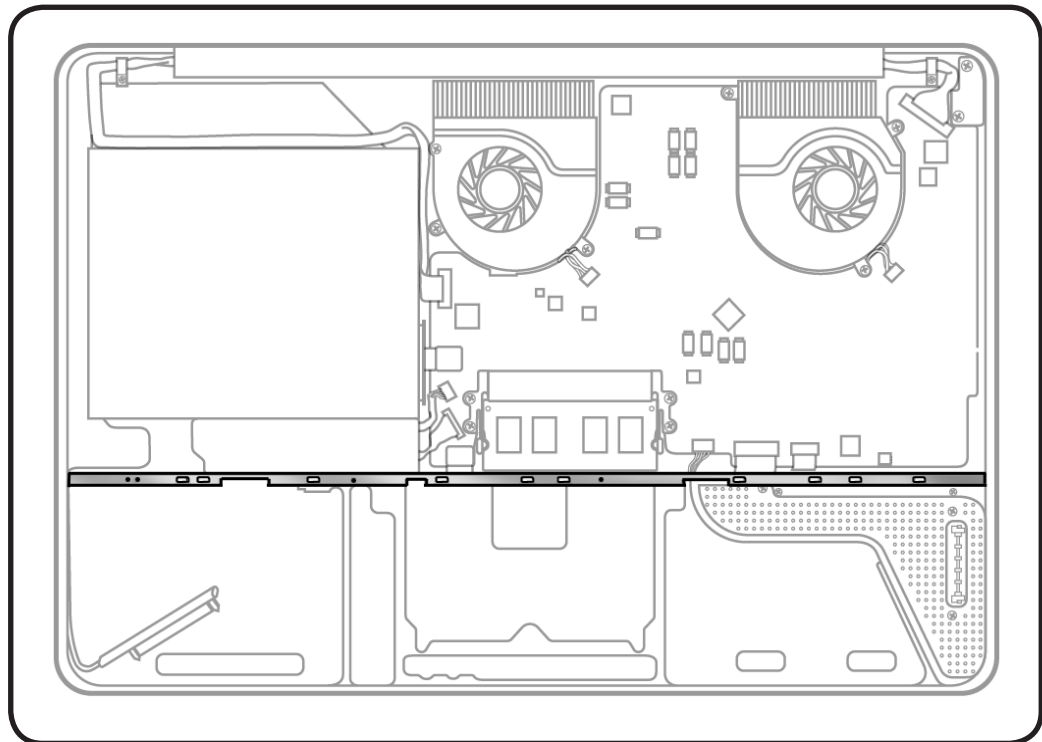

Tools

- Clean, soft, lint-free cloth
- ESD wrist strap and mat
- Magnetized Phillips #00 screwdriver





Removal



To prevent scratches to the computer housing, use a soft cloth when removing and installing screws.

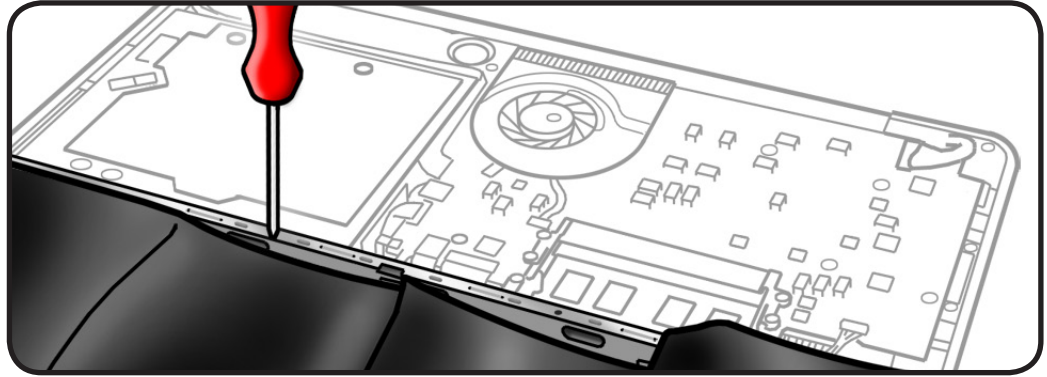

- 1 Remove 5 screws:
 - 2 silver (3.7-mm) 922-8722
 - 3 black (10.5-mm) 922-8656
- 2 Lift out midwall.

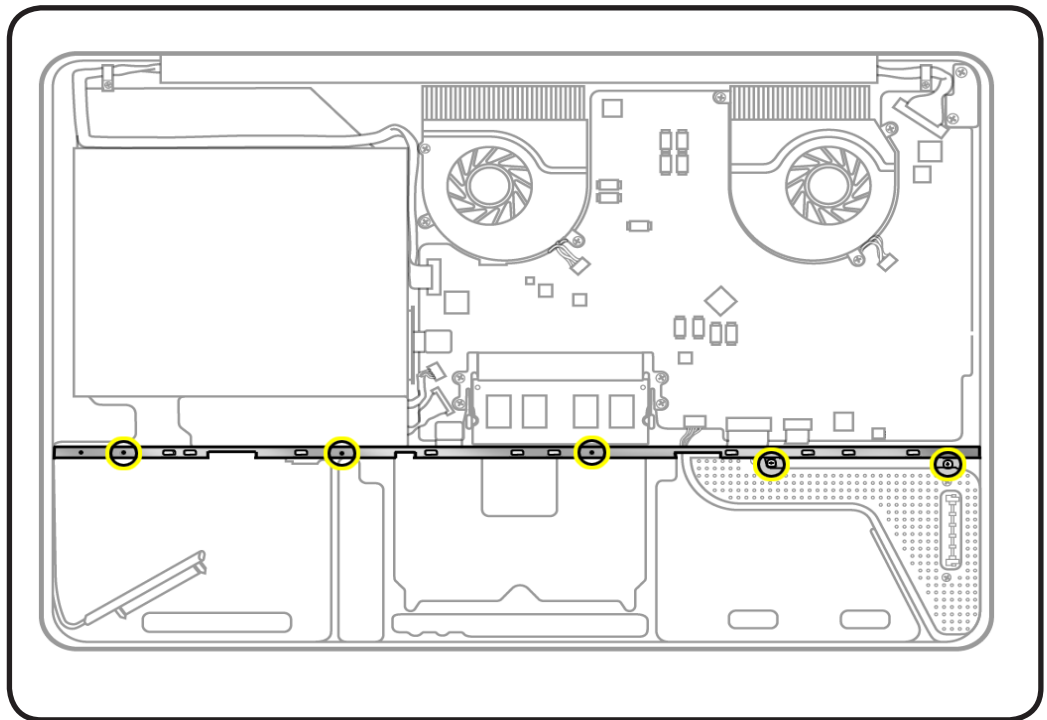



Replacement

- 1** Line up two metal pins on the underside of midwall with openings in top case.
- 2** Install screws left to right, starting with the 3 (10.5-mm) black screws.

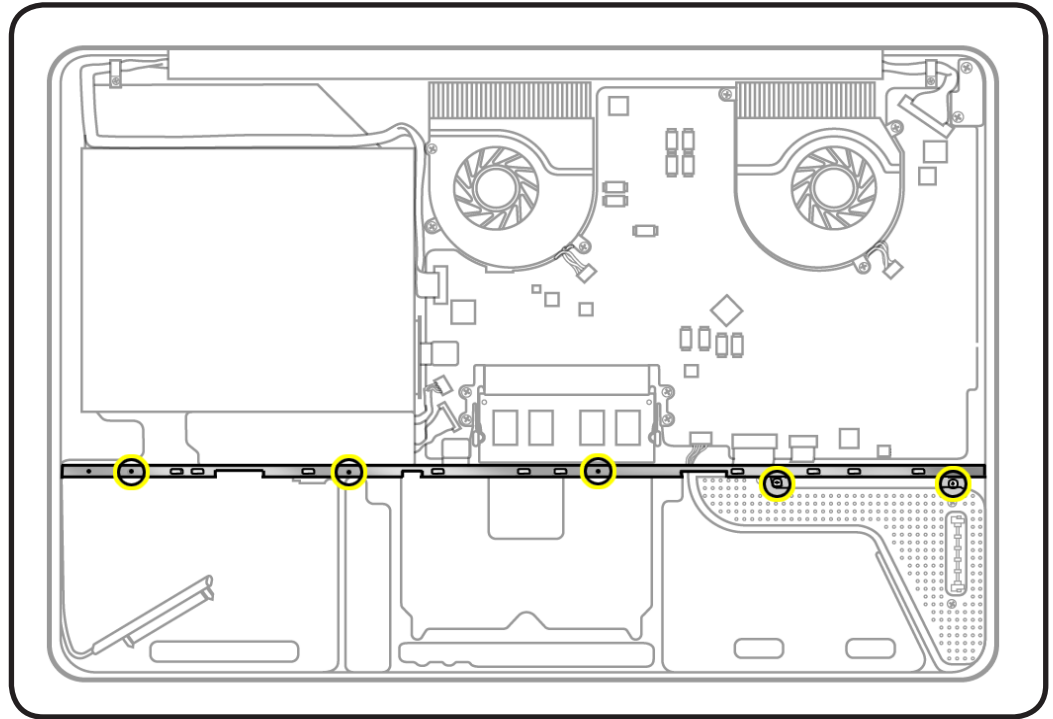



Battery Connector Cover

First Steps

Remove:

- [Access door](#)
- [Battery](#)
- [Bottom case](#)

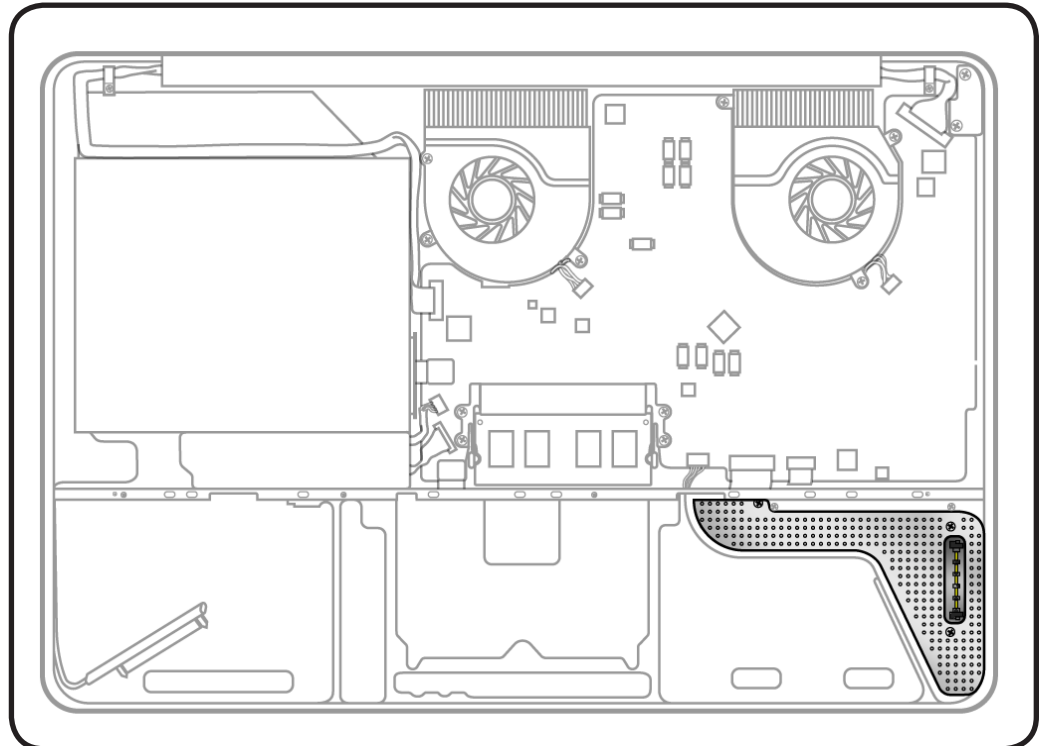

Tools

- Clean, soft, lint-free cloth
- ESD wrist strap and mat
- Magnetized Phillips #00 screwdriver
- Black stick

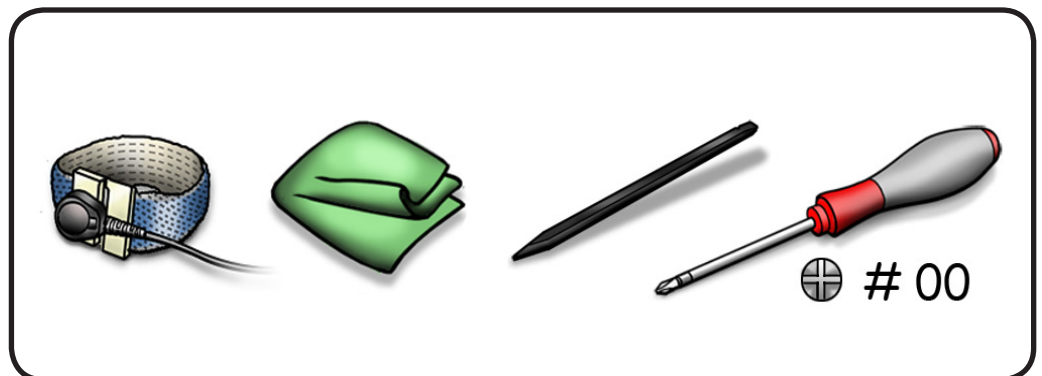



Removal

- 1 Remove 3 identical silver (1.98-mm) screws (922-9755).



Caution: The adhesive on the cover is **very** strong.

- 2 Use a black stick to loosen adhesive on around the edges of the battery connector cover.



Important: DO NOT pull on the battery connector pins. They are not part of the battery cover and they can be damaged if pulled.

- 3 Lift out battery connector cover.

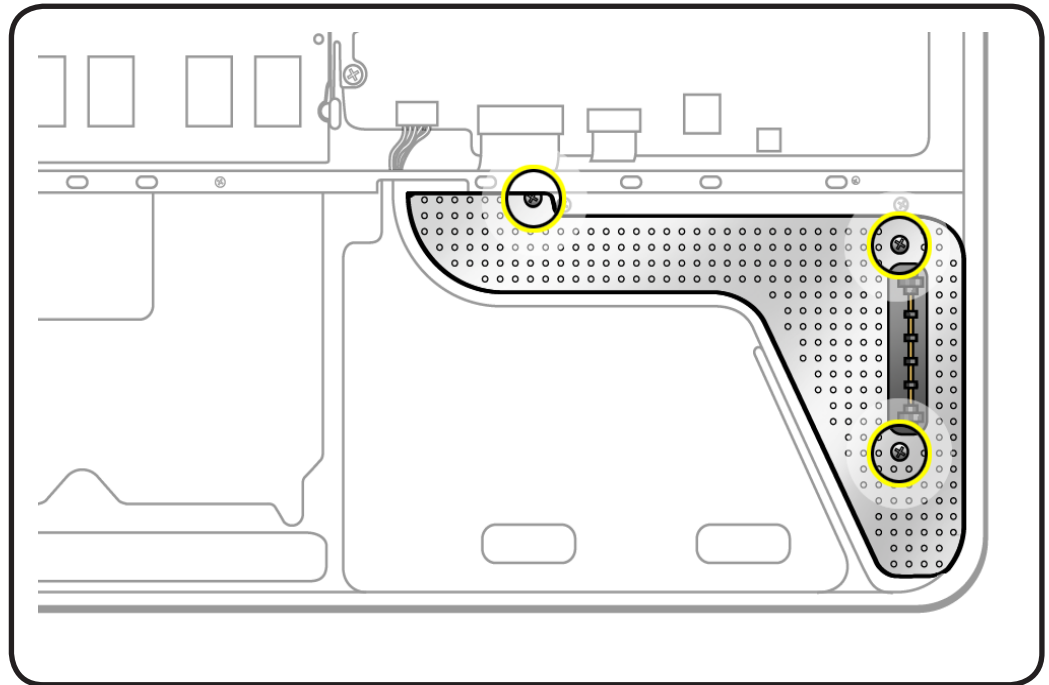



Battery Indicator Light Board

First Steps

Remove:

- [Access door](#)
- [Battery](#)
- [Bottom case](#)
- [Battery connector cover](#)

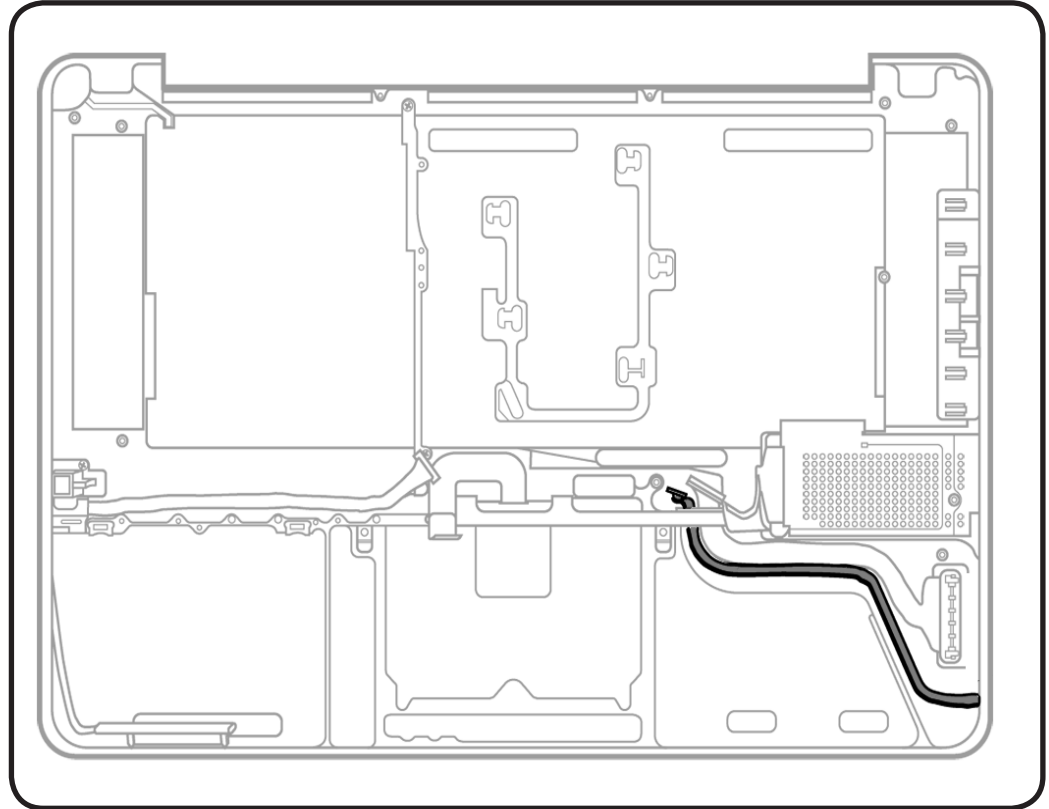

Tools

- Clean, soft, lint-free cloth
- ESD wrist strap and mat
- Magnetized Phillips #00 screwdriver
- Black stick

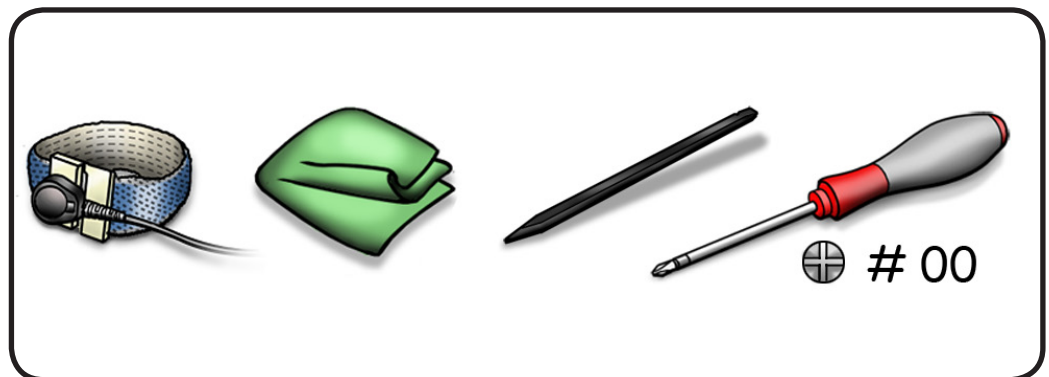



Removal

- 1 Remove 3 (2.62 mm) screws.
- 2 Pry the board from side of top case.
- 3 Disconnect cable from battery indicator light (BIL) board.

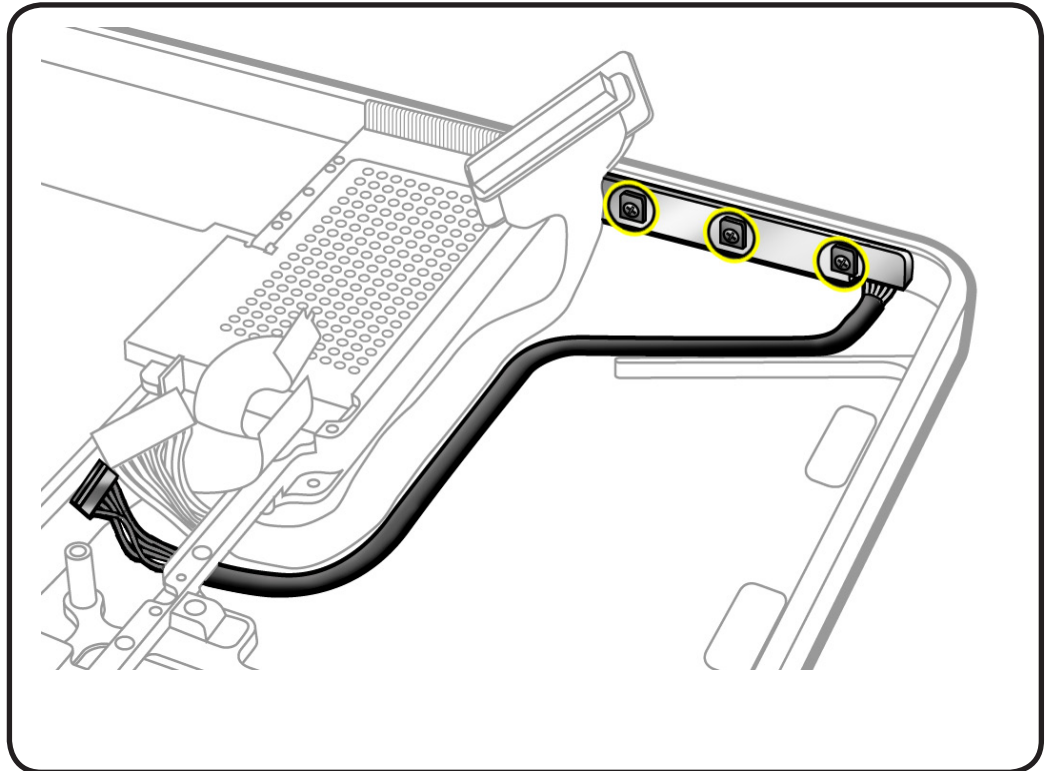

Replacement

- 1 Before replacing the board, check that:
 - the rubber gasket is assembled on top of the LEDs
 - the battery indicator light button is installed in the top case

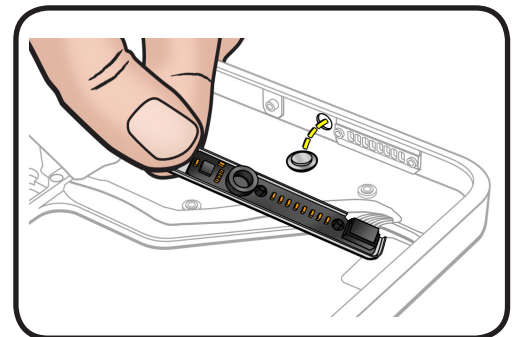
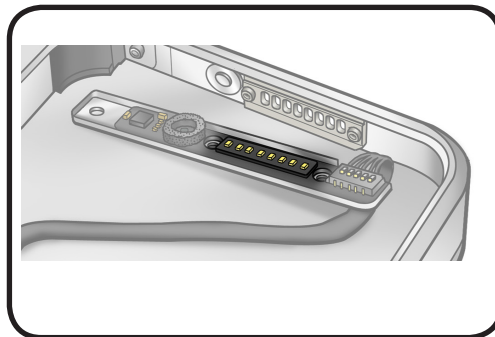



Battery Indicator Cable

First Steps

Remove:

- [Access door](#)
- [Battery](#)
- [Bottom case](#)
- [Battery connector cover](#)

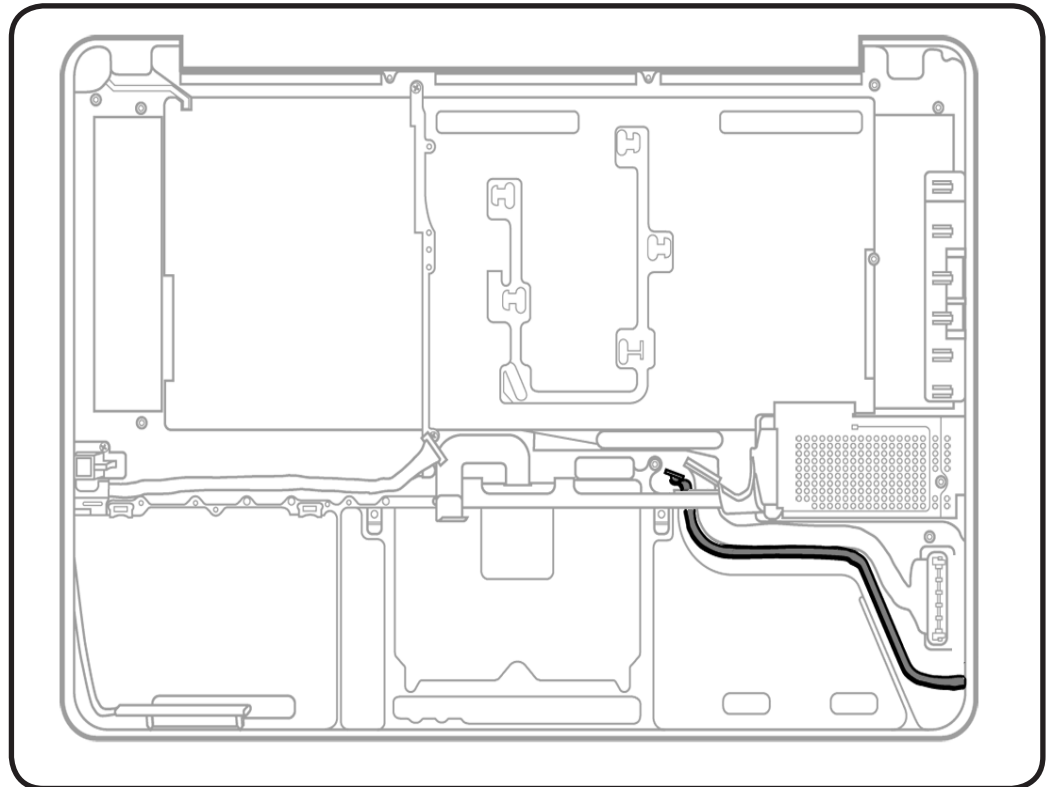

Tools

- Clean, soft, lint-free cloth
- ESD wrist strap and mat
- Magnetized Phillips #00 screwdriver

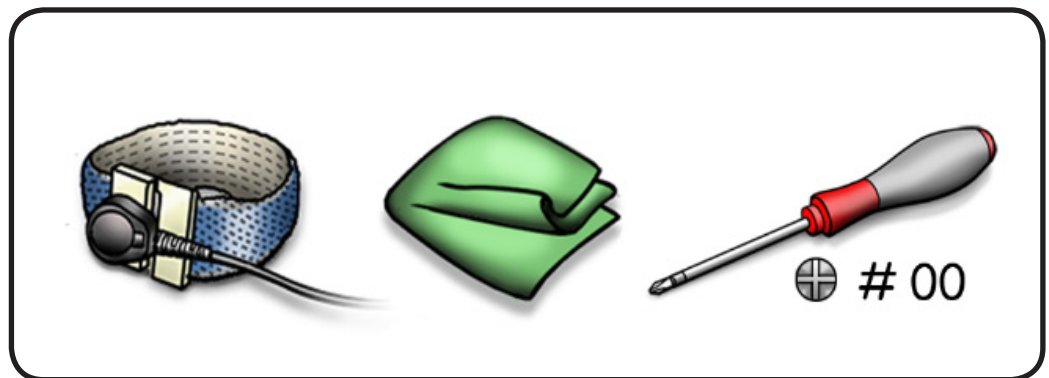



Removal

- 1 Disconnect cable from underside of logic board.
- 2 Route cable under midwall.
- 3 Remove 3 (3-mm) 922-8657 screws on battery indicator board.
- 4 Pry board from top case.
- 5 Disconnect cable from battery indicator light (BIL) board.

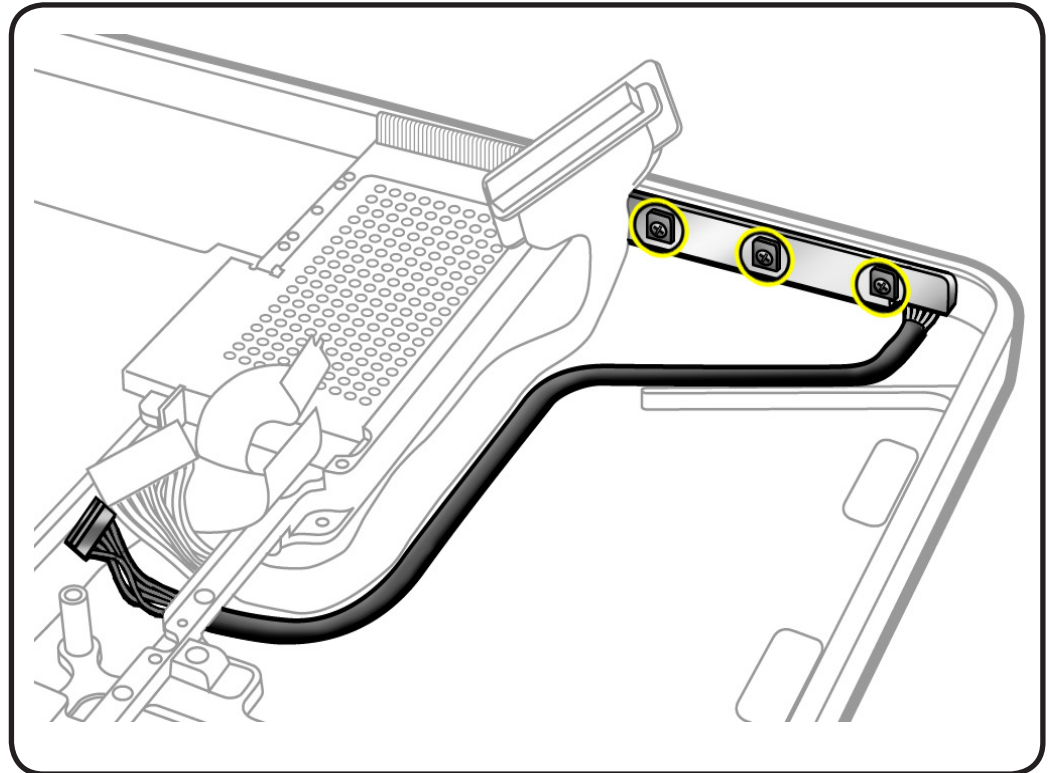

Note: The battery indicator light button may fall out of top case. Make sure you retain the button.

Replacement

- 1 Before replacing the board, check that:
 - the rubber gasket is assembled on top of the LEDs
 - the battery indicator light button is installed in the top case

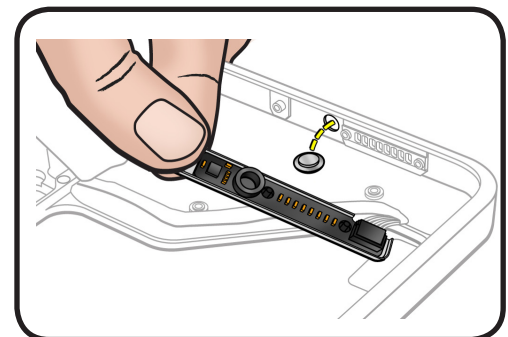
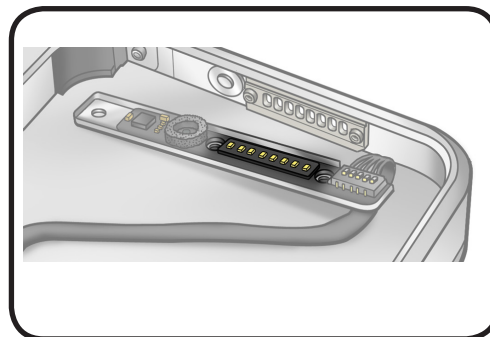



Camera/AirPort/BT Cable Guide

First Steps

Remove:

- [Access door](#)
- [Battery](#)
- [Bottom case](#)

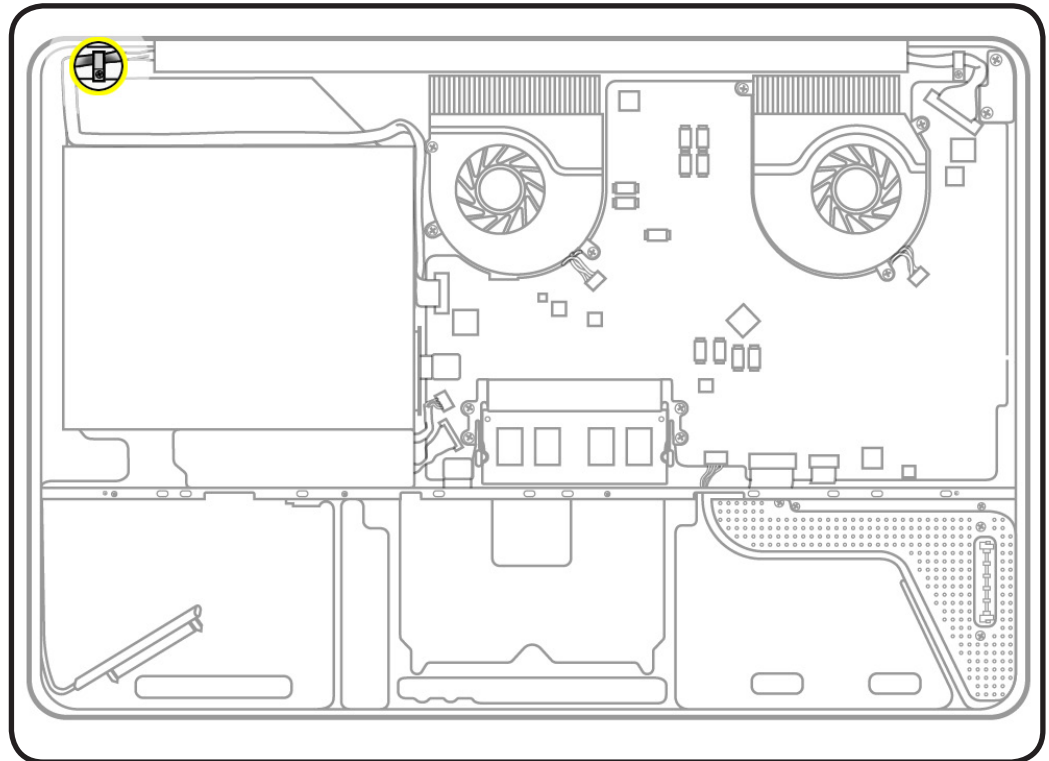

Tools

- Clean, soft, lint-free cloth
- ESD wrist strap and mat
- Magnetized Phillips #00 screwdriver

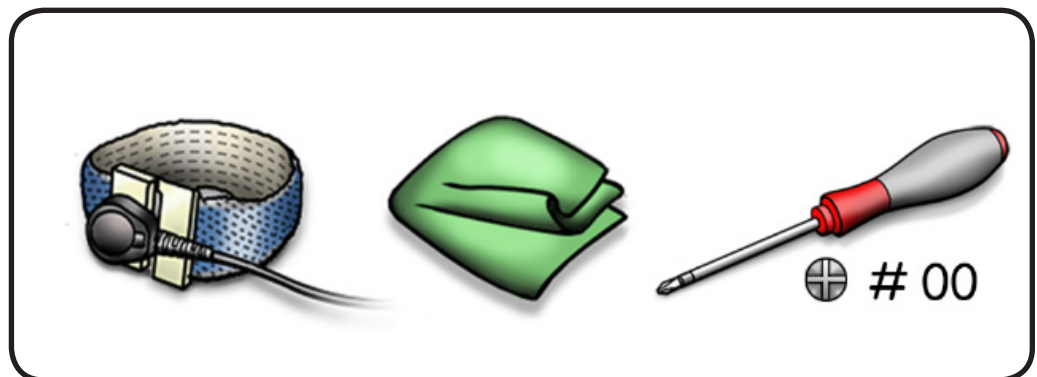



Removal

- 1 Remove 2 (8-mm) screws (922-8720).
- 2 Remove cable guide from the top case.

Replacement Note:
Make sure the black ground tab (on the camera, AirPort and Bluetooth cable) is placed over the right screw hole before installing the screw.

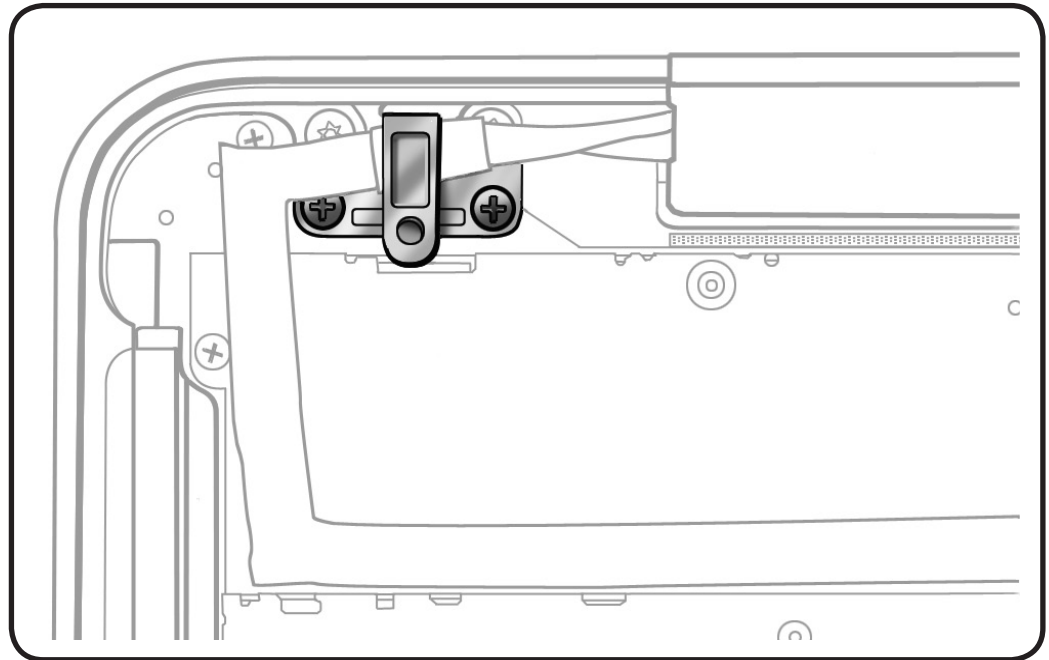



LVDS Cable Guide

First Steps

Remove:

- [Access door](#)
- [Battery](#)
- [Bottom case](#)

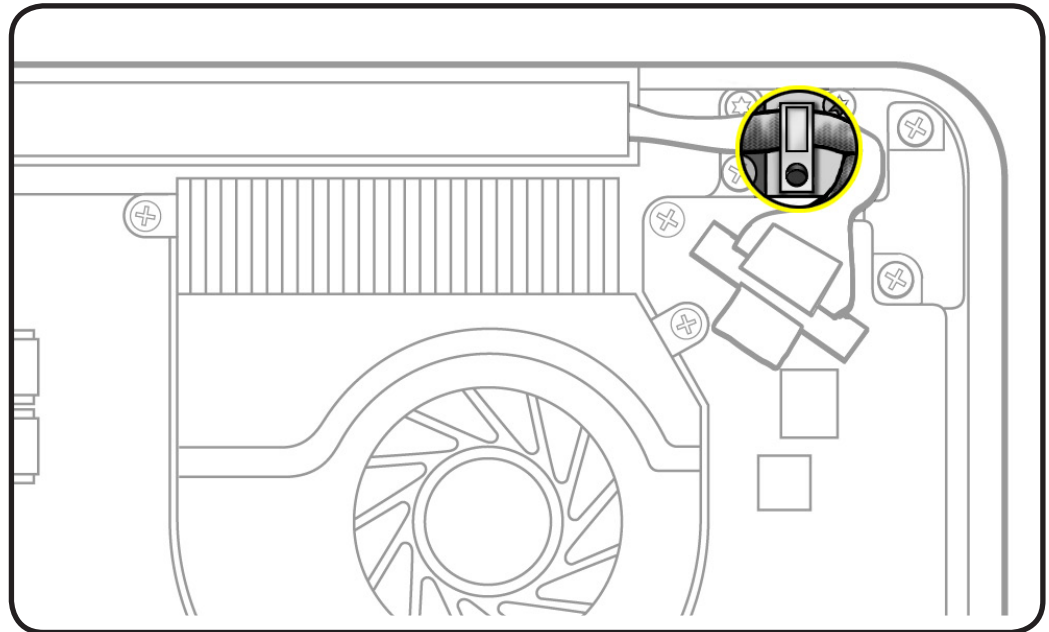

Tools

- Clean, soft, lint-free cloth
- ESD wrist strap and mat
- Magnetized Phillips #00 screwdriver

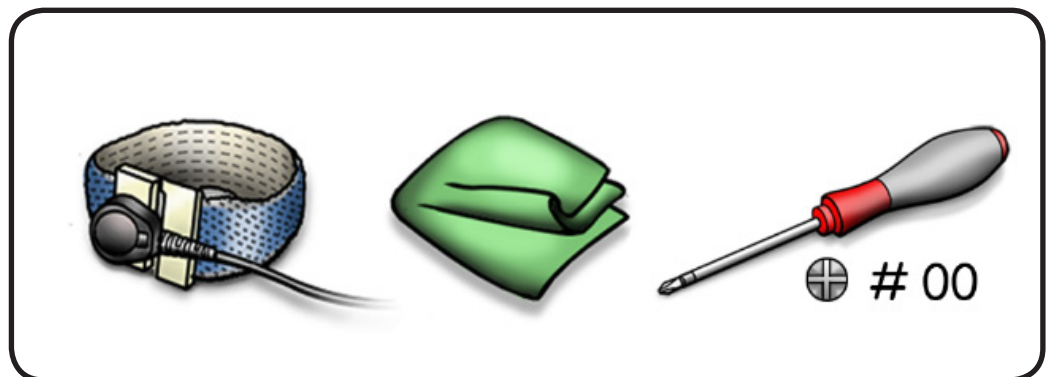



Removal

- 1 Remove 1 (7-mm) screw (922-8645).
- 2 Lift cable guide out of top case.

Replacement Note:
Align locator pin on cable guide to hole in top case

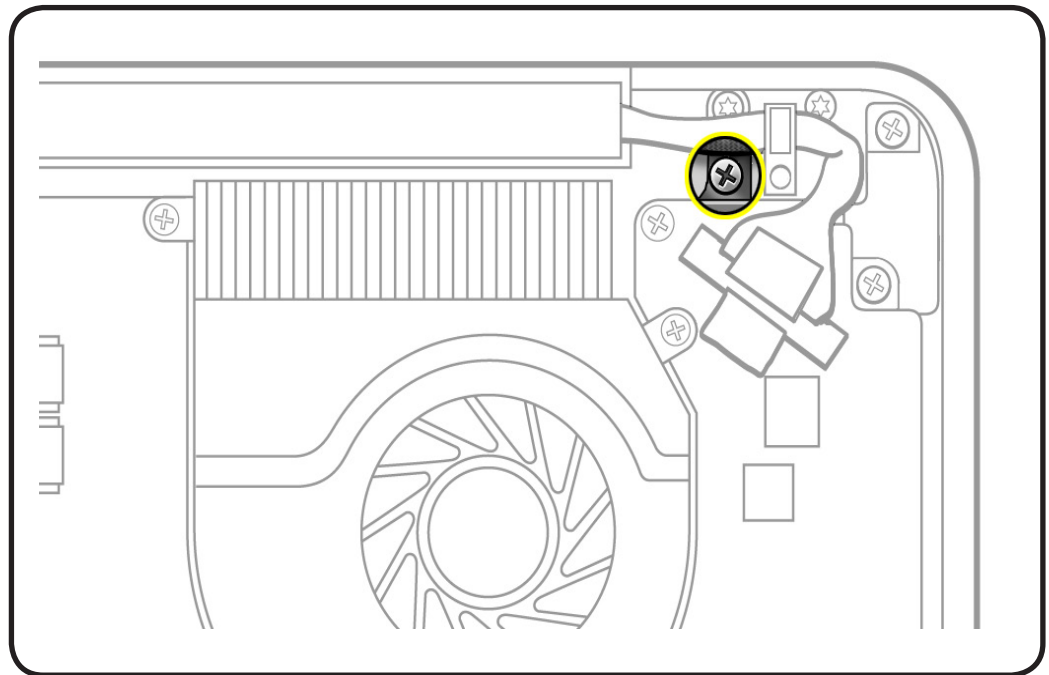



Display Assembly

First Steps

Remove:

- [Access door](#)
- [Battery](#)
- [Bottom case](#)
- [Camera cable guide](#)
- [LVDS cable guide](#)

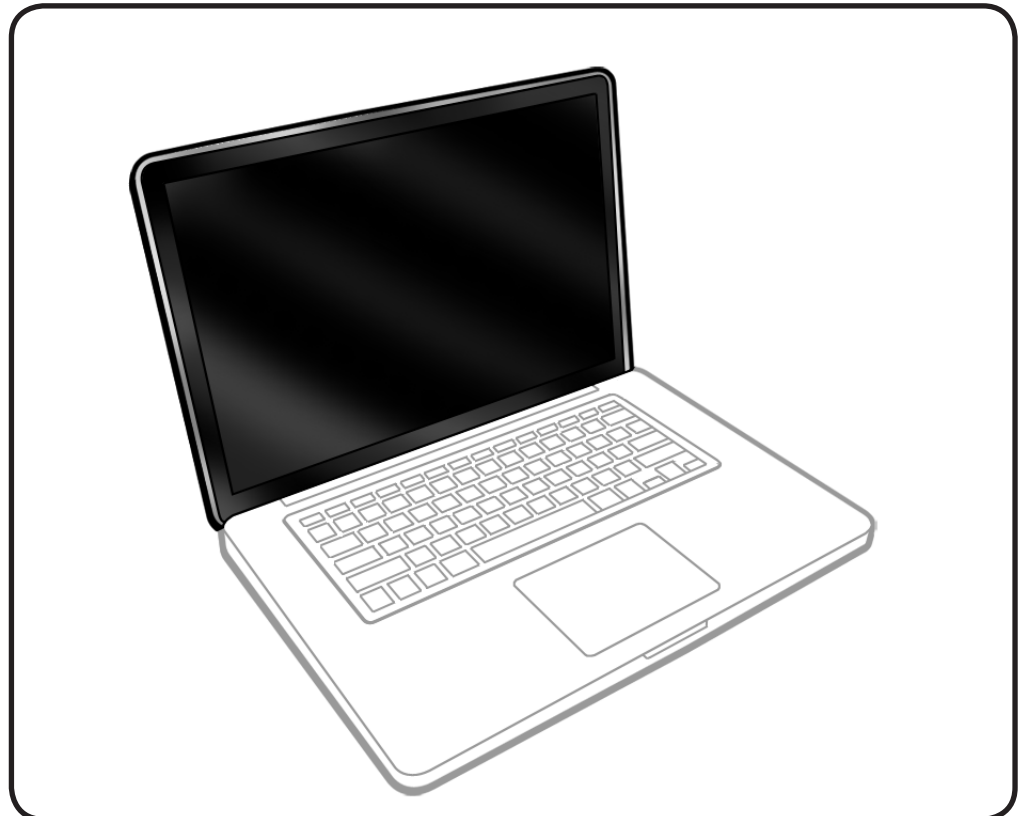

Tools

- Clean, soft, lint-free cloth
- ESD wrist strap and mat
- Magnetized Phillips #00 screwdriver
- Torx T6 screwdriver with a large-diameter handle
- Foam wedge fixture

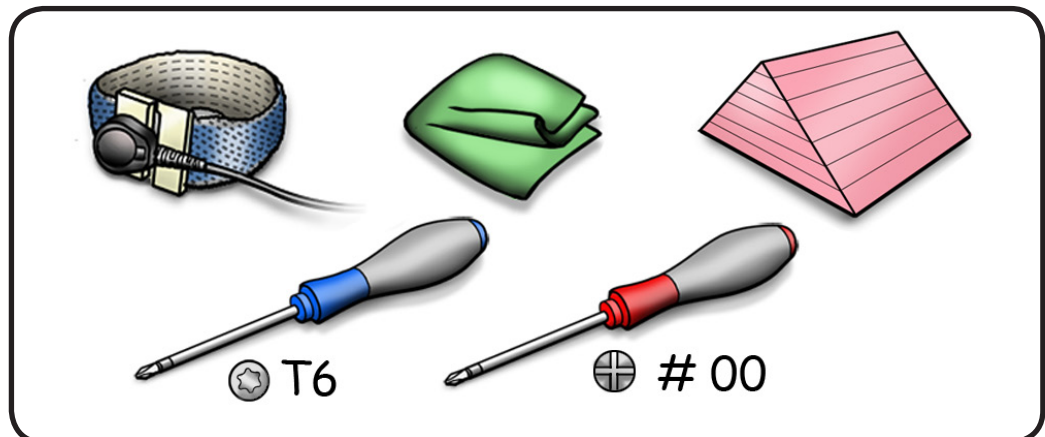



Removal

- 1 Locate camera/AirPort/Bluetooth/connector and black shim on the logic board.
- 2 Using a black stick, pry the shim from the logic board and set it aside. If you don't remove the shim prior to removing the cable, you could damage the logic board and/or the camera cable.

Important: Be sure to replace the shim after you reconnect the cable. Otherwise, the cable could work loose, resulting in no video.

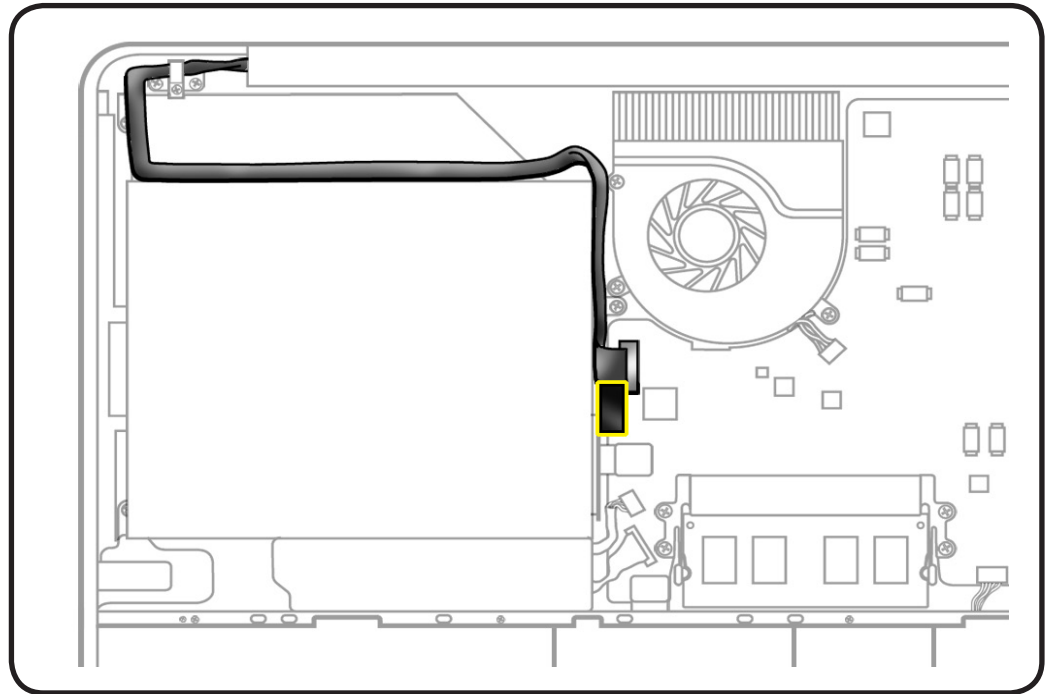

- 3 Peel EMI gasket off top of the camera cable (A)
- 4 Disconnect camera cable from logic board (B).

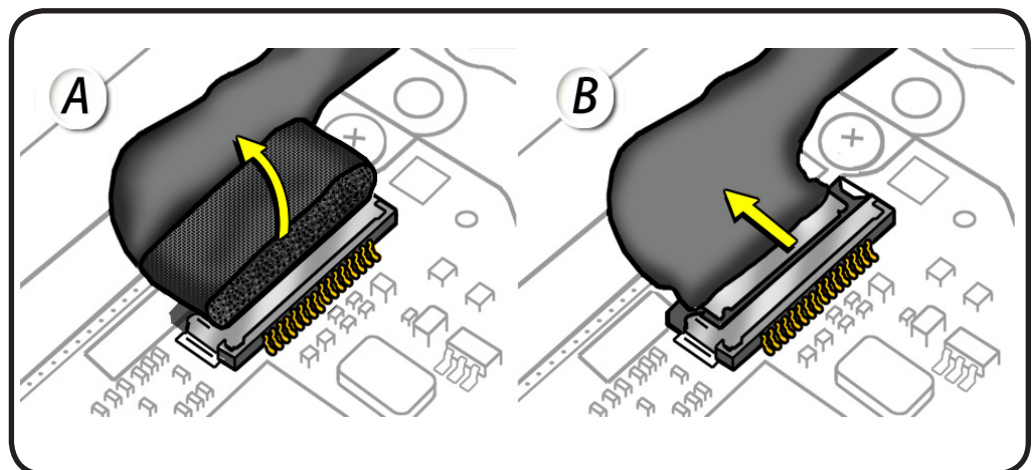



Caution: Do not pull on the black tab or the LVDS lock bar. Pulling on the tab to remove the LVDS cable will likely result in the metal LVDS lock bar being torn off the cable body. This bar is only to be used to disengage the lock from the LVDS connector. A broken lock bar results in a display assembly replacement.

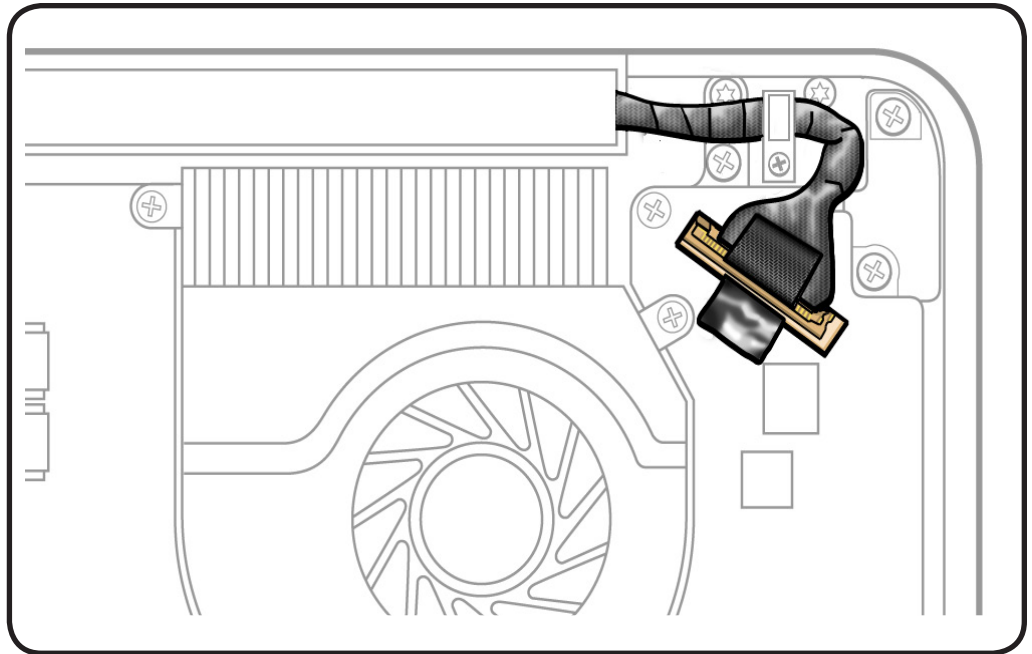

5 Peel EMI gasket off the LVDS cable, toward the fan

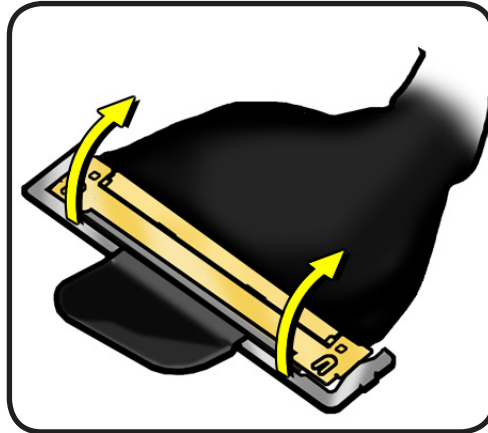

6 To disconnect LVDS cable grasp black tab and gently swing LVDS lock bar up and back to unlock the cable.

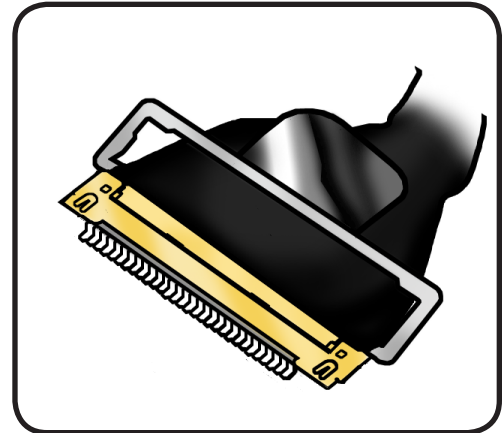

7 Slide cable out of connector by pulling the cable. Do not pull the black tab or lock bar.

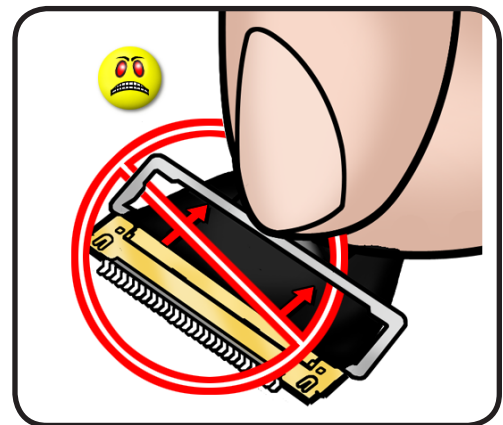
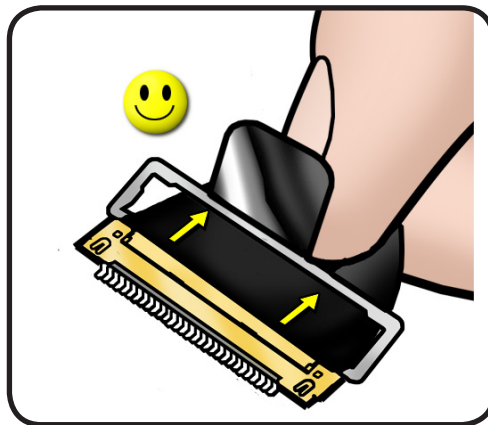



Replacement Caution:

To prevent video “noise,” a whining sound, no video, or a short to the logic board, be sure to place foam gasket on LVDS connector—**positioned precisely where shown**—**after** cable is fully connected to logic board.

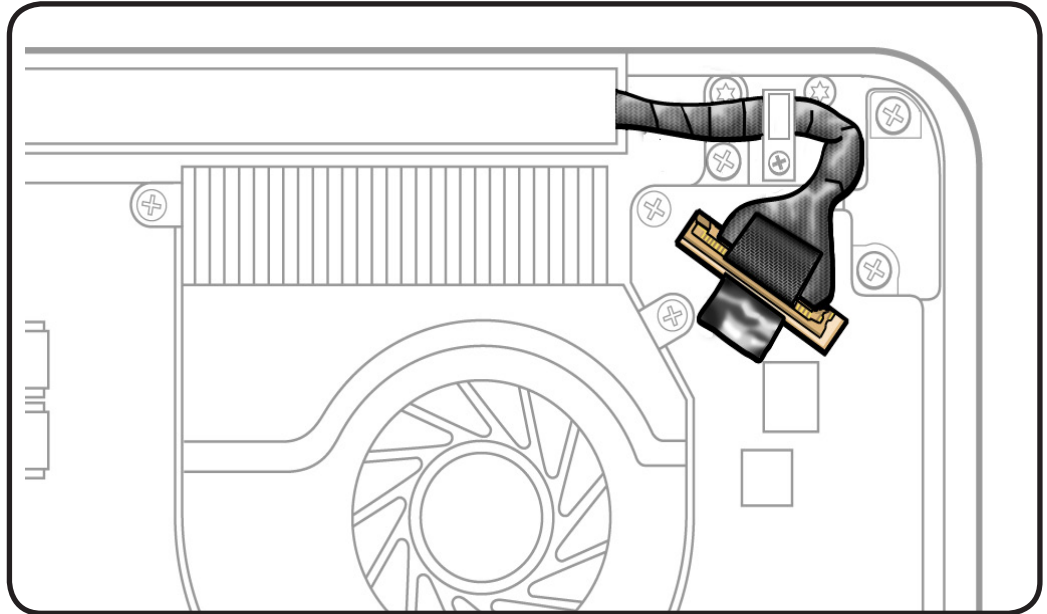

8 Open the display to 90 degrees, and place the computer on the foam wedge service fixture.

9 Caution: These screws can be especially tight. Use a T6 screwdriver with a large-diameter handle for a better grip. Remove 6 (6-mm) Torx 922-8646 screws:

10 Separate display assembly from top case.

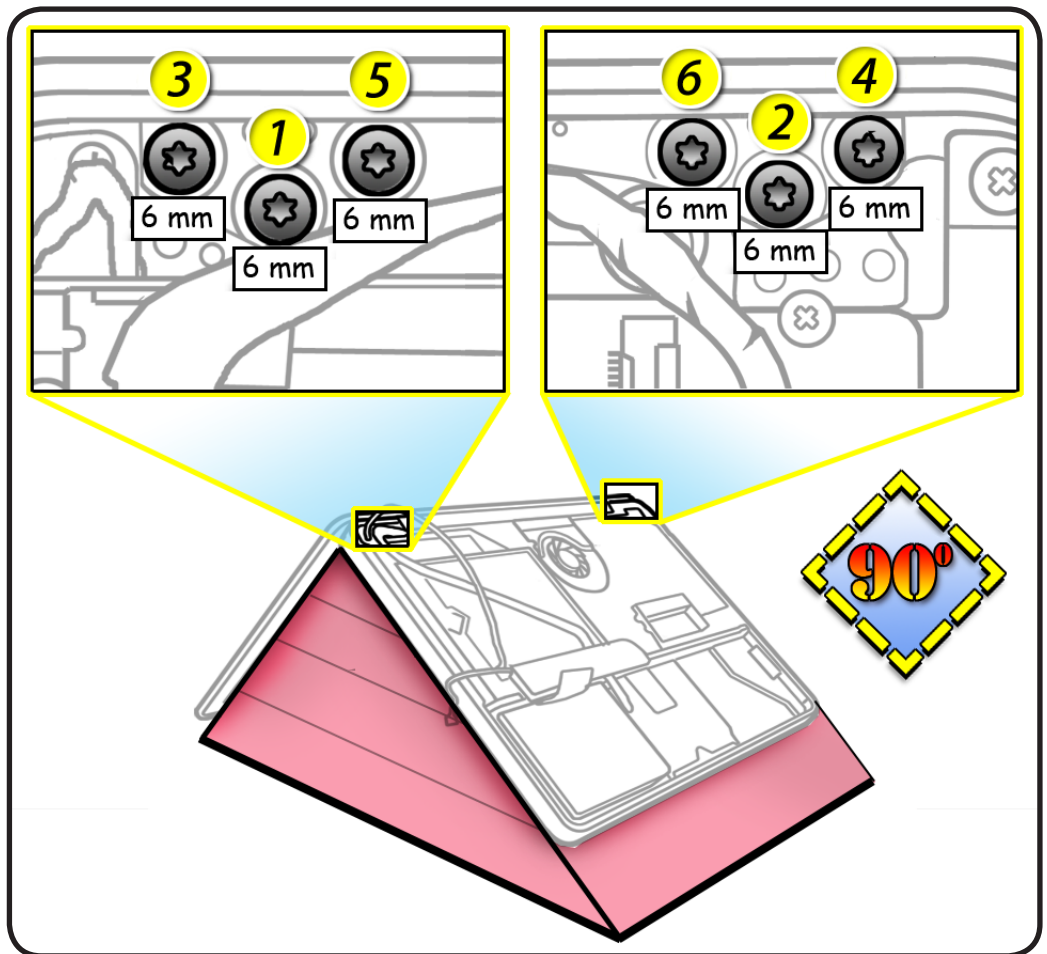



Replacement

Important: Before you return a display assembly, be sure to

- remove [clutch cover](#)
- remove [AirPort Card](#) and transfer it to the new display assembly
- reinstall [clutch cover](#)

Important: Before installing a new display assembly, be sure to:

- install the [AirPort card](#)
- replace the shim after you reconnect the camera cable
- test the computer for normal AirPort card operation

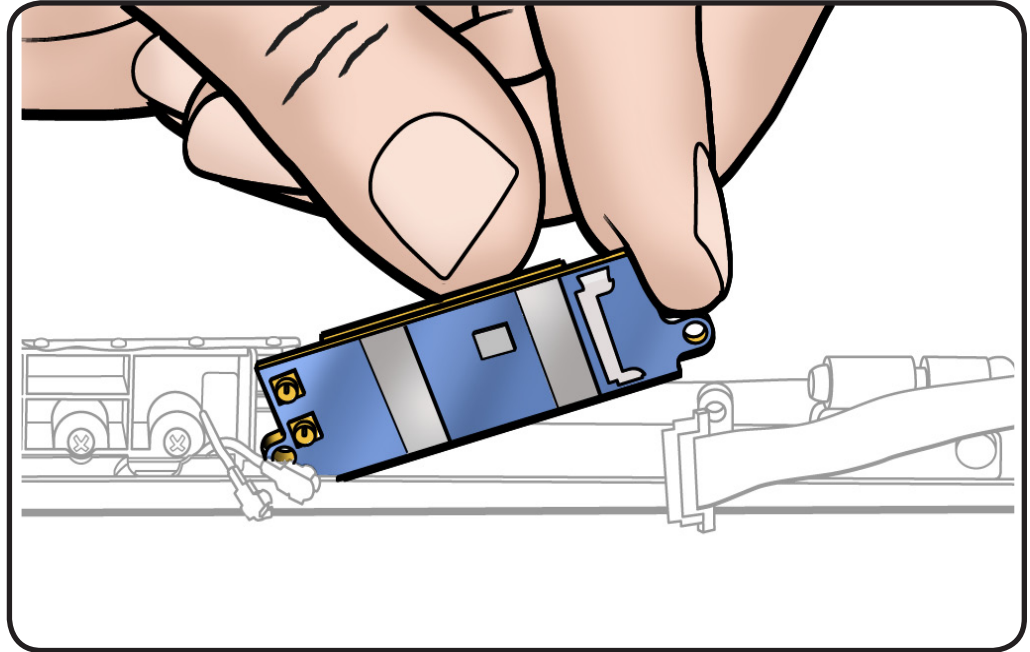

Display Hinge Behavior

The MacBook Pro models have a unique counterbalanced clutch system and was designed so that when the display is vertical with respect to the ground, it will remain in place regardless of the angle of the base.

Moving the display past vertical allows the hinges to release and the display to close. This is normal behavior and no repair is necessary. Refer to <http://support.apple.com/kb/HT3304> for more information.

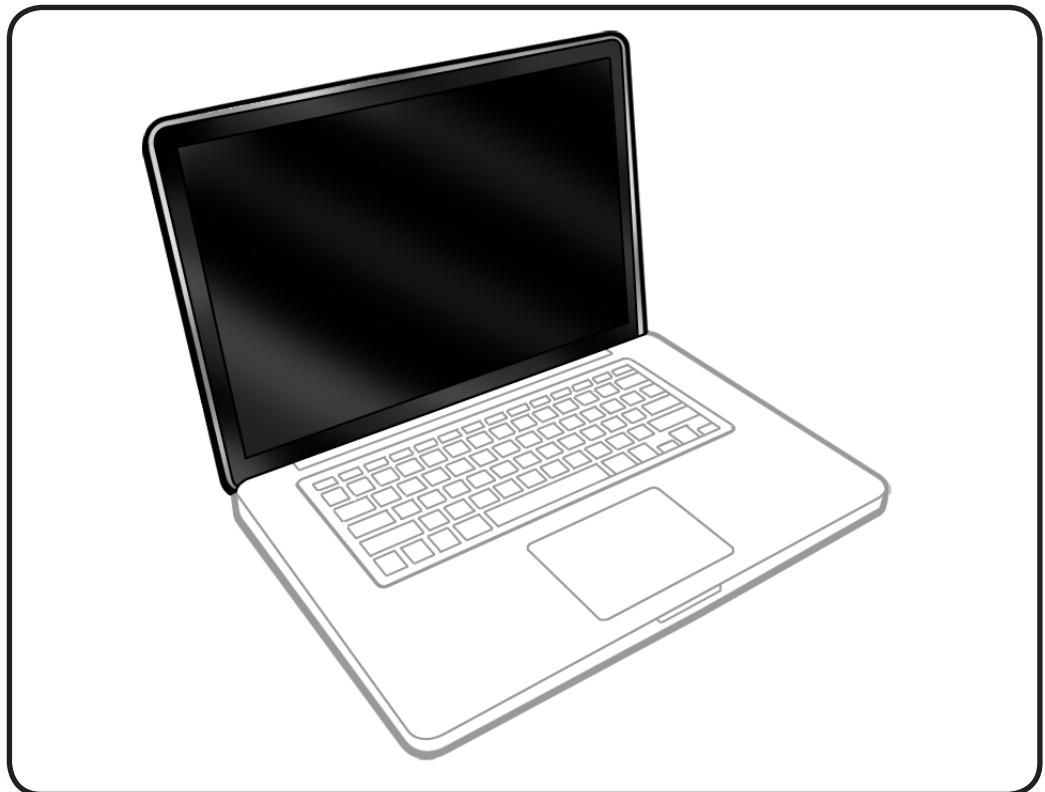



Display Clutch Cover

First Steps

Remove:

- [Access door](#)
- [Battery](#)
- [Bottom case](#)
- [Camera cable guide](#)
- [LVDS cable guide](#)
- [Display assembly](#)

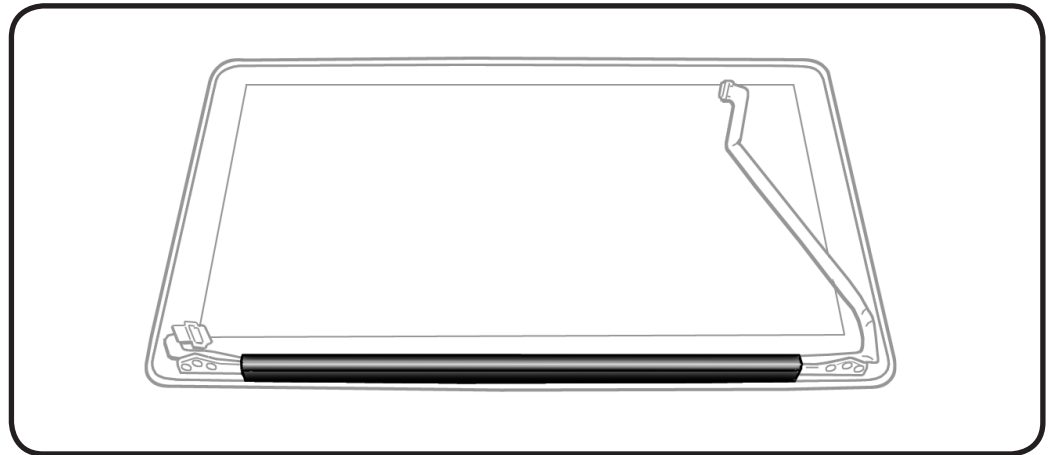

Tools

- Clean, soft, lint-free cloth
- ESD wrist strap and mat

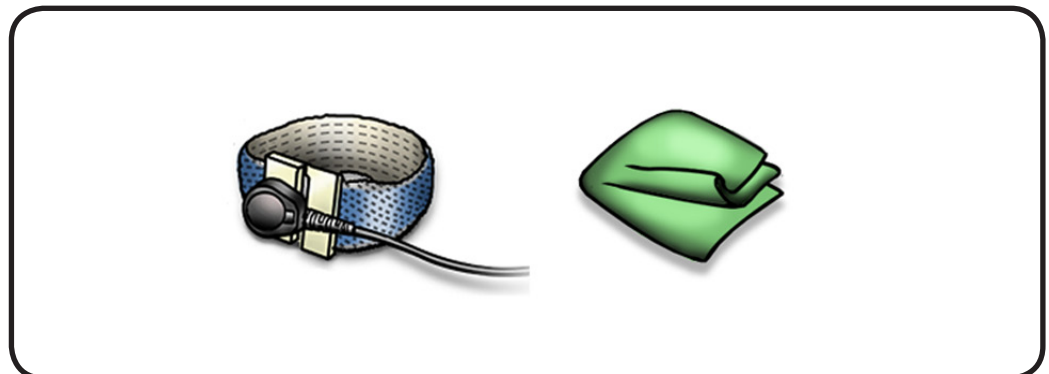



Removal

- 1 Cover display face with clean, soft cloth.

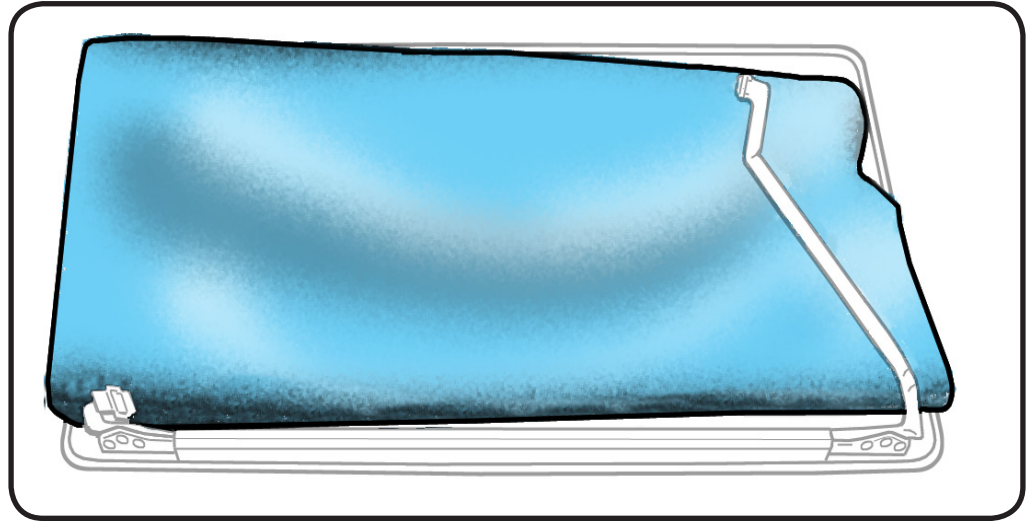

- 2 Holding left hinge, slide clutch cover 1/4 inch (6.35 mm) away from the LVDS cable.

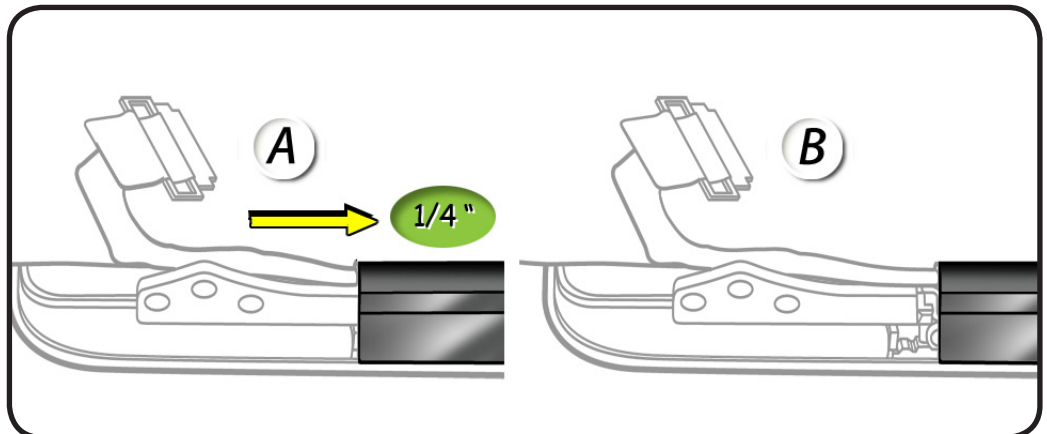

- 3 Press down on clutch cover to loosen 4 hooks inside.

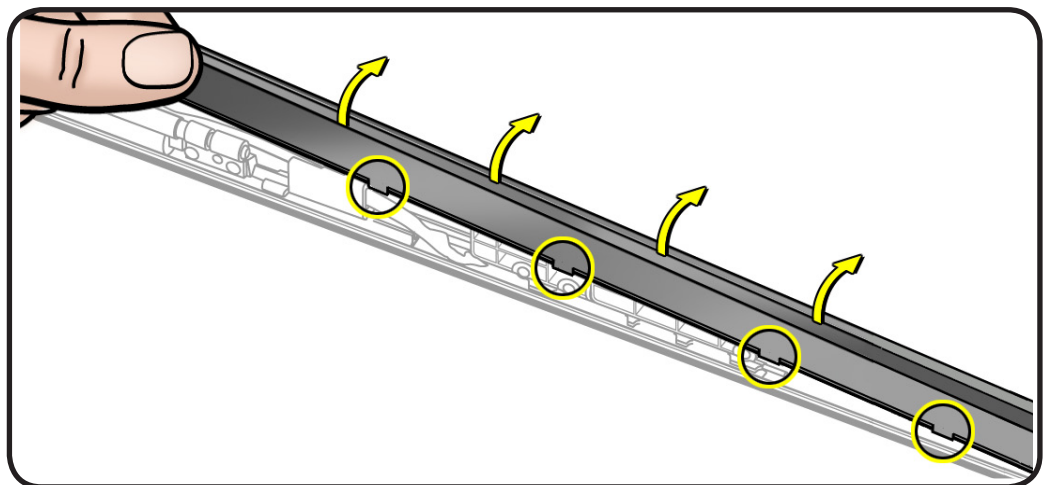



- 4 Tilt up end of clutch cover as you roll it toward display face.
- 5 Remove clutch cover.

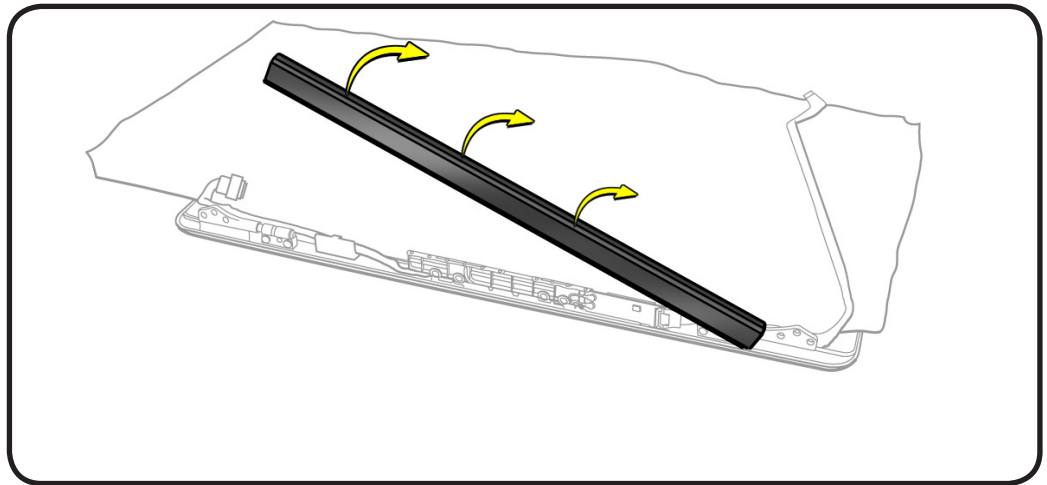

Replacement

- 1 Note shape of clutch cover:
 - flat at bottom
 - curved at top
- 2 Make sure flat edge is at bottom of display.

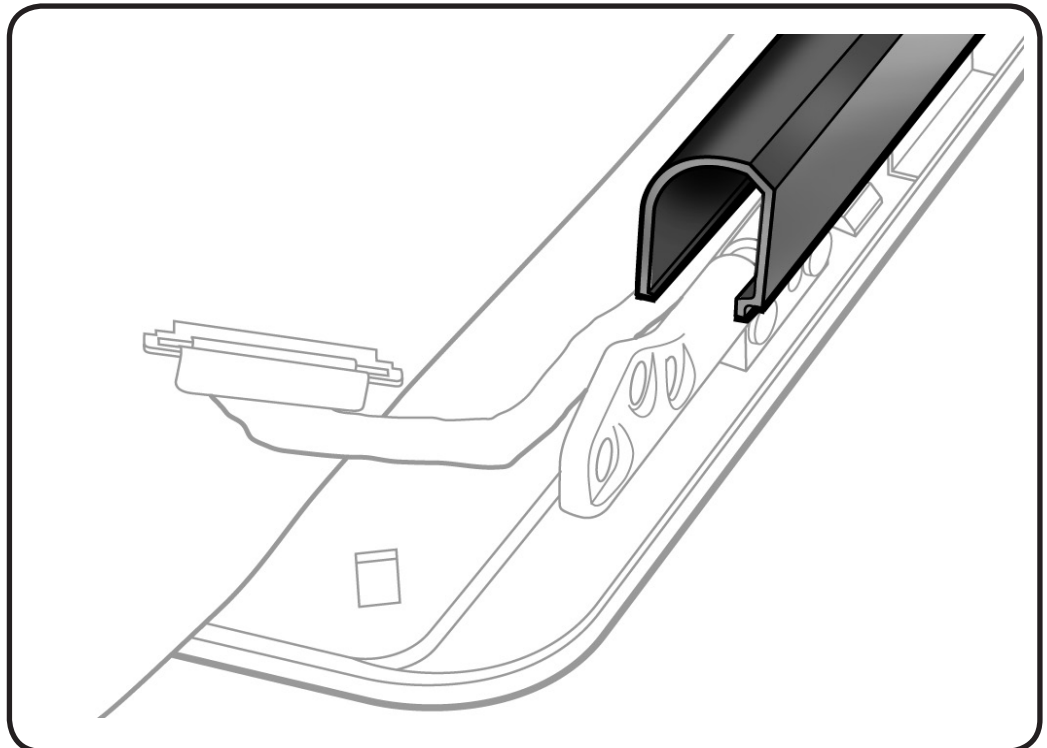



- 3** Position clutch cover onto end with longer cable.
- 4** Lower clutch cover onto display assembly.
- 5** Listen for snapping sound as hooks engage.
- 6** Check for good fit.
Avoid:
 - gaps
 - bulges
 - pinched cables

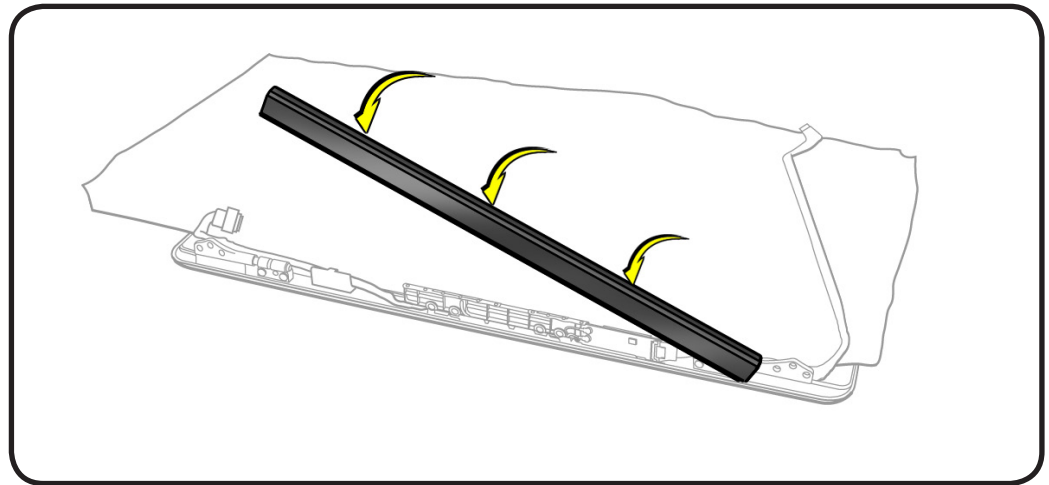



AirPort Card

First Steps

Remove:

- [Access door](#)
- [Battery](#)
- [Bottom case](#)
- [Camera cable guide](#)
- [LVDS cable guide](#)
- [Display assembly](#)
- [Display clutch cover](#)

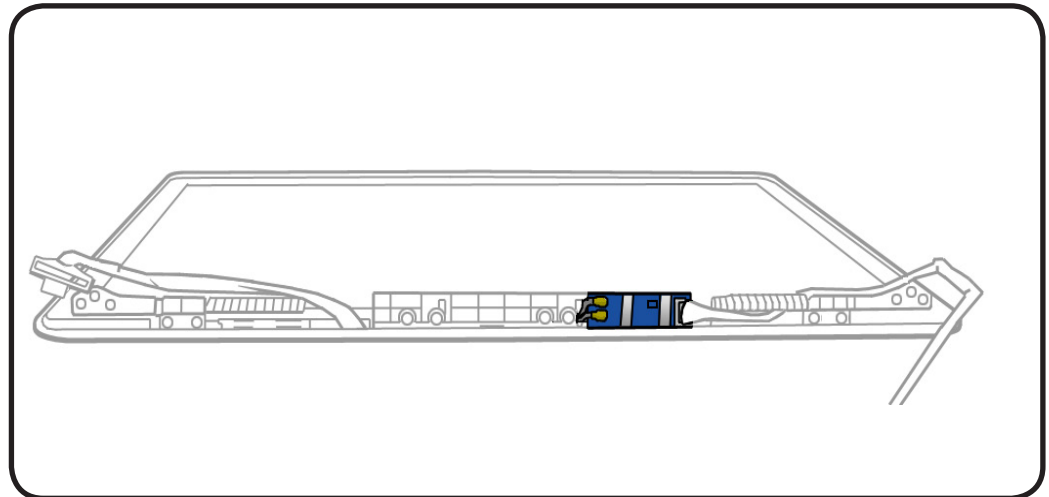

Tools

- Clean, soft, lint-free cloth
- ESD wrist strap and mat
- Black stick
- Phillips #00 screwdriver

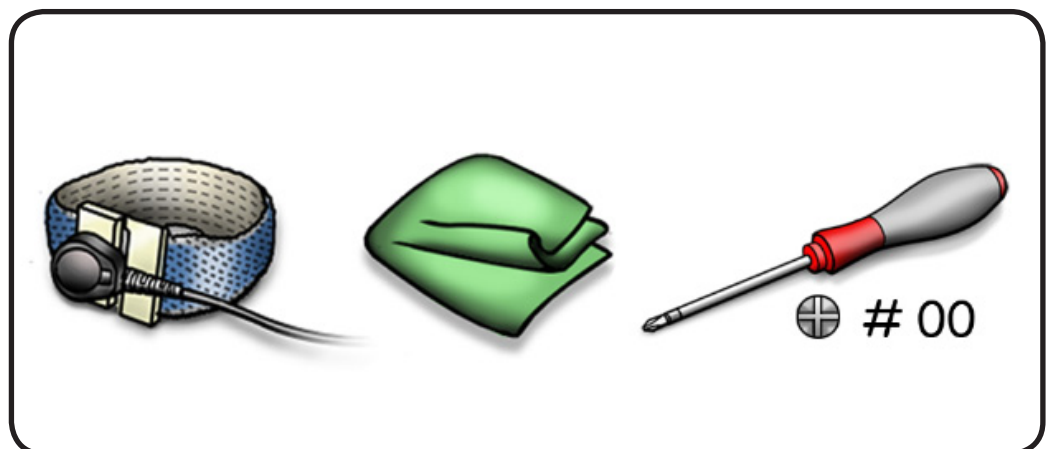



Removal

- 1 Cover display with clean, soft cloth.
- 2 Remove 3-mm screw (076-1327) from cable clip.

Note the wide head on this screw.

- 3 Lift up cable clip.

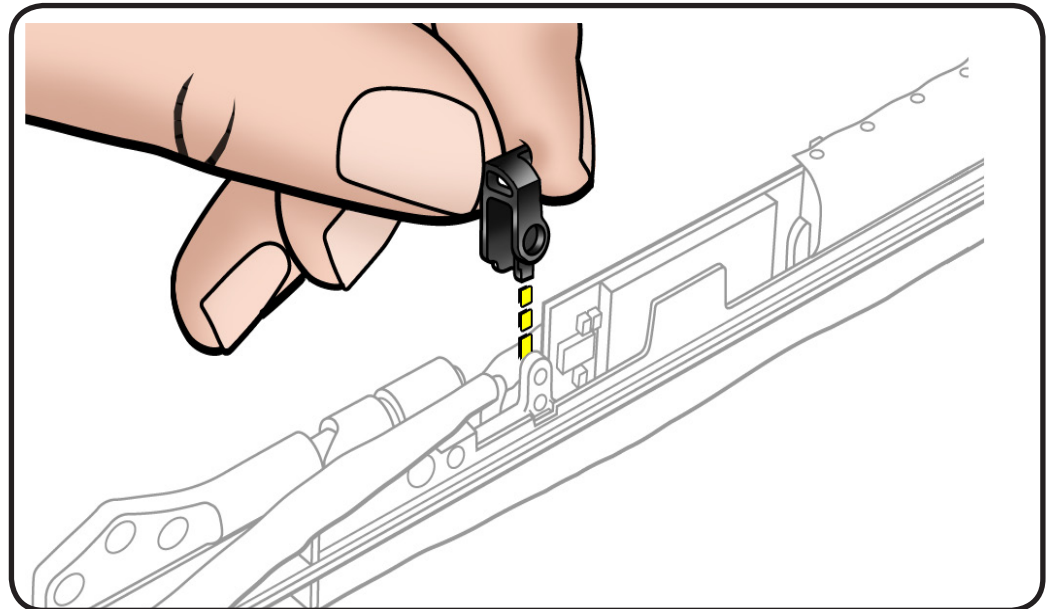
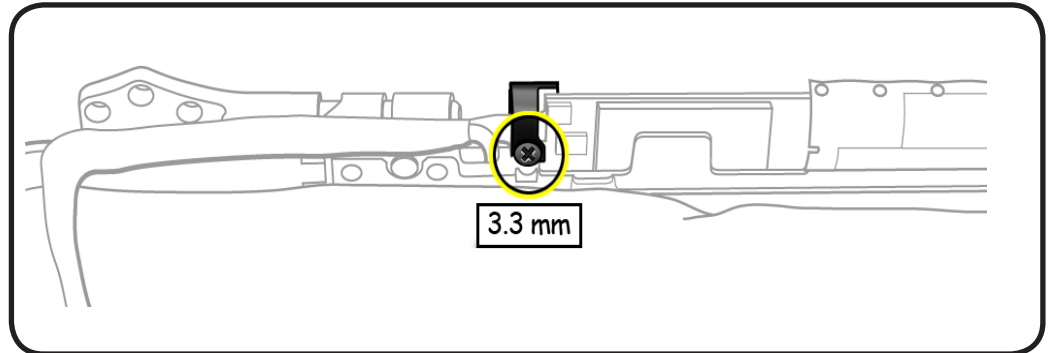

- 4 Disconnect AirPort cable.

- 5 Disconnect 2 AirPort antenna cables using a black stick.

Replacement Note:
Shorter antenna is at bottom.

- 6 Remove 2 (3-mm) screws (076-1327).

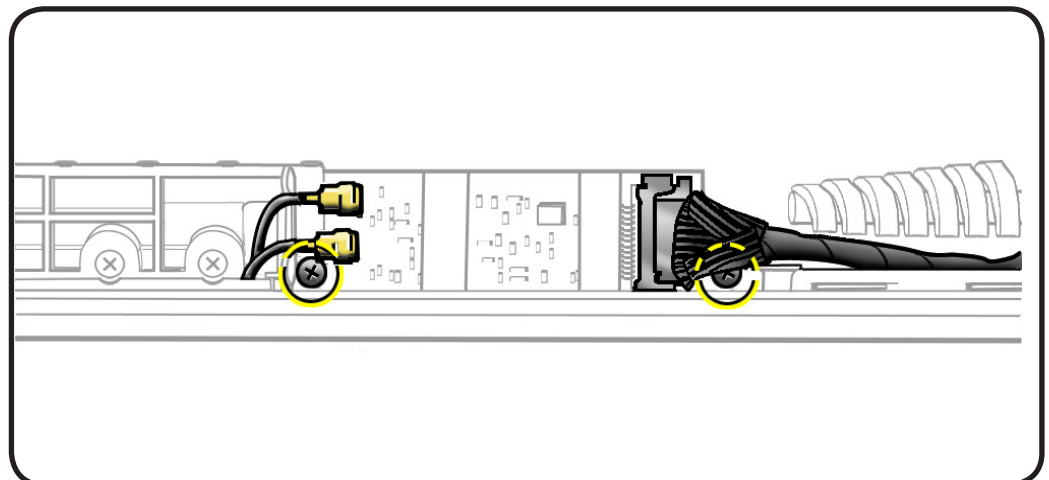



7 Remove 2 (6.7-mm) screws (076-1327) from the cable clip.

8 Lift out AirPort Card.

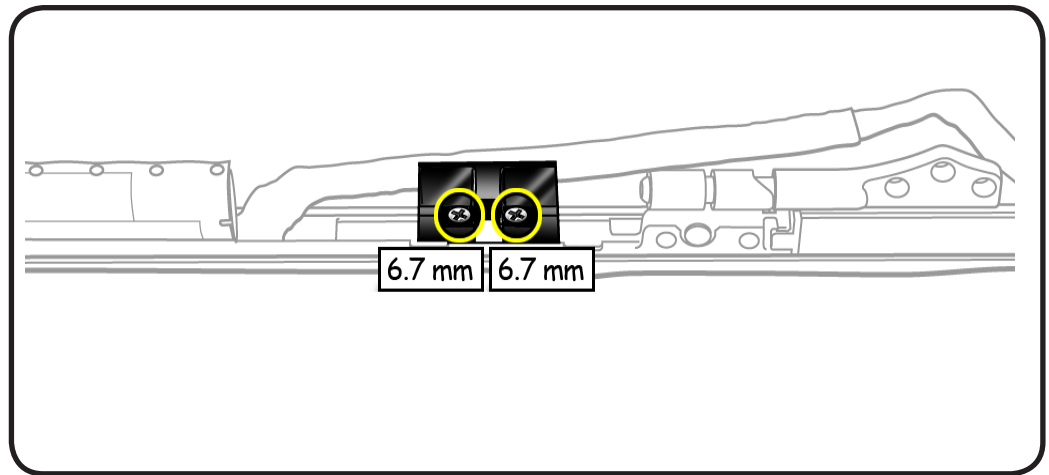

Replacement

1 Make sure thermal pad is centered on AirPort Card rather than stuck to display assembly tab.

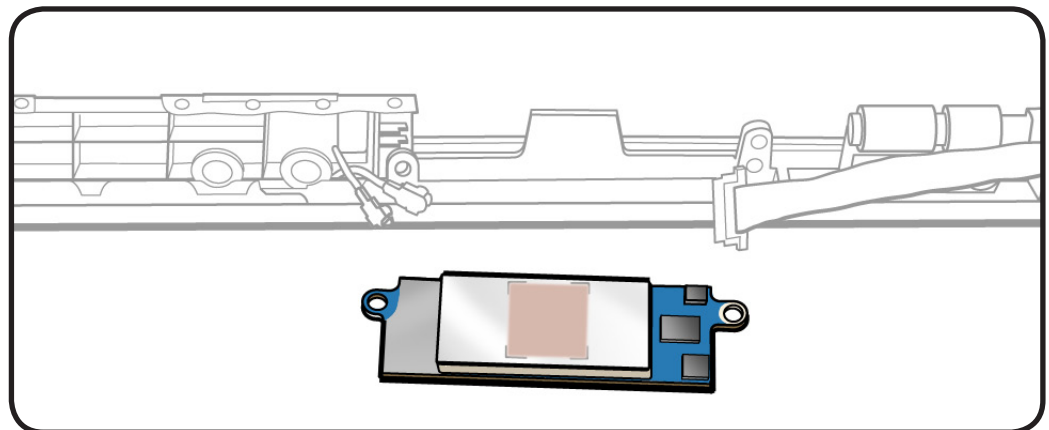

2 Connect AirPort cable and 2 AirPort antenna cables. Replace screws.

Important: Make sure the AirPort cable is installed correctly, refer to the next step for more information.

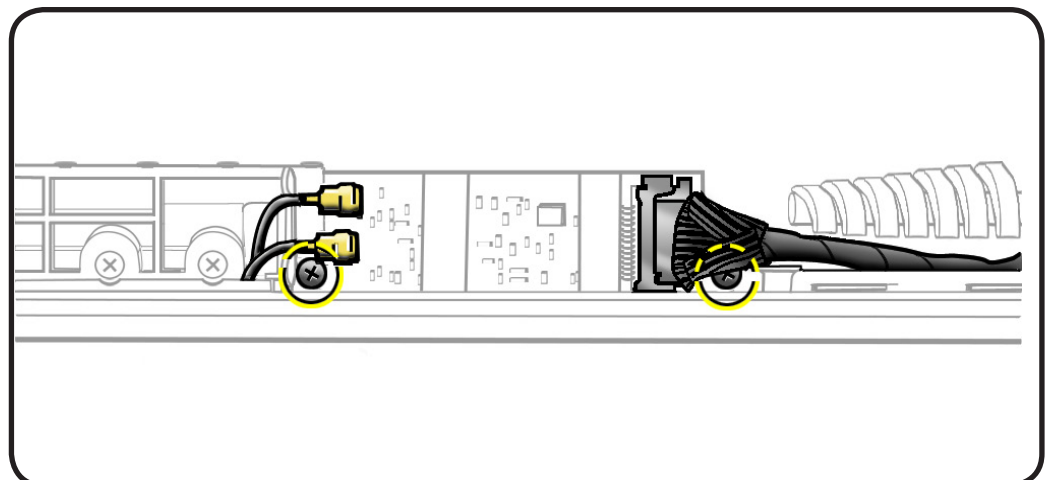



- 3 Important:** Check the orientation of the AirPort cable before inserting it into the AirPort card connector.

At the end of the cable, on the metal part, there are two grounding fingers (two U-shaped marks). Orient the grounding fingers so they are facing the AirPort card and are in contact with the AirPort card connector. The grounding fingers should **NOT** be facing you. Inserting the cable incorrectly will cause logic board failure!

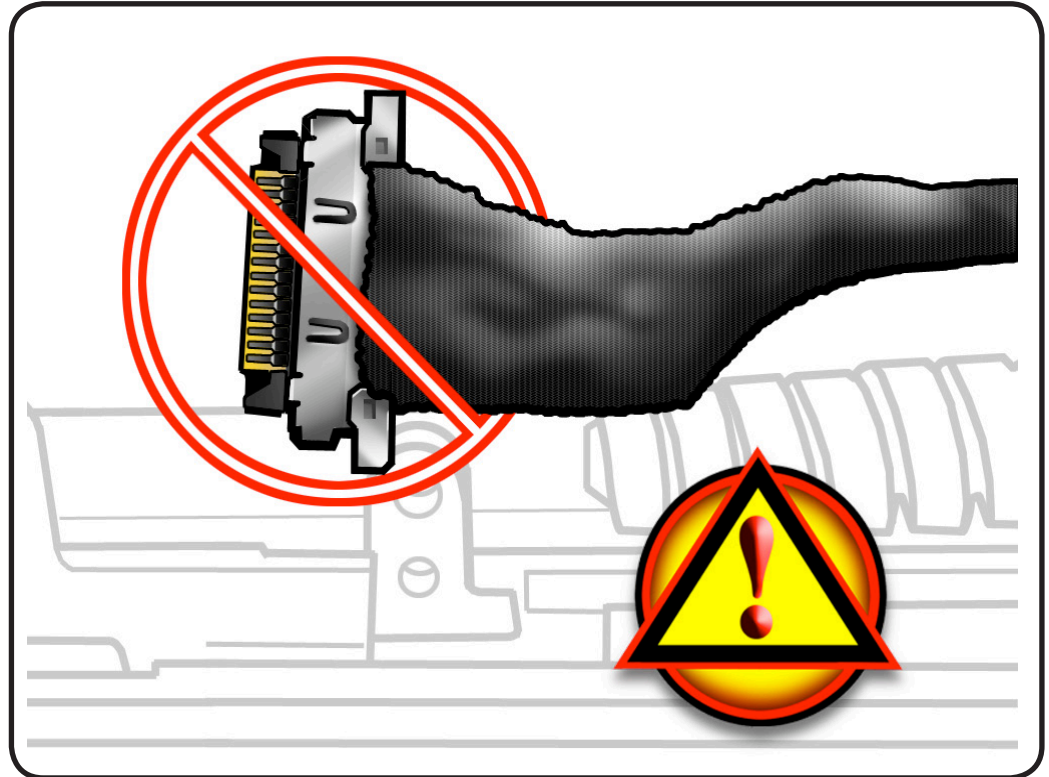

- 4** Route the other end of cable (with LVDS connector) under the other clip.
- 5** Replace 2 screws on clip.

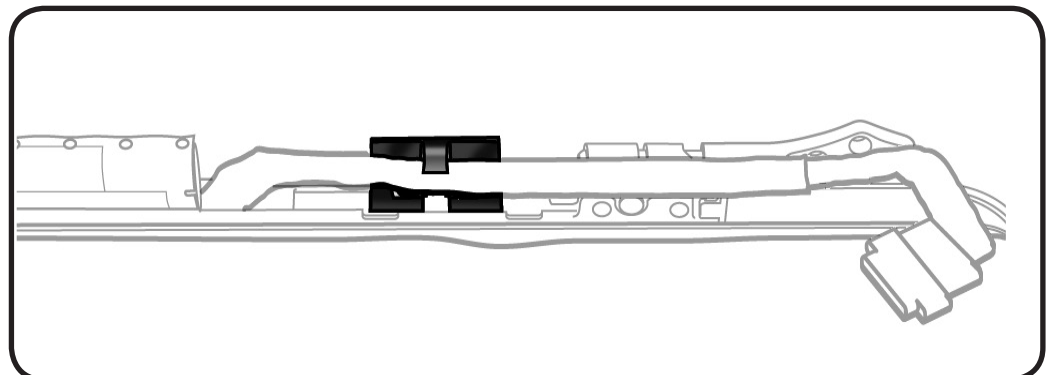



6 Replace clutch cover.

7 Reassemble computer.



Caution: When testing an AirPort card connection, wait at least 5 seconds after shutdown before connecting the camera cable connection to the logic board. Waiting less than that could damage the AirPort card.

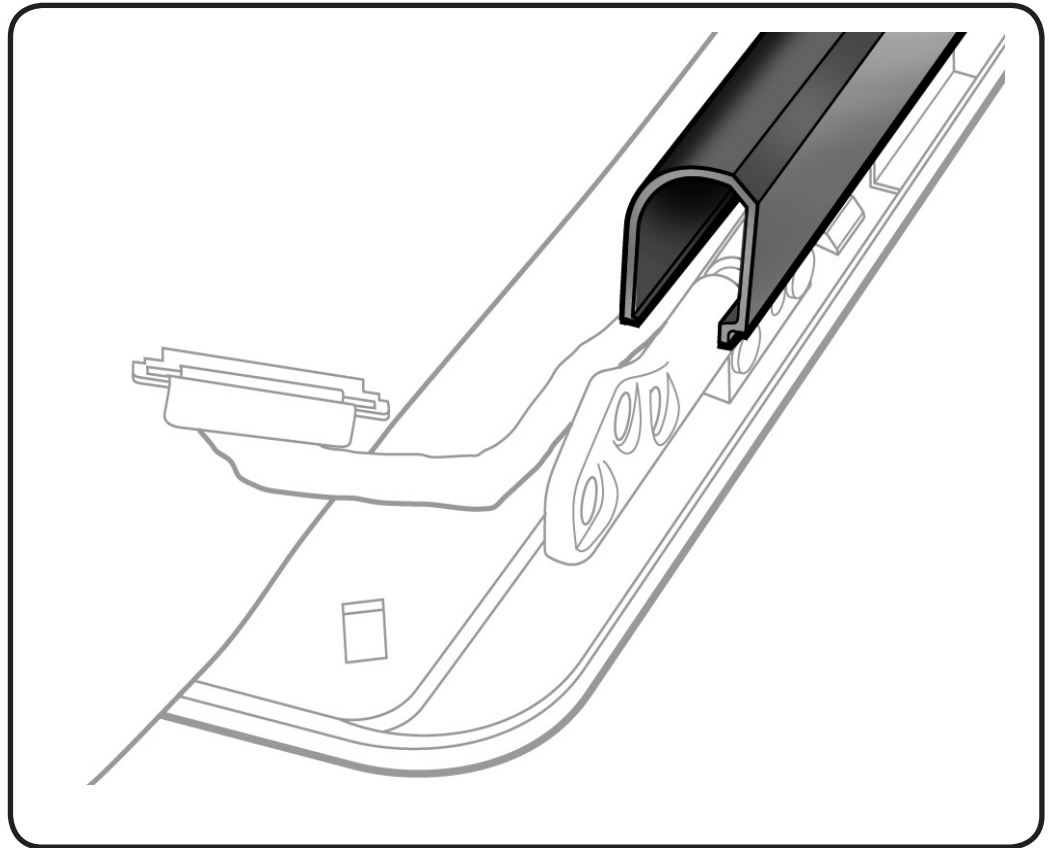



Antenna Board

First Steps

Remove:

- [Access door](#)
- [Battery](#)
- [Bottom case](#)
- [Camera cable guide](#)
- [LVDS cable guide](#)
- [Display assembly](#)
- [Display clutch cover](#)

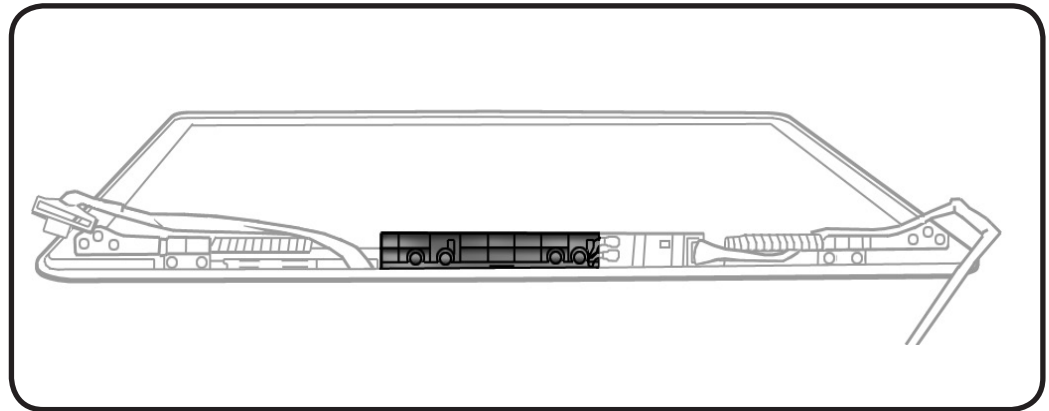

Tools

- Clean, soft, lint-free cloth
- ESD wrist strap and mat
- Black stick
- Phillips #00 screwdriver

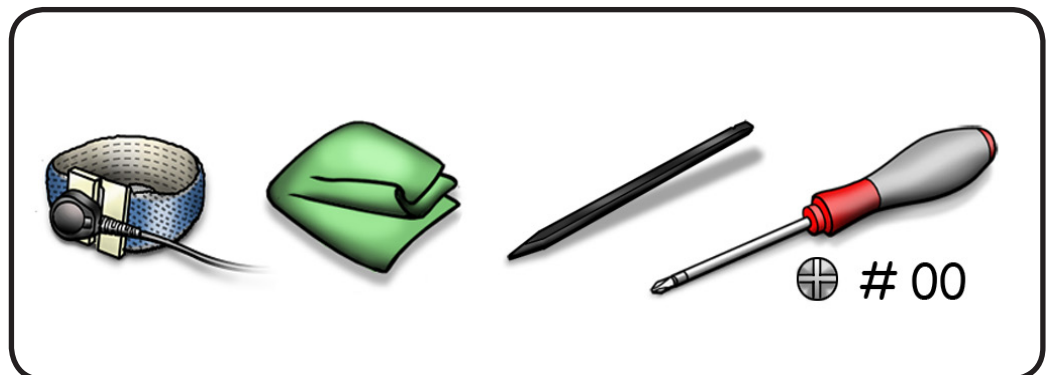



Removal

- 1 Disconnect antenna connectors using a black stick.
- 2 Remove 4 (3-mm) screws (076-1326).
- 3 Lift out antenna board.

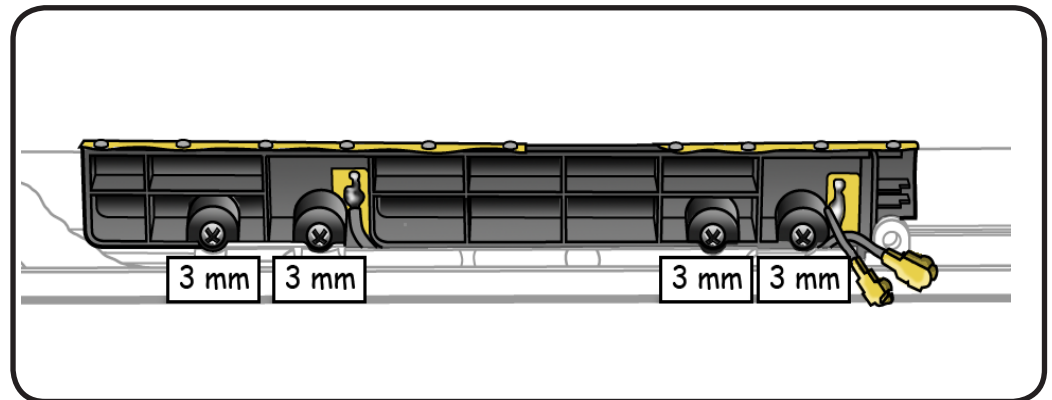

Replacement

- 1 Make sure the AirPort antenna cable is routed in its channel.
- 2 Make sure end of each antenna connector is secured in its channel.
- 3 Set the antenna board in the display assembly and install the screws.
- 4 Connect the antennas to the AirPort card.

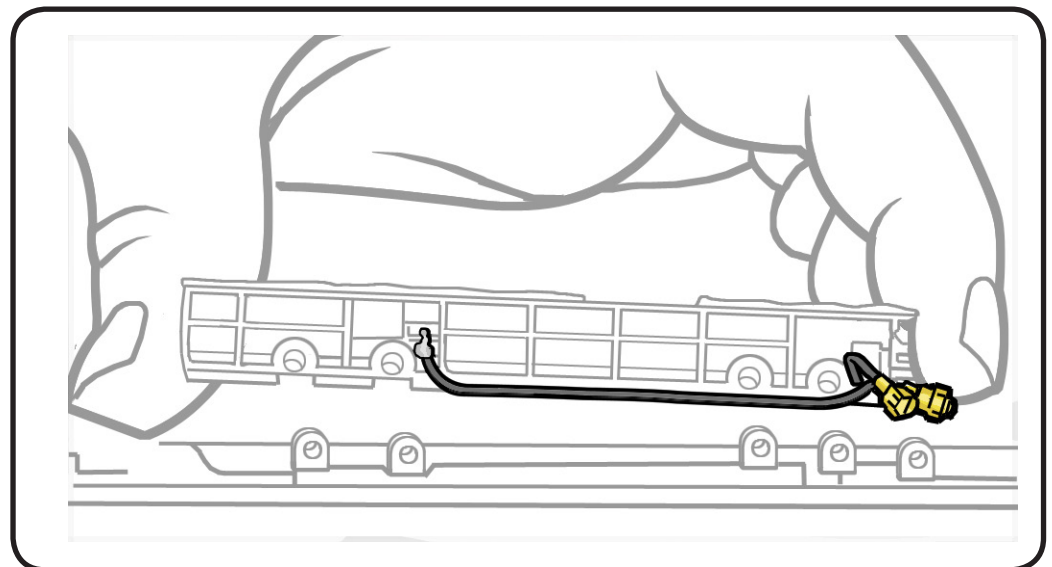



Optical Drive

First Steps

Remove:

- [Access door](#)
- [Battery](#)
- [Bottom case](#)
- [Camera cable guide](#)



Caution: The optical drive is very fragile. Handle by the sides only.

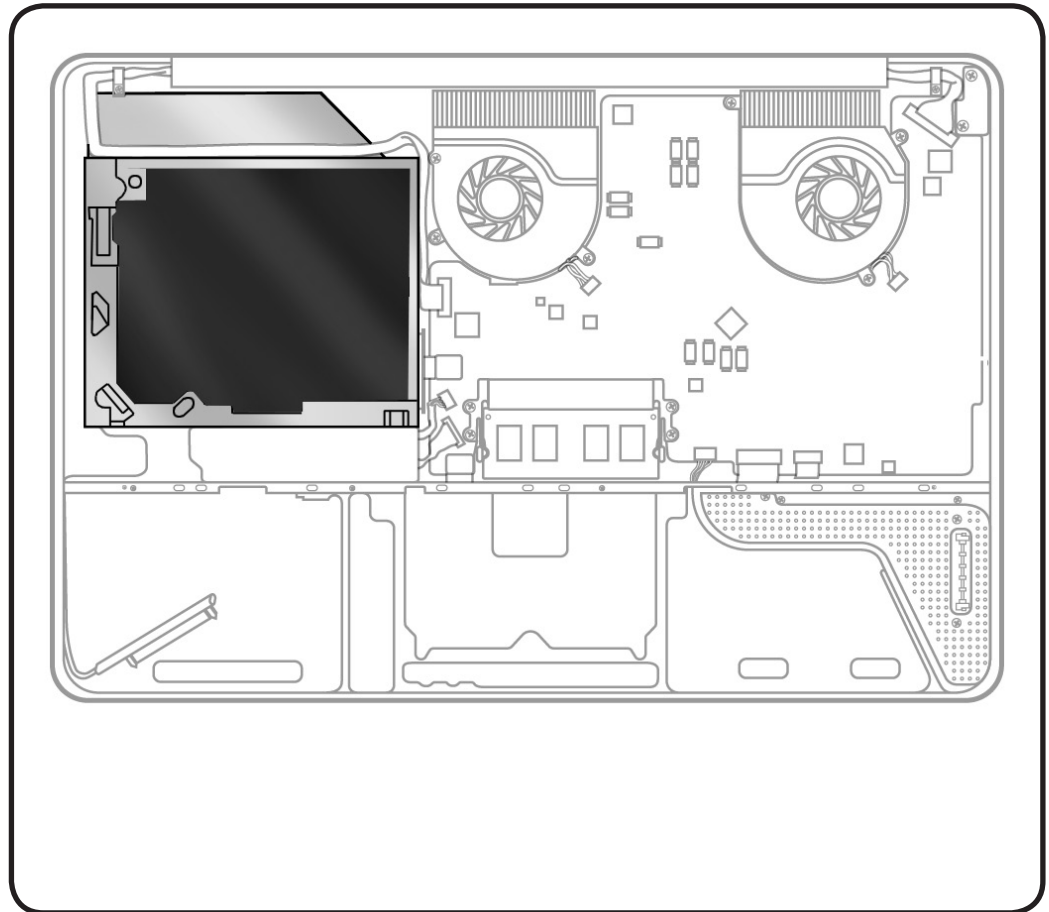

Tools

- Clean, soft, lint-free cloth
- ESD wrist strap and mat
- Magnetized Phillips #00 screwdriver
- Black stick

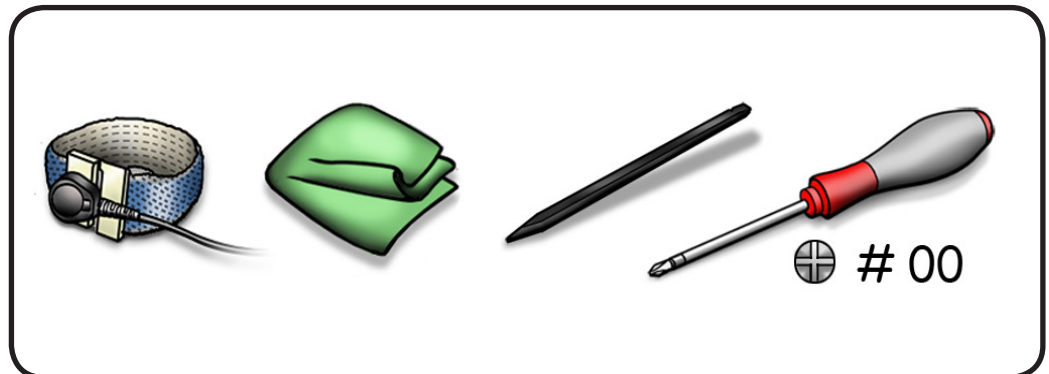



Removal

- 1 Locate camera/AirPort/Bluetooth/connector and black shim on the logic board.
- 2 Using a black stick, pry the shim from the logic board and set it aside. If you don't remove the shim prior to removing the cable, you could damage the logic board and/or the camera cable.

Important: Be sure to replace the shim after you reconnect the cable. Otherwise, the cable could work loose, resulting in no video.

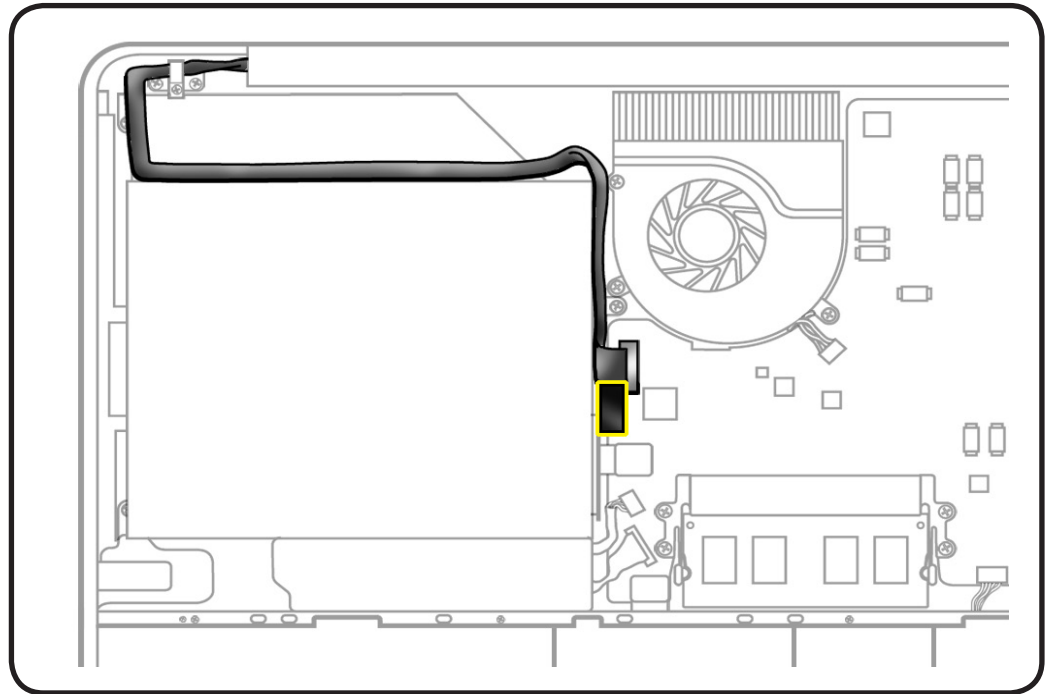

- 3 Peel EMI gasket off top of the camera cable (A)
- 4 Disconnect camera cable from logic board (B).

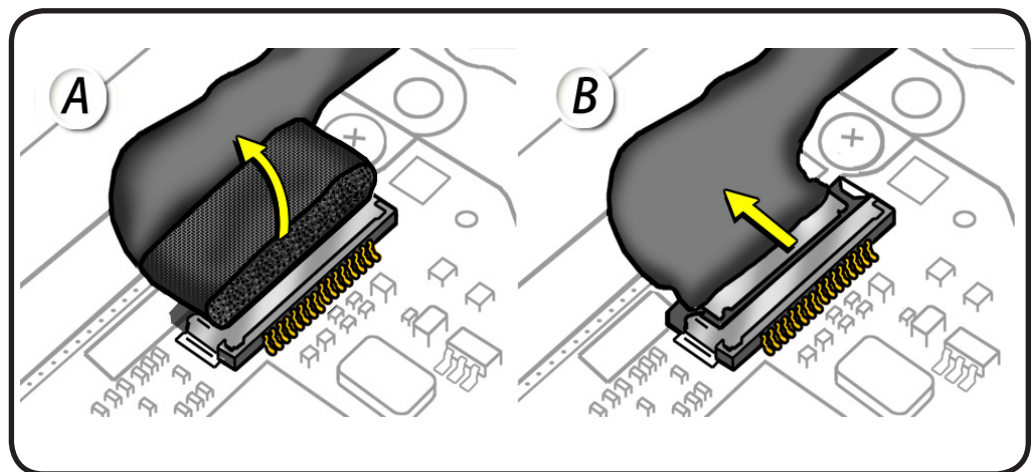



- 5 With a black stick, carefully pry optical cable straight up and off logic board.



Important

Replacement Note:

Install flex cable vertically onto logic board connector. Failure to do so could bend logic board pins and cause the system to not detect a disc when inserted.

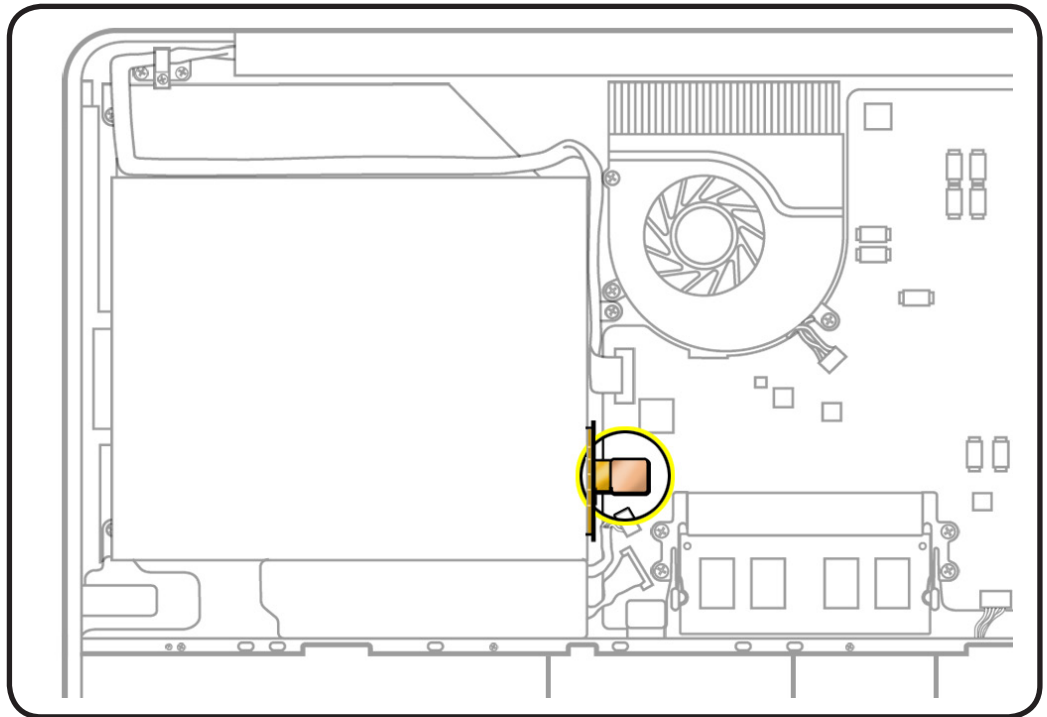

- 6 Remove 3 screws:
- 1 (3.5-mm), screw not offered yet
 - 2 (2.5-mm) 922-8719

- 7 Carefully lift the optical drive out of the top case.

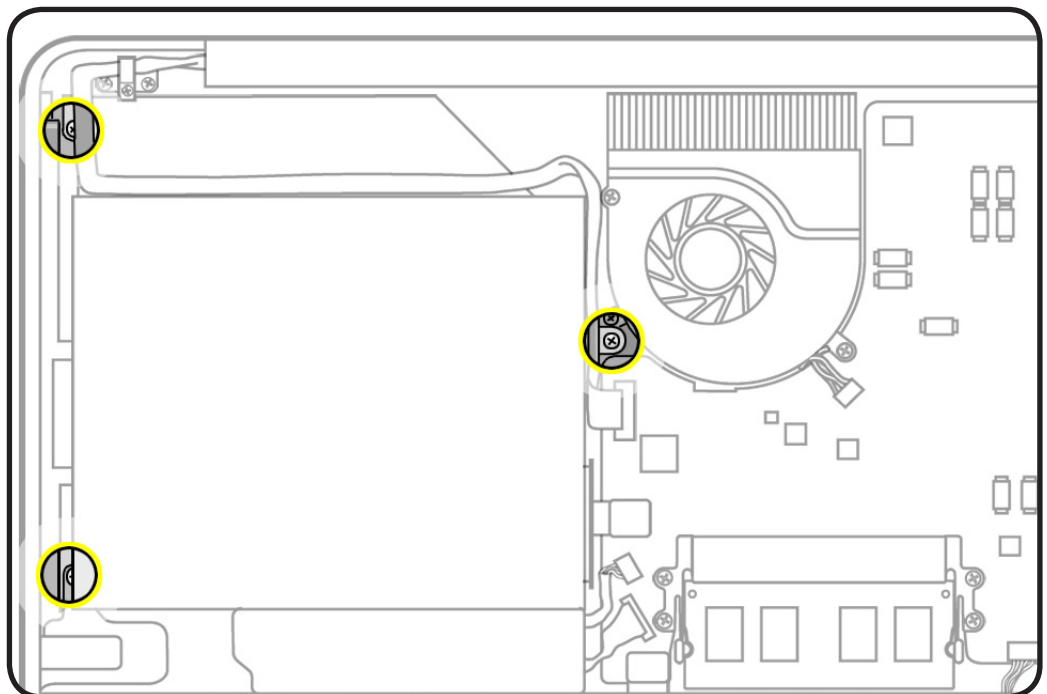



- 8 Caution:** The optical drive is very fragile. Handle by the sides only!

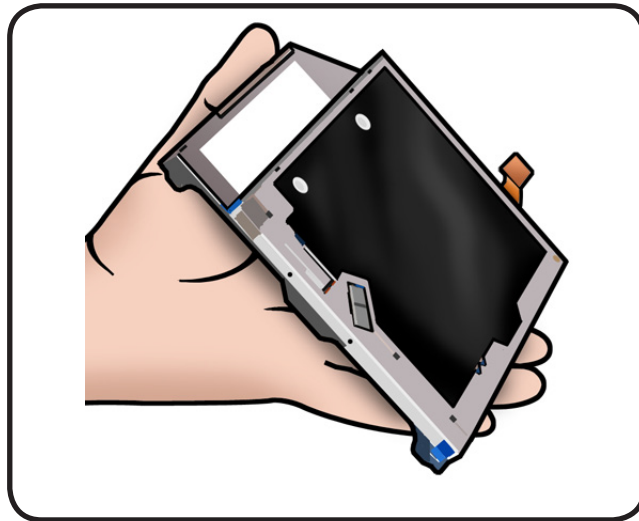

Replacement

- 1** When connecting the camera/AirPort/Bluetooth cable, make sure the cable is fully connected.
- 2** Replace the shim after you reconnect the cable. Otherwise, the cable could work loose, resulting in no video.
- 3** Replace the EMI gasket on top of the connector.

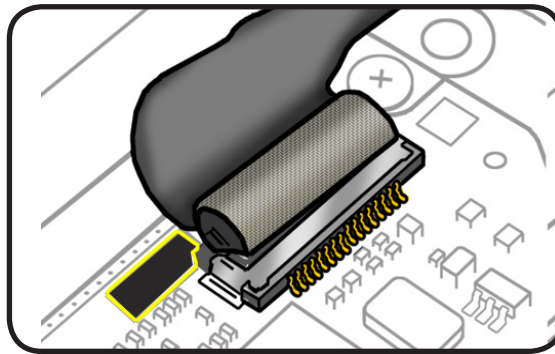



Optical Drive Flex Cable

First Steps

Remove:

- [Access door](#)
- [Battery](#)
- [Bottom case](#)
- [Camera cable guide](#)
- [Optical drive](#)

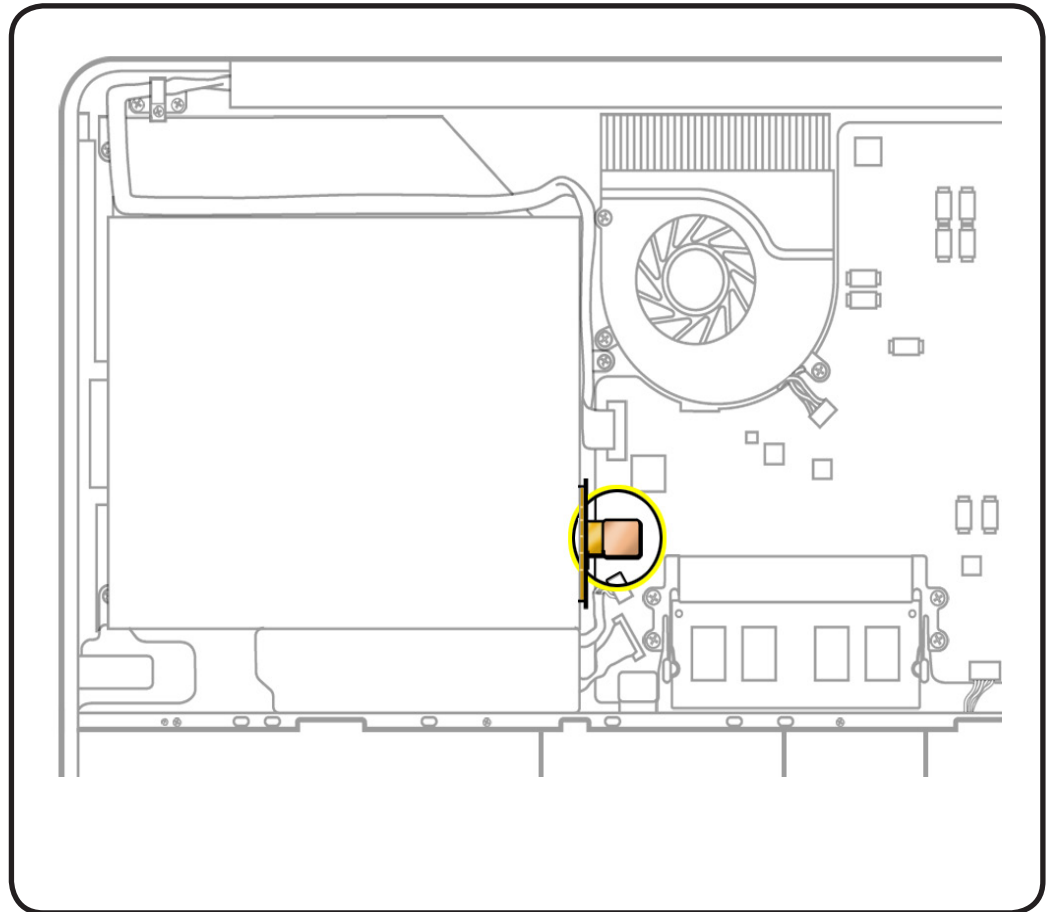

Tools

- Clean, soft, lint-free cloth
- ESD wrist strap and mat
- Black stick

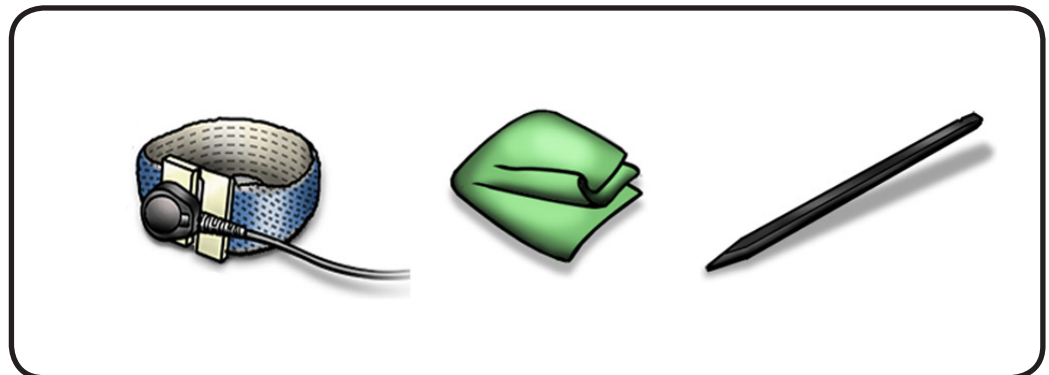



Removal

- 1 Handle optical drive by sides only.
- 2 With a black stick or fingernail, carefully wiggle flex cable off optical drive.

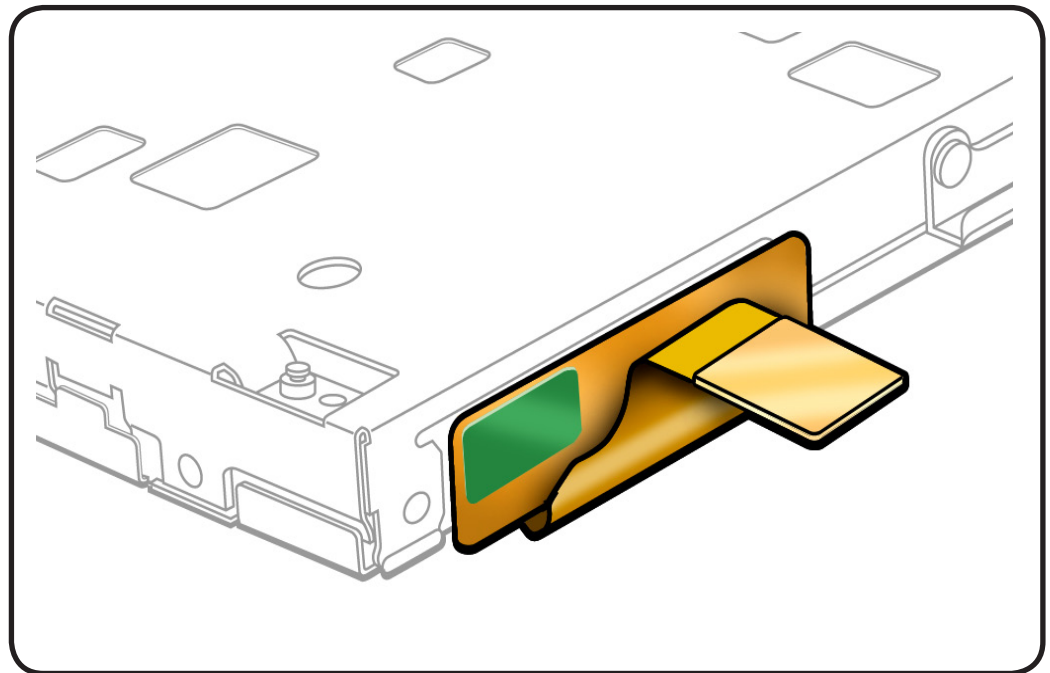



Right Speaker / Subwoofer

First Steps

Remove:

- [Access door](#)
- [Battery](#)
- [Bottom case](#)
- [Camera cable guide](#)
- [Optical drive](#)

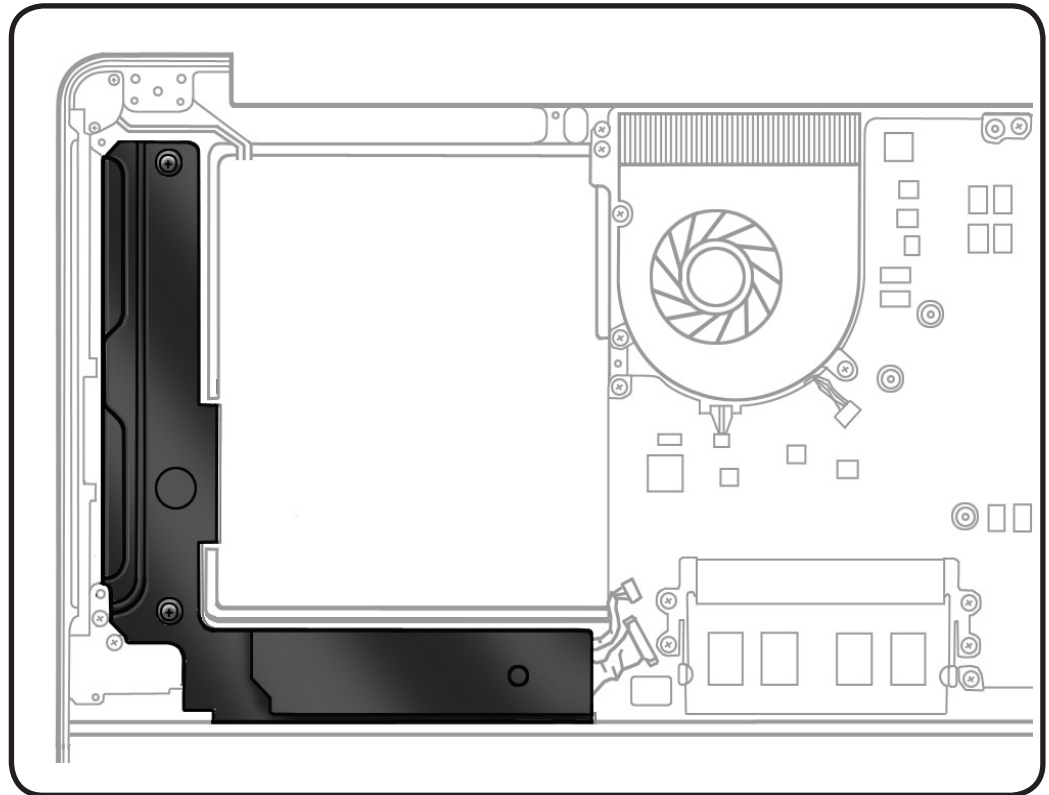

Tools

- Clean, soft, lint-free cloth
- ESD wrist strap and mat
- Black stick
- Magnetized Phillips #00 screwdriver

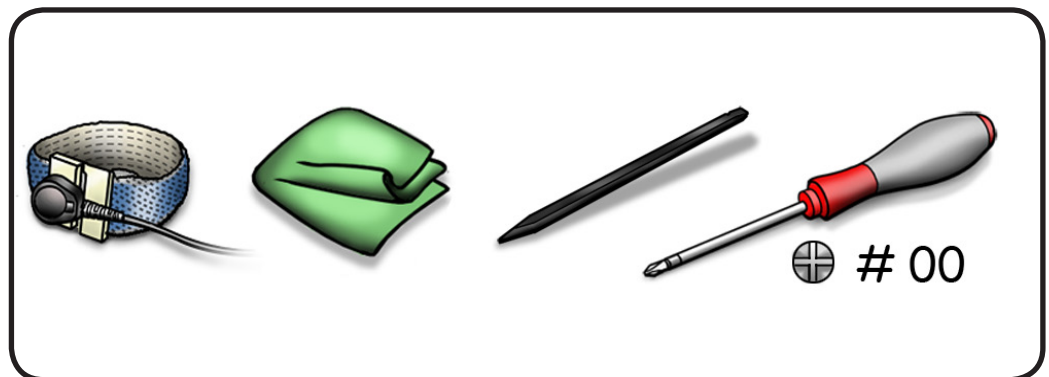



Removal

- 1 Remove 4 screws:
 - 2 (3.2-mm), 922-8744
 - 1 (5.0-mm) 922-9754
 - 1 (2.6-mm), silver, 922-8747

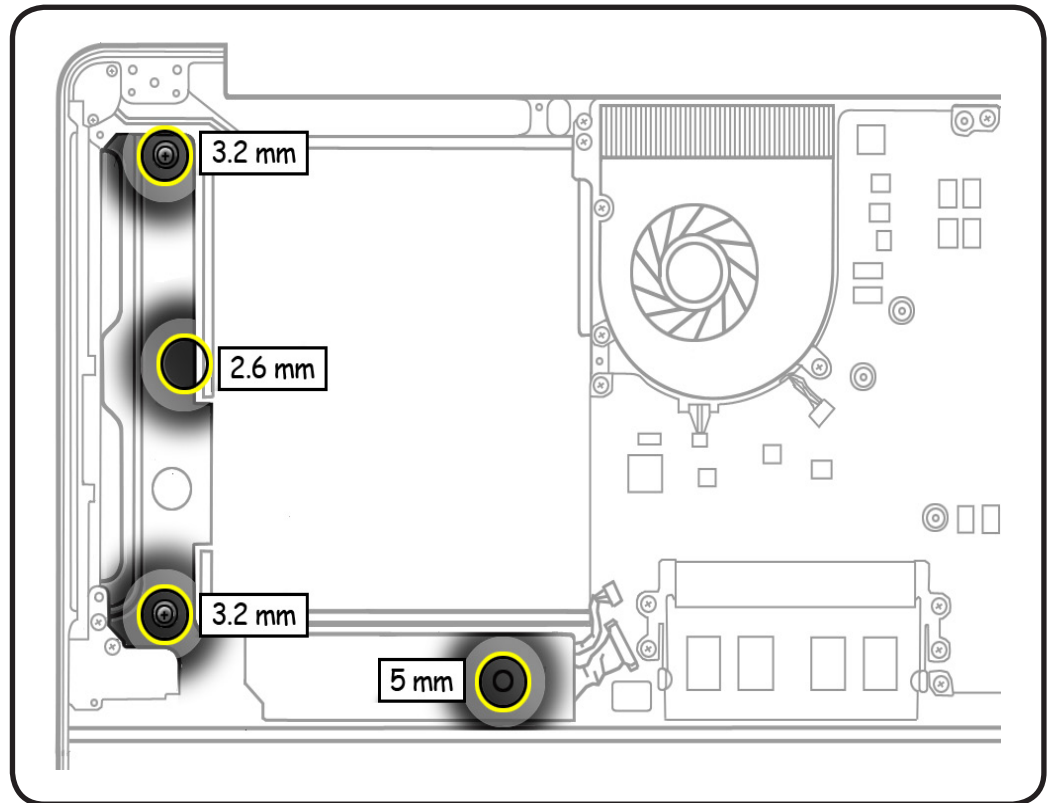

- 2 Disconnect speaker cable on logic board.

- 3 With a black stick, pry up speaker body to loosen adhesive.

Note: Pry around edges, or you will damage subwoofer.

Replacement Note:
If installing a new speaker, peel adhesive backing off speaker and install in top case

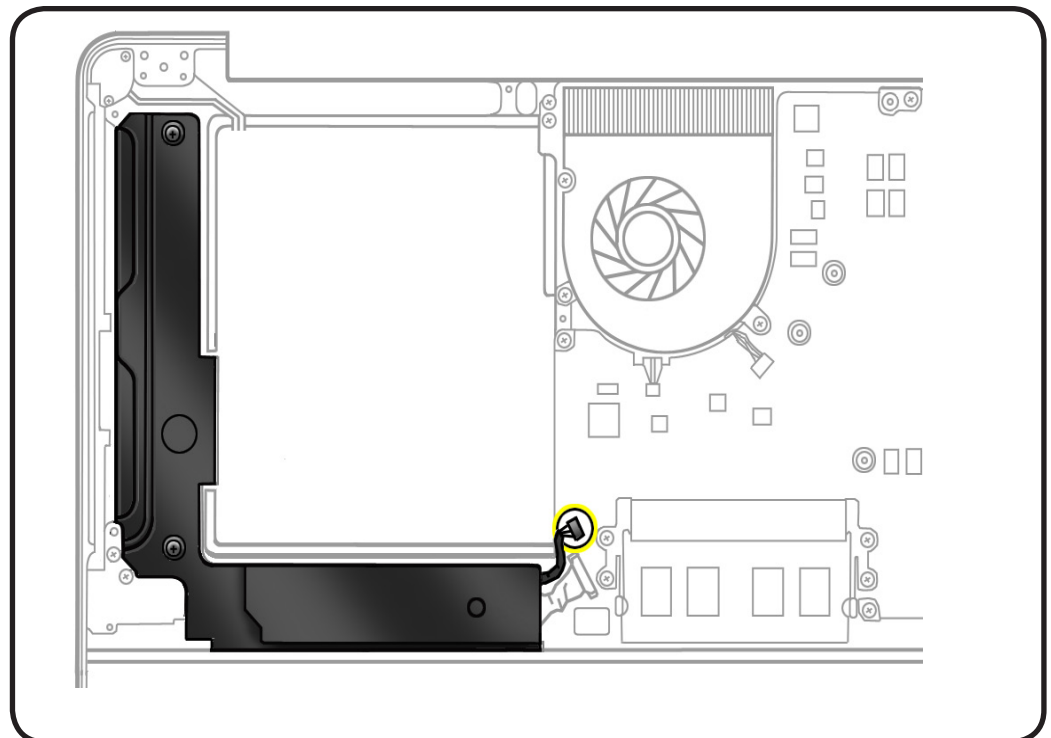



Hard Drive Connector Cable

First Steps

Remove:

- [Access door](#)
- [Battery](#)
- [Bottom case](#)
- [Hard drive](#)
- [Midwall](#)
- [Camera cable guide](#)
- [Optical drive](#)
- [Right speaker/subwoofer](#)

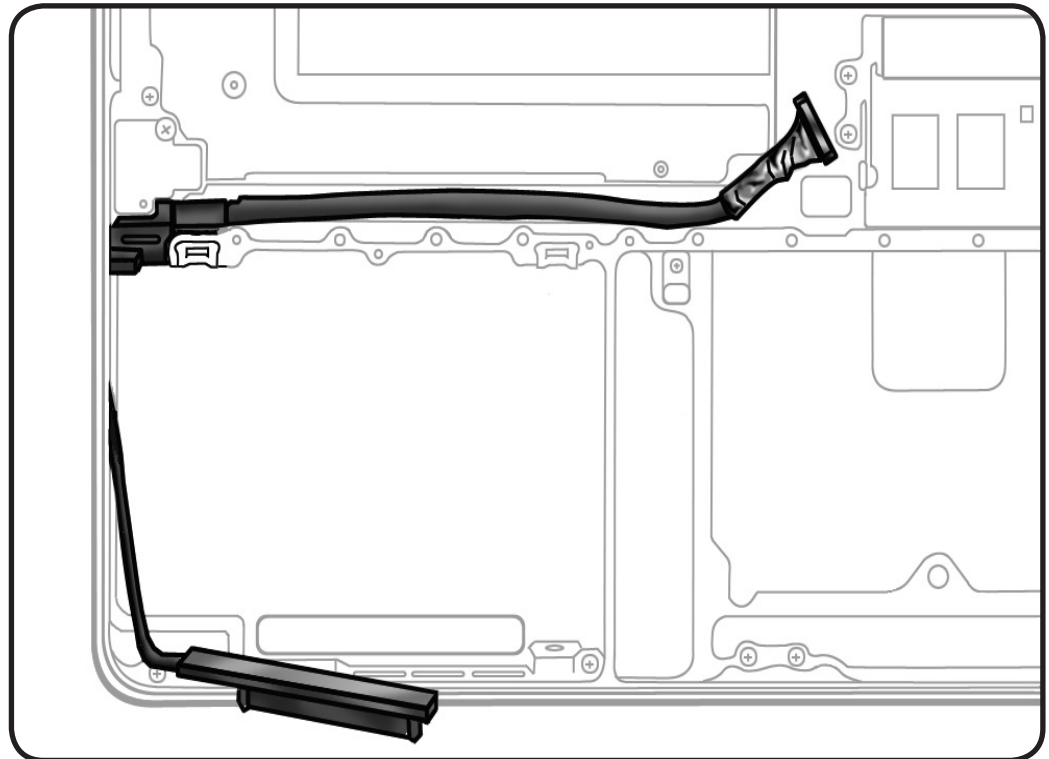

Tools

- Clean, soft, lint-free cloth
- ESD wrist strap and mat
- Black stick
- Magnetized Phillips #00 screwdriver

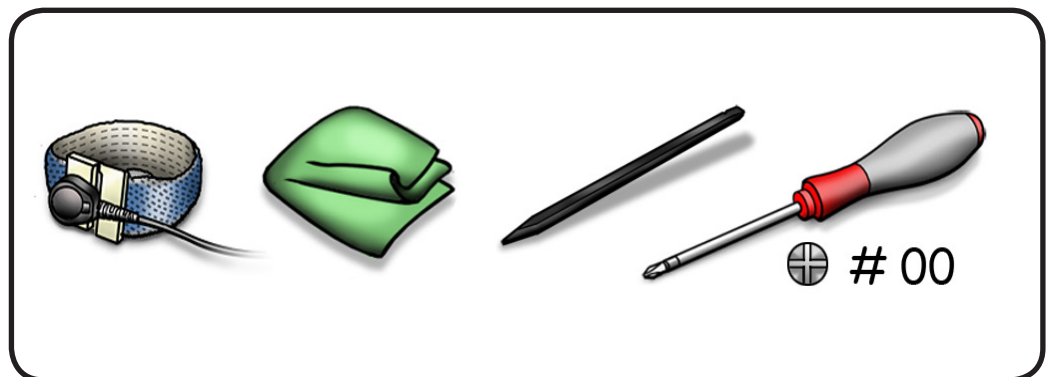



Removal

- 1 Pull straight up on connector on logic board to disconnect cable.

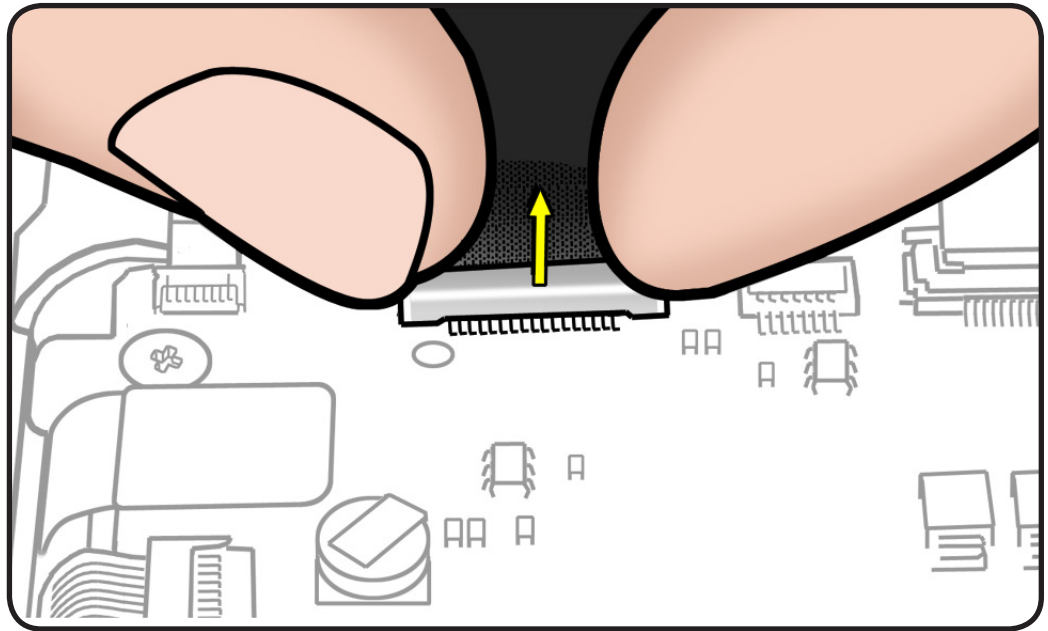

- 2 Peel up cable from top case.

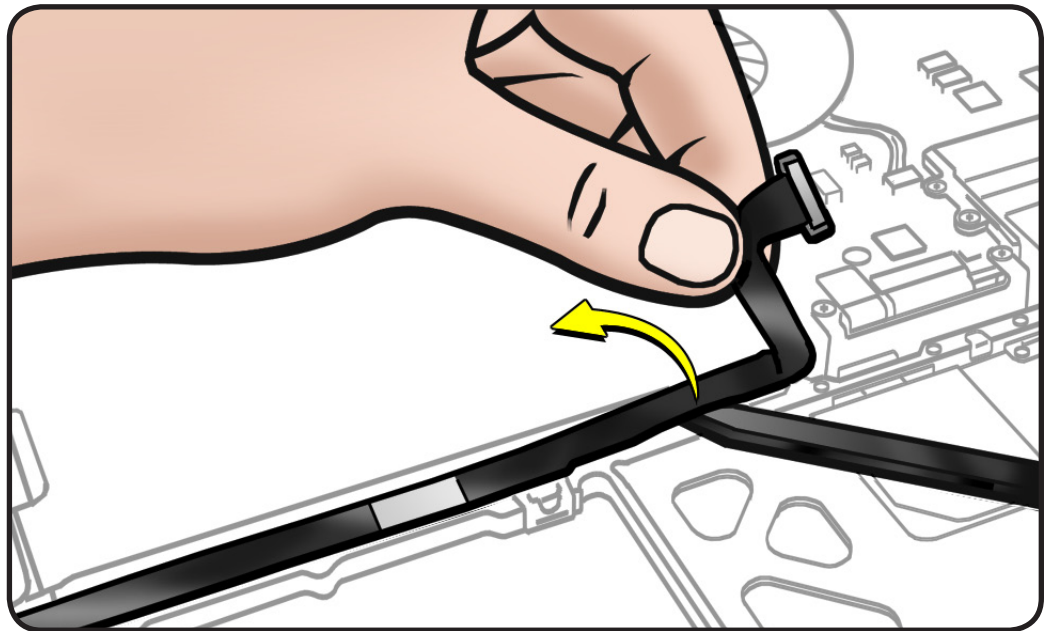



Replacement

- 1** If installing new cable, peel adhesive backing off cable.
- 2** Press cable so it lays flat in top case.
- 3** Connect cable to logic board and hard drive.

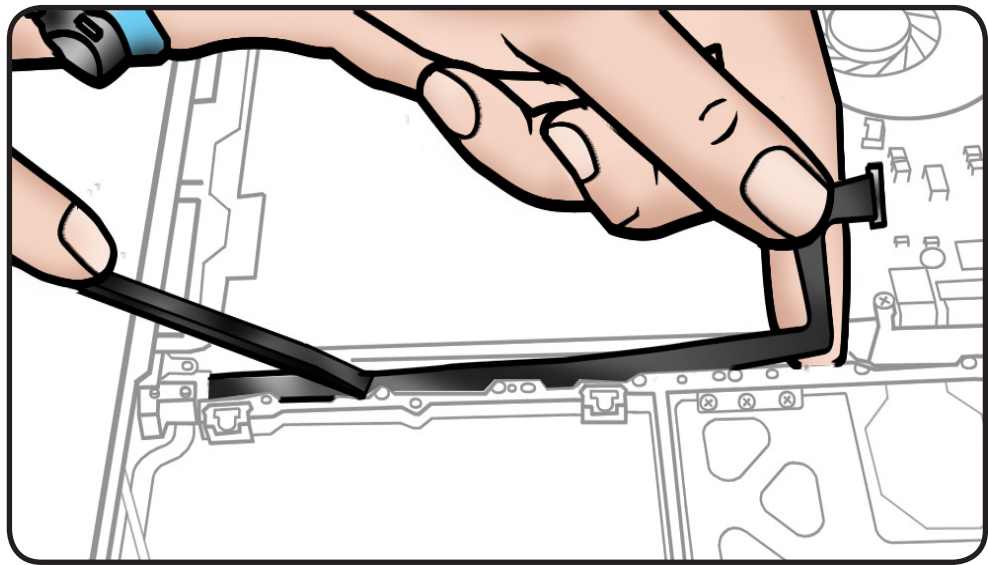



Fans

First Steps

Remove:

- [Access door](#)
- [Battery](#)
- [Bottom case](#)

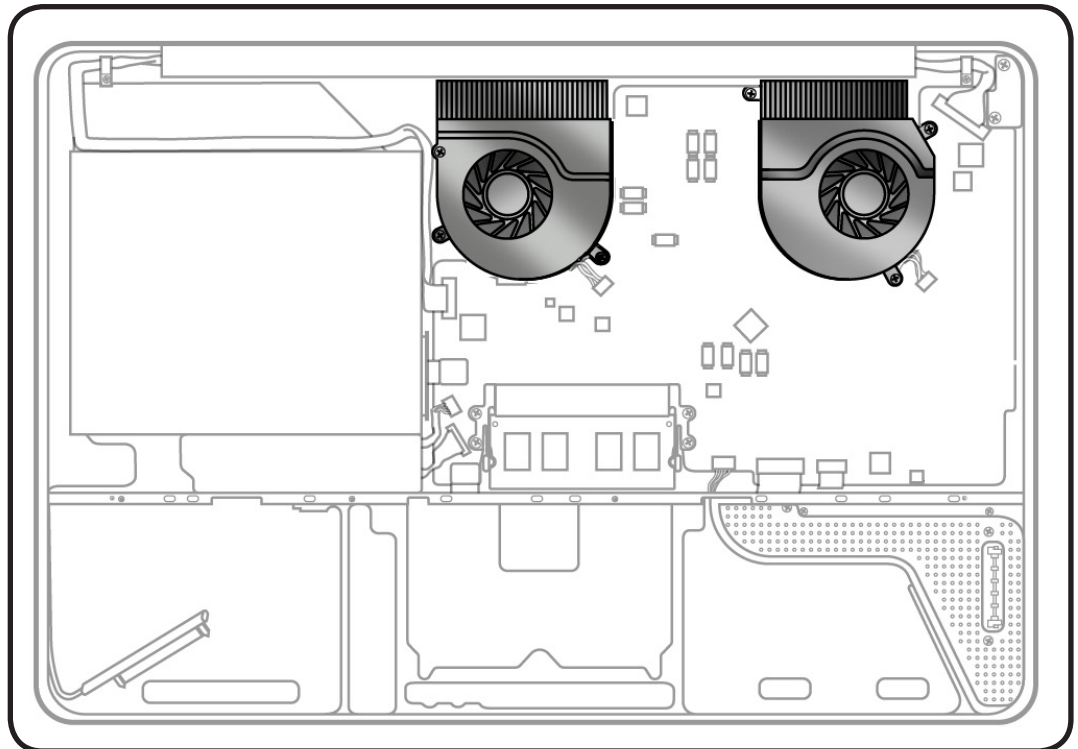

Tools

- Clean, soft, lint-free cloth
- ESD wrist strap and mat
- Magnetized Phillips #00 screwdriver

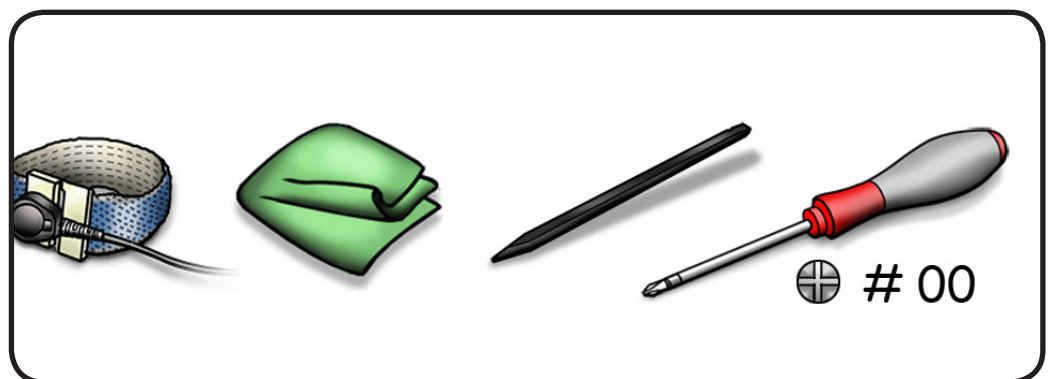



Removal

- 1** Use a black stick to disconnect each fan cable.
- 2** Remove 6 screws:
 - 4 (3.5-mm) 922-8754
 - 2 (3.2-mm) 922-xxxx next to the optical drive. (Screw part not offered yet)
- 3** Lift fans out of top case.

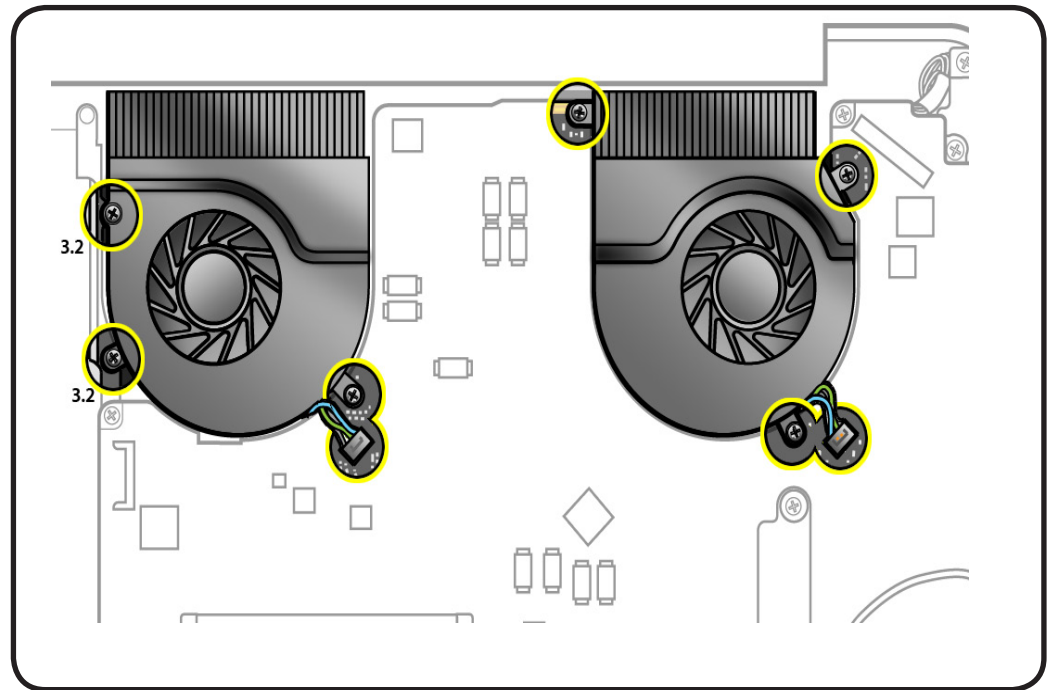



Logic Board



First Steps

Remove:

- [Access door](#)
- [Battery](#)
- [Bottom case](#)
- [Fans](#)
- [LVDS cable guide](#)
- [Memory](#)

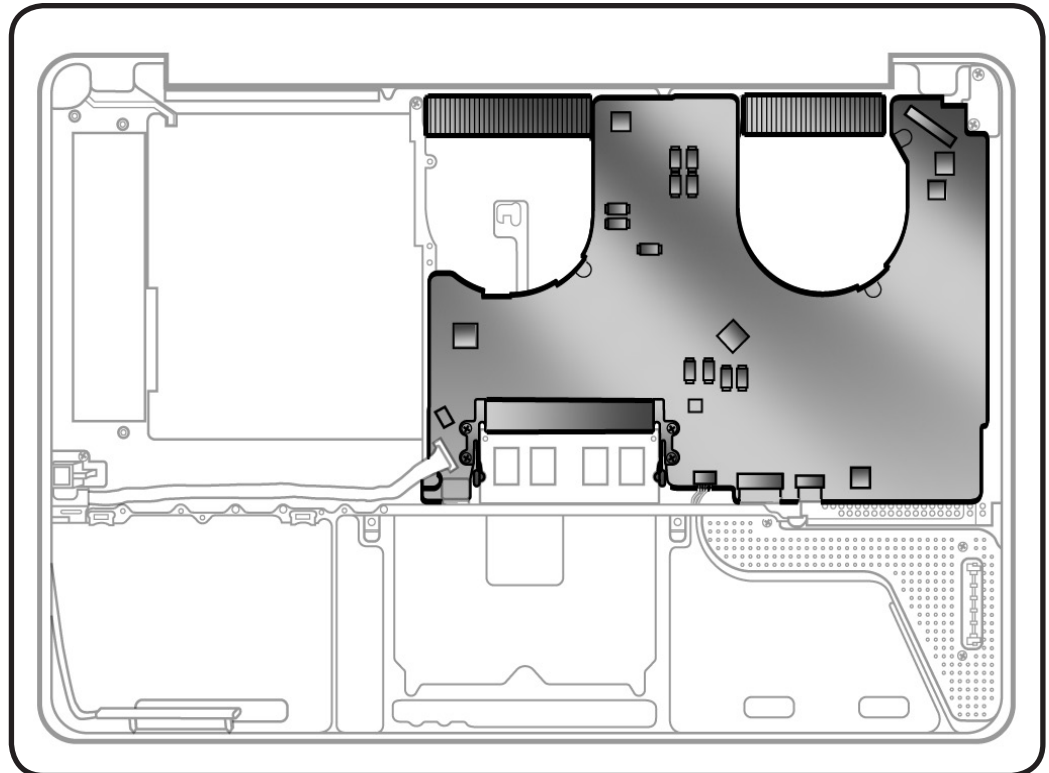

Tools

- Clean, soft, lint-free cloth
- ESD wrist strap and mat
- Magnetized Phillips #00 screwdriver
- Black stick

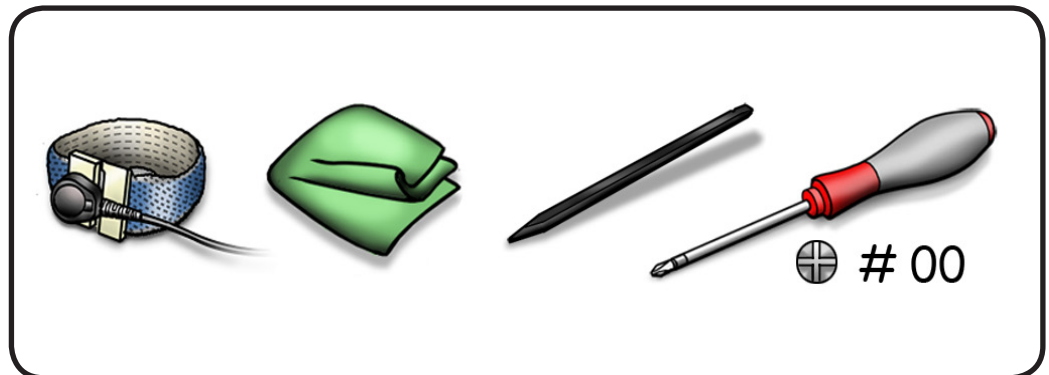



Removal

- 1 Locate camera/AirPort/Bluetooth/connector and black shim on the logic board.
- 2 Using a black stick, pry the shim from the logic board and set it aside. If you don't remove the shim prior to removing the cable, you could damage the logic board and/or the camera cable.

Important: Be sure to replace the shim after you reconnect the cable. Otherwise, the cable could work loose, resulting in no video.

Note: A shim is included with a replacement logic board.

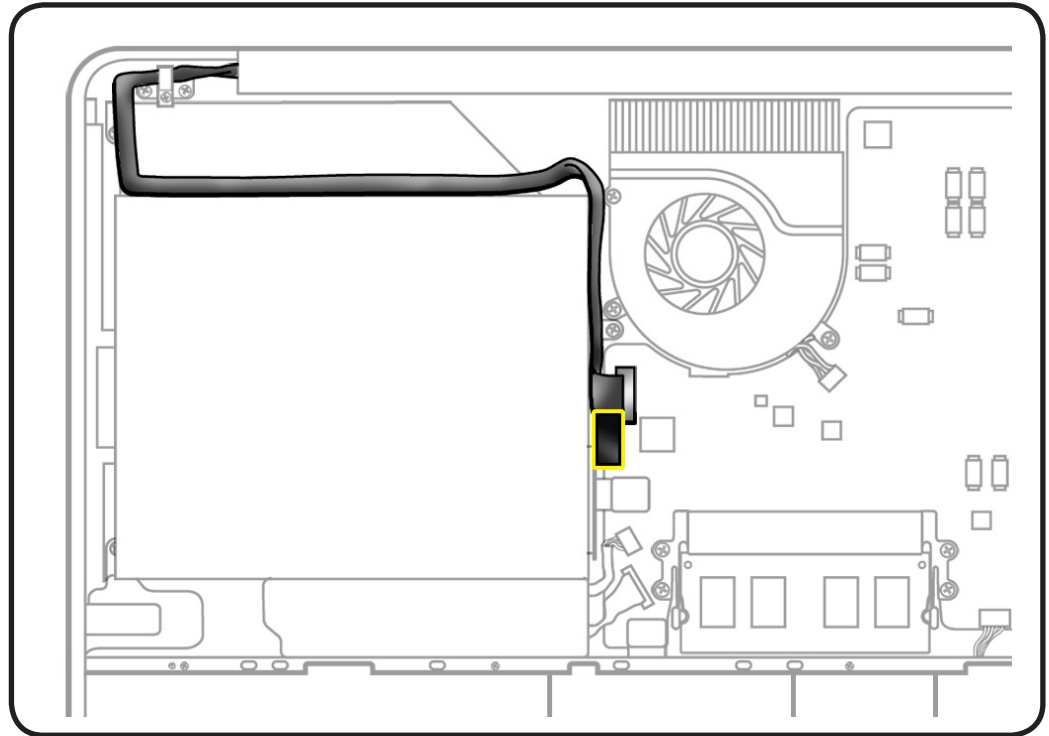

- 3 Peel EMI gasket off camera cable connector (A).
- 4 Disconnect camera cable from logic board (B). Pull cable toward the optical drive, on same horizontal plane as the logic board.

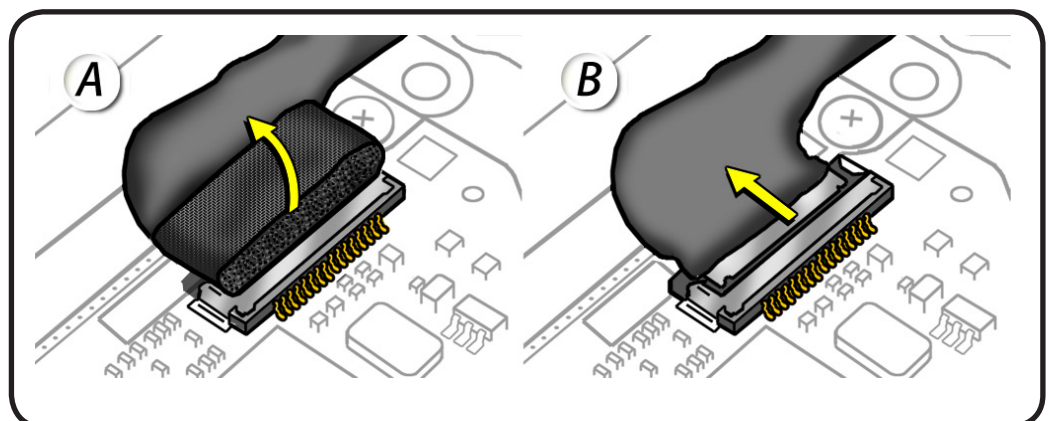



Caution: The LVDS cable/lock bar is very fragile, handle with care. A broken lock bar results in a display assembly replacement.



- 5 Peel EMI gasket off the top of LVDS cable, pull towards the fan.

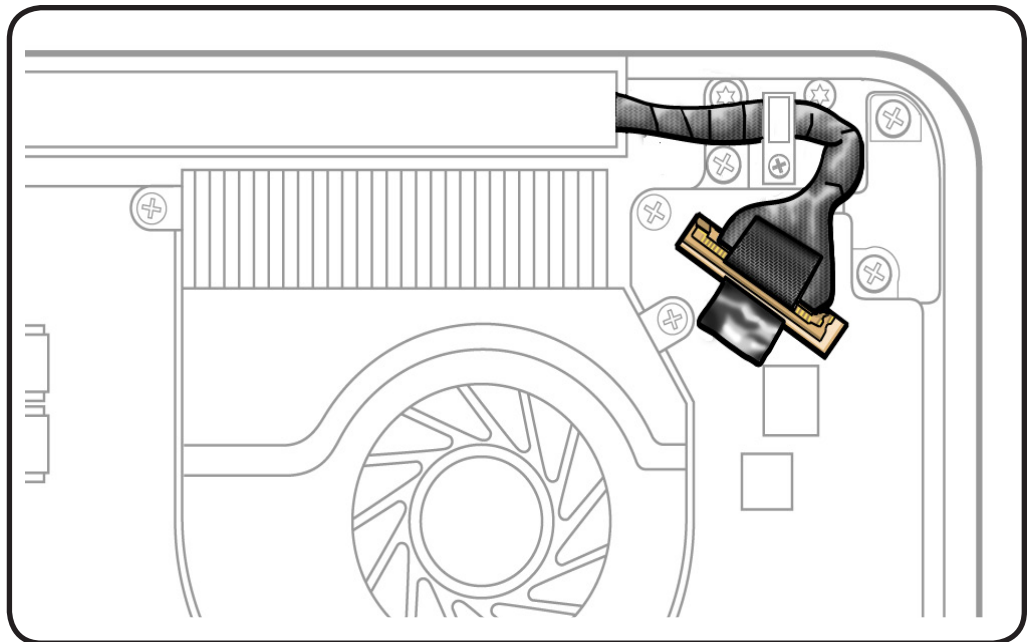

- 6 To disconnect LVDS cable grasp black tab and gently swing LVDS lock bar up and back to unlock the cable

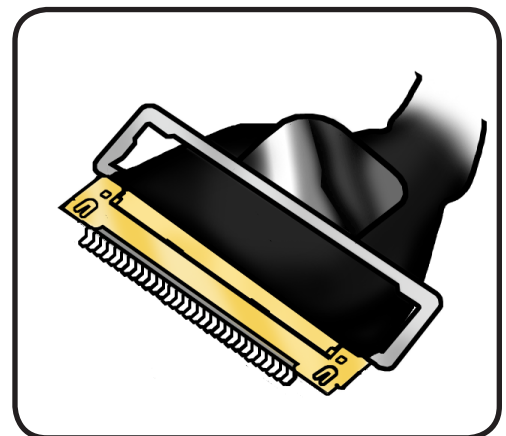
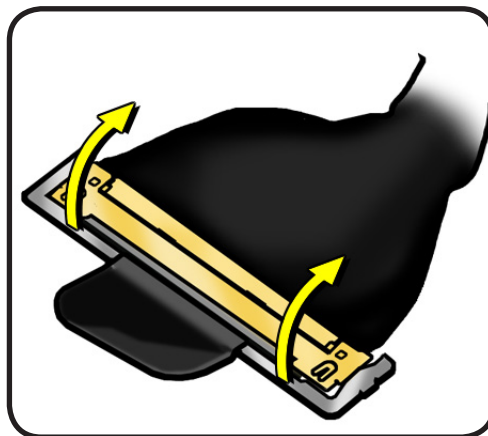

- 7 Slide cable out of connector by pulling the cable. Do not pull the black tab or lock bar.

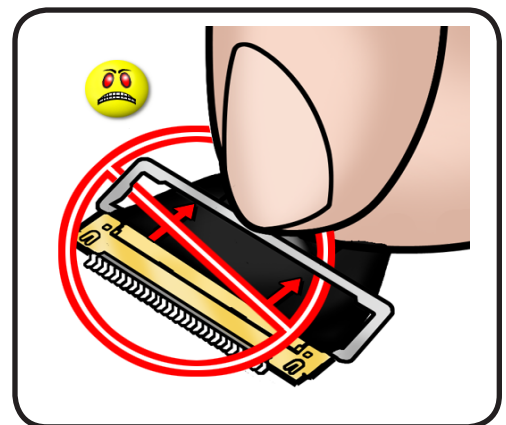
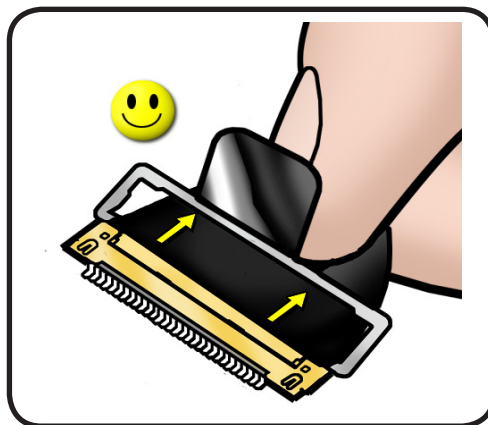



Replacement Caution: To prevent video “noise,” a whining sound, no video, or a short to the logic board, be sure to place foam gasket on LVDS connector—**positioned precisely where shown**—**after** cable is fully connected to logic board.

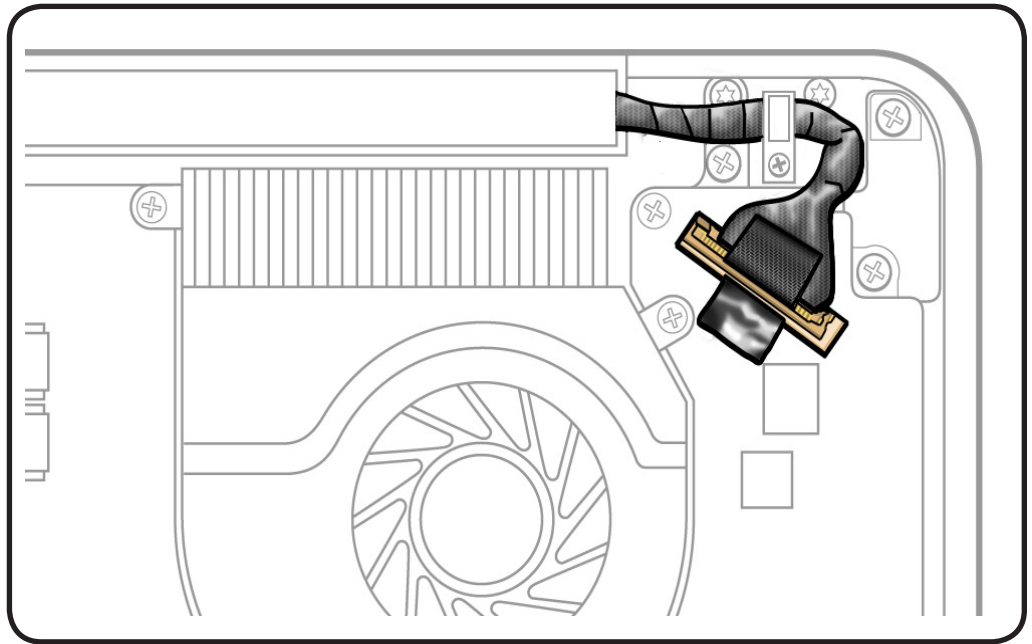

8 Caution: Carefully disconnect 9 more cables in the order shown:

- (1) keyboard flex cable
- (2) optical drive
- (3) right speaker
- (4) hard drive
- (5) trackpad flex
- (6) IR/Sleep (see Caution in step 9 and 10)
- (7) battery indicator light
- (8) battery power
- (9) express card cage

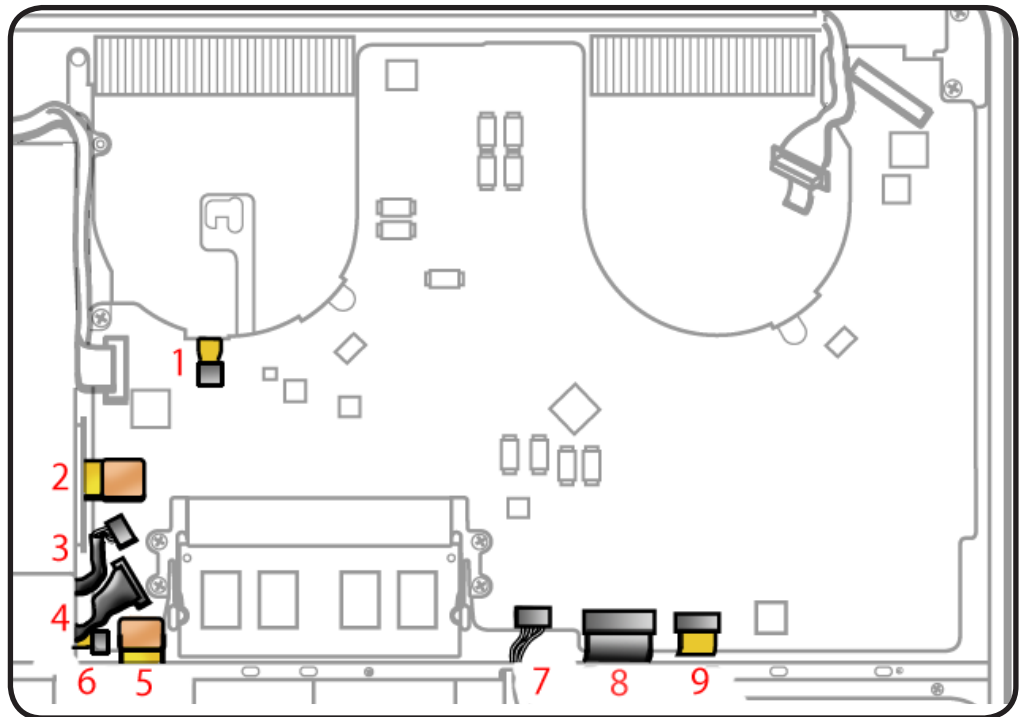



- 9 CAUTION:** With a fingernail or black stick, carefully flip the IR/Sleep indicator locking lever connector to the “open” position. Careful not to break the locking lever.

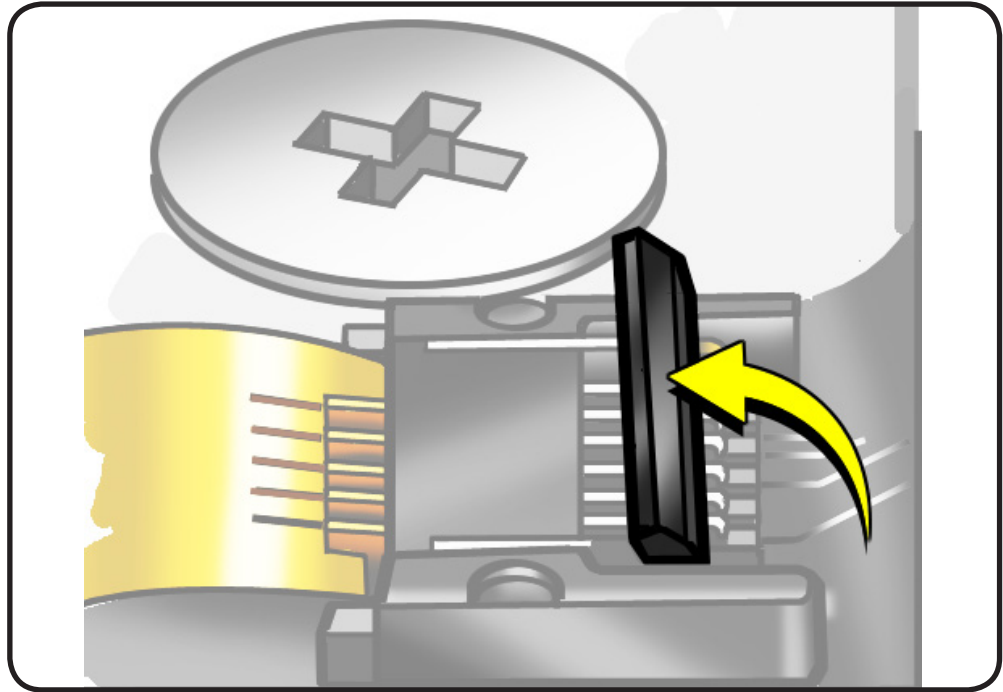

- 10** Without straining the cable, pull it straight out of the connector.

Replacement Note:
Flip all locking levers on the logic board to the closed position (down) to return board back to Apple.

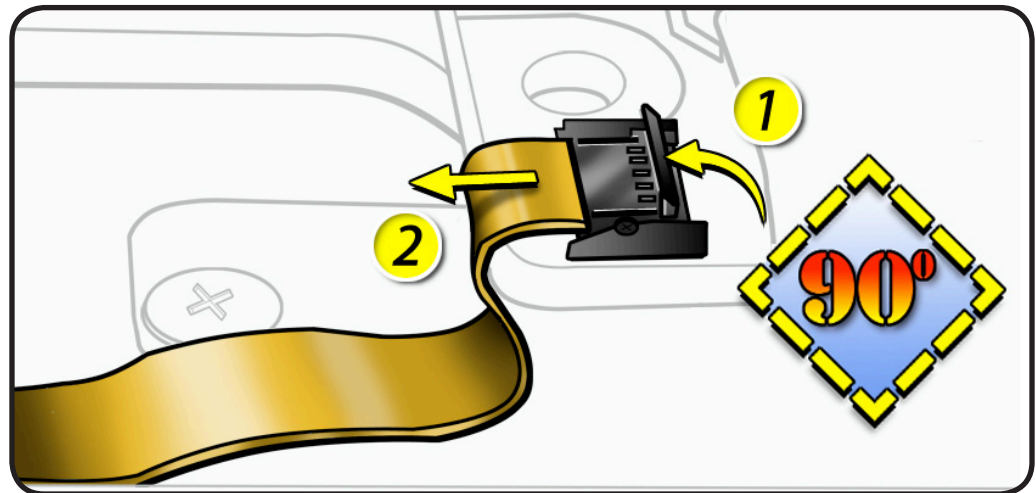



- 11** Remove 9 screws:
- 7 logic board (3.2-mm) 922-9754
 - 2 shoulder 3.5-mm (922-8753) screws on I/O bracket. (**Note:** I/O bracket and screws are present only on early production top cases. For additional information, refer to Take Apart: Top Case Information.)

Note: Do not remove or loosen the 2 (7-mm) MagSafe screws in top right corner while servicing the logic board.

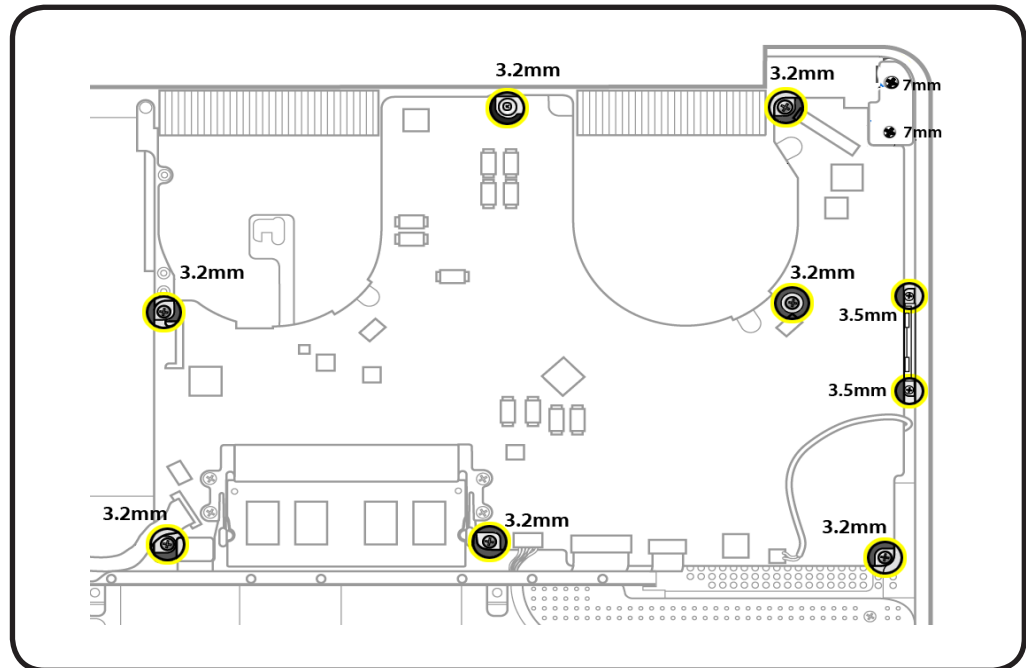

- 12** Carefully lift board from the ports and, on the underside of the board, disconnect the MagSafe cable.

- 13** Tilt board vertically and disconnect the battery power cable.

- 14** Lift off logic board.

- 15** Do not remove the speaker, microphone or heatsink if reinstalling the same logic board.

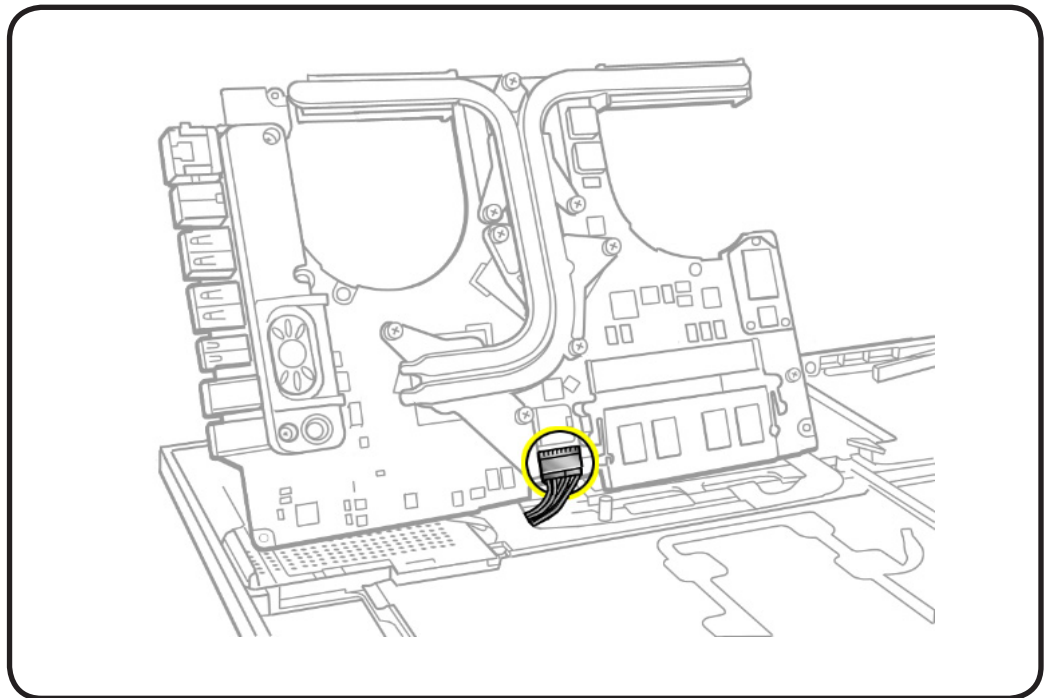



16 Replacement Note: If

replacing logic board,
transfer:

- camera cable shim
(or replace with new
shim included with
logic board)
- left speaker
- microphone
- heatsink
- memory



Heatsink

First Steps

Remove:

- [Access door](#)
- [Battery](#)
- [Bottom case](#)
- [Fans](#)
- [LVDS cable guide](#)
- [Memory](#)
- [Logic board](#)

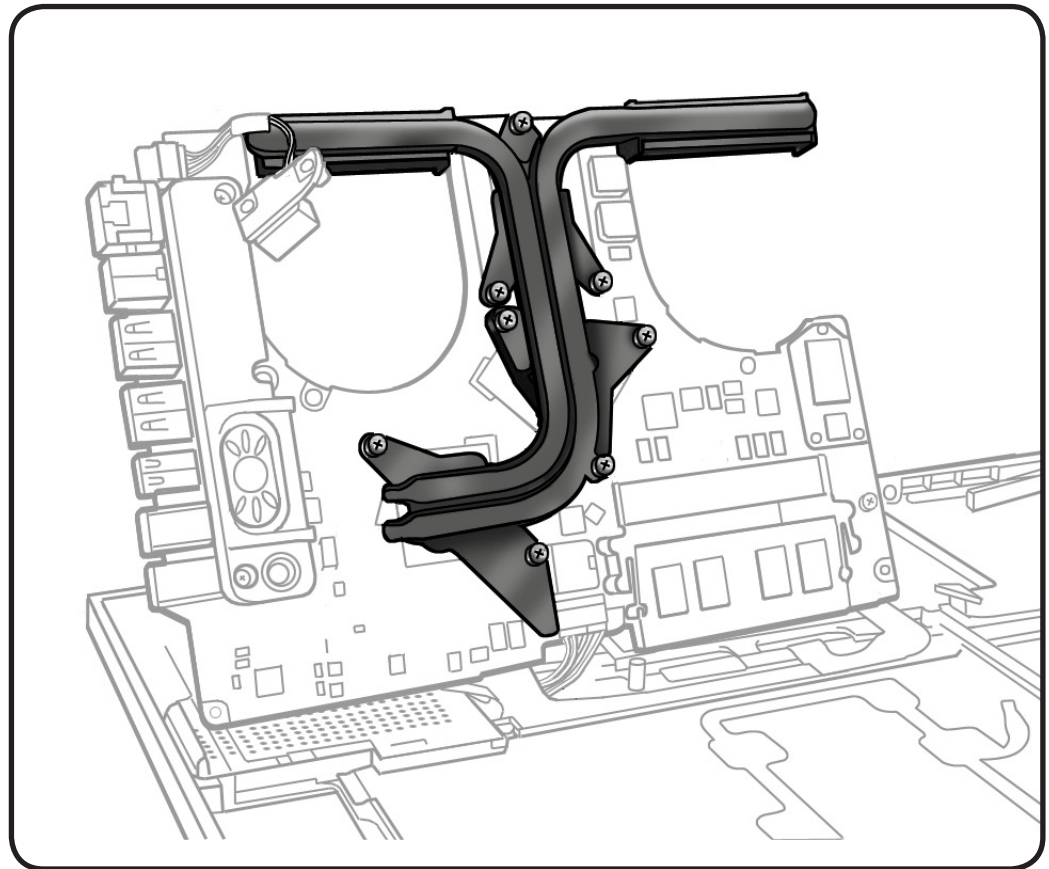

Tools

- Clean, soft, lint-free cloth
- ESD wrist strap and mat
- Magnetized Phillips #0 or #1 screwdriver
- Thermal grease syringe
- Alcohol pads
- Black stick

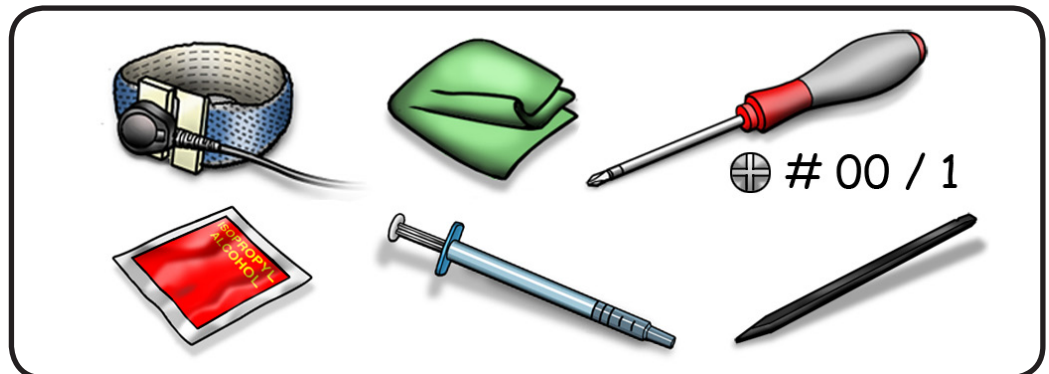



Removal



Caution: Hold heatsink by edges, not by the heat pipes:

- 1 Disconnect the thermal sensor cable using a black stick.
- 2 Remove 8 (8.39-mm) 922-8799 screws.
- 3 Keeping heatsink parallel to logic board, gently wiggle the heatsink to loosen the bond to the board.
- 4 With a black stick, scrape off thermal grease and use alcohol pad to clean thermal pads and microprocessors.

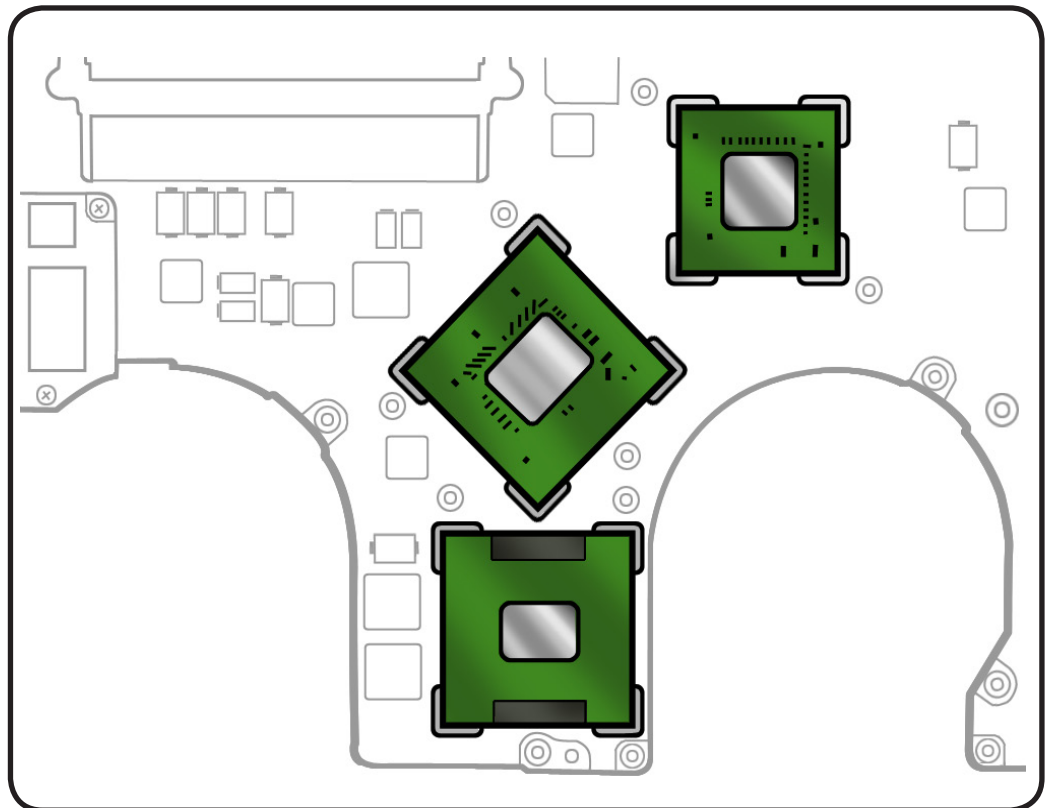
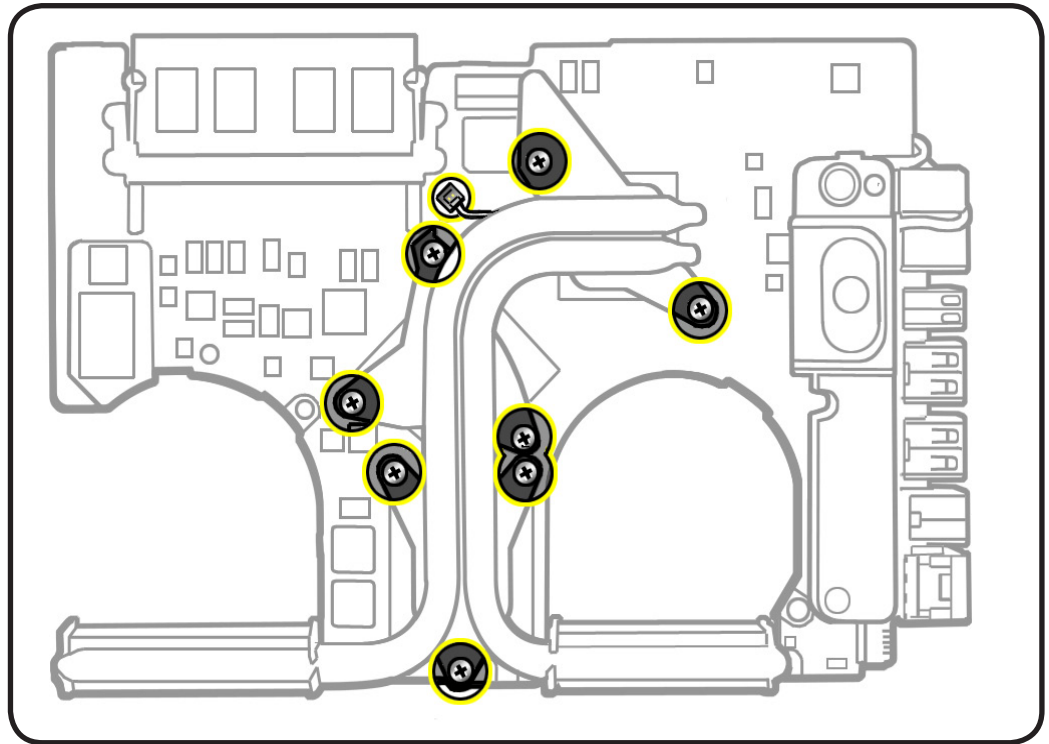



Replacement

Important: New heatsinks include pre-applied thermal grease. Follow steps 1-2 only if re-installing the original heatsink.

- 1 Caution:** The syringe contains enough thermal grease for 3 microprocessors.

Use a pen to mark the syringe in thirds.



- 2** Inject 1/3 of grease on the center of each microprocessor.
- 3 Important:** Connect the thermal sensor. The computer will not function with the sensor disconnected.
- 4** Lower the heatsink over the logic board.

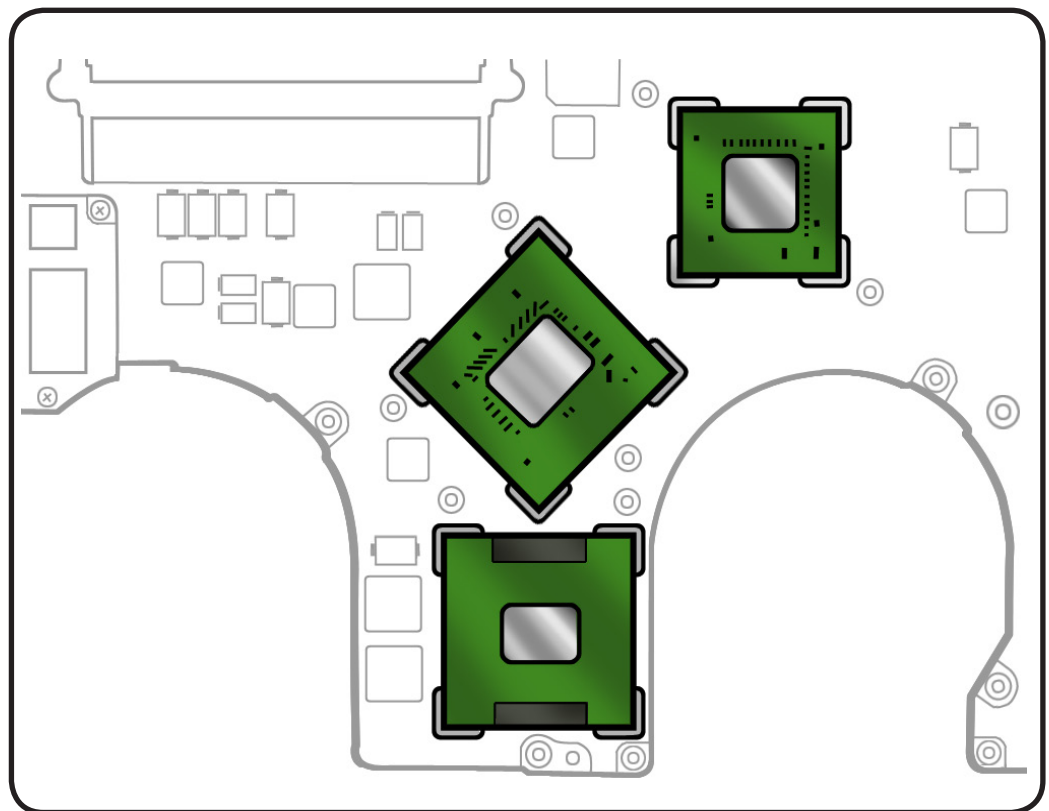
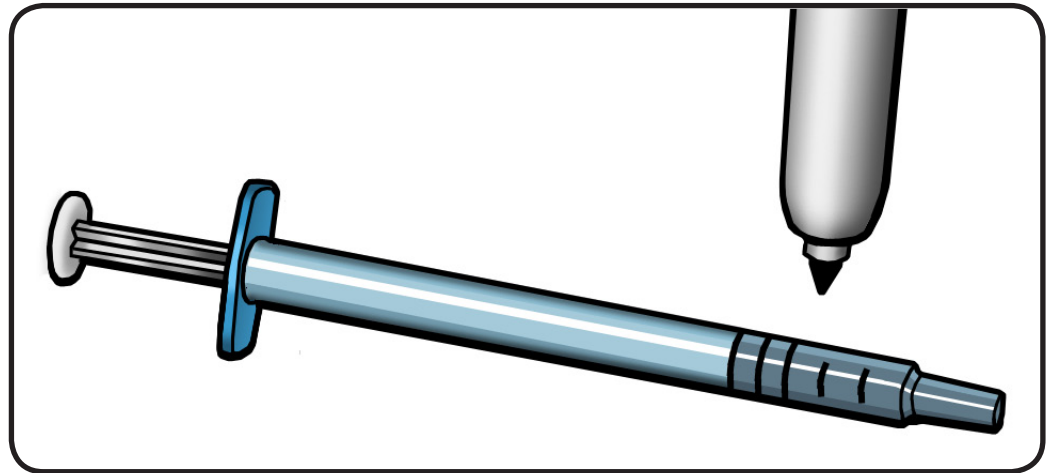



- 5** Install heatsink screws in order, 1/2 way first, then tighten the rest of the way.

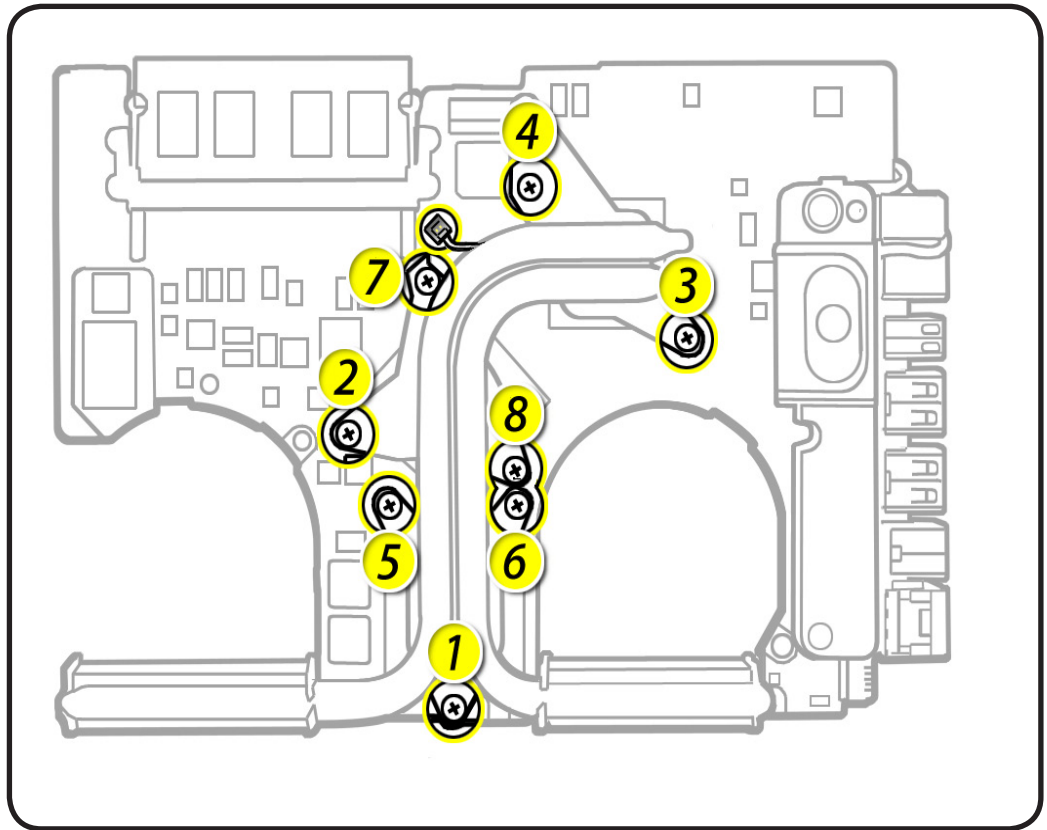



Trackpad

First Steps

Remove:

- [Access door](#)
- [Battery](#)
- [Bottom case](#)
- [Fans](#)
- [Logic board](#)
- [Optical drive](#)
- [Right speaker / subwoofer](#)

Trackpad Kit 922-9008

includes:

- trackpad
- black label
- 2 metal flexures
- 6 Ph#00 screws
- 1 tri-lobe #0 set screw

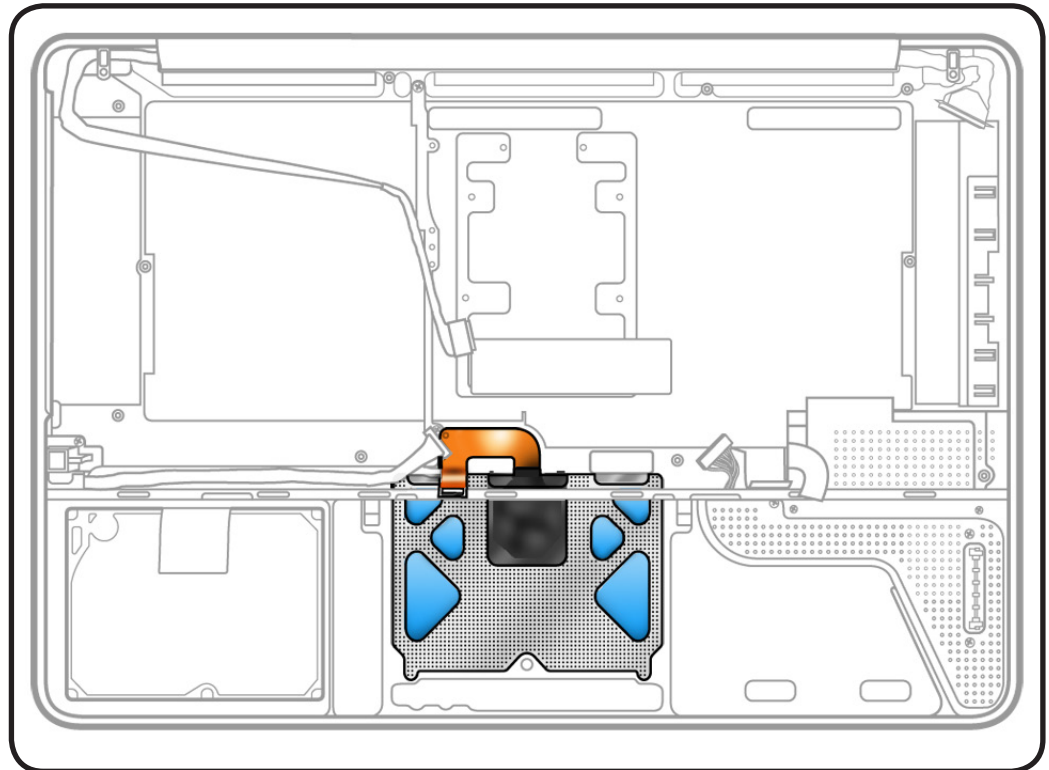

Tools

- ESD wrist strap and mat
- Sticky (Post-It) notes
- Black stick
- Magnetized tri-lobe #0 screwdriver (922-8991)
- Magnetized Phillips #00 screwdriver

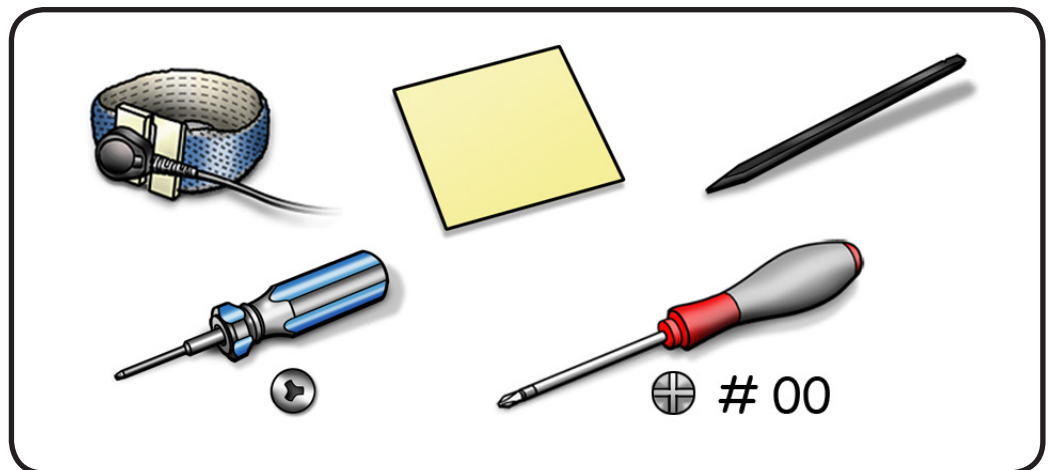



Removal

- 1 Remove trackpad flex cable from adhesive on mounting ramp.

Note: If a bar code label stays stuck to adhesive, be sure to remove it.

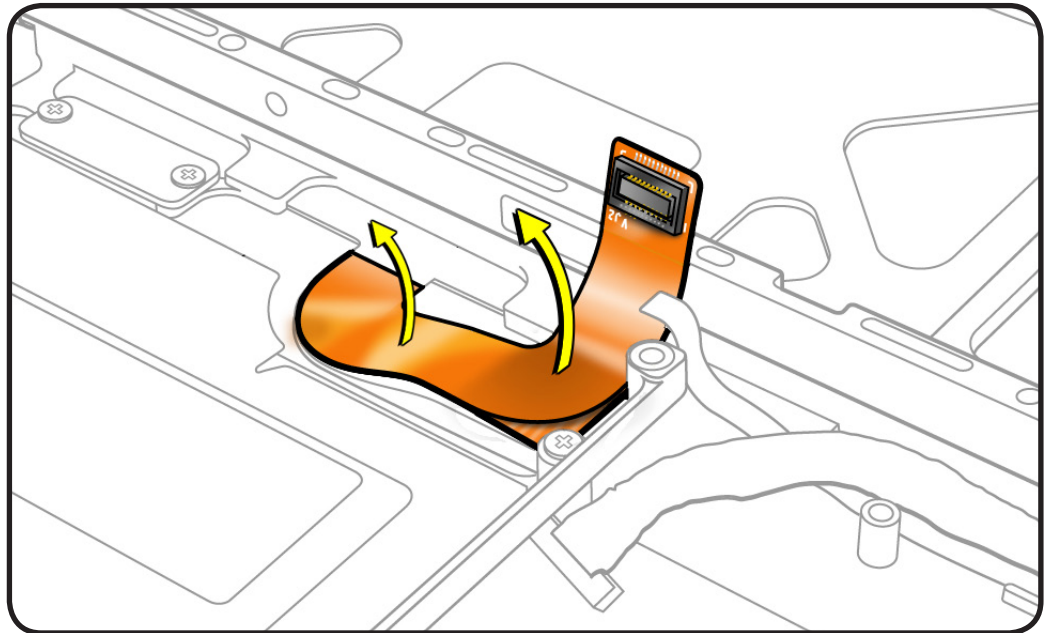

- 2 Remove 6 short Phillips #00 screws from flexures.

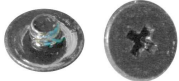

- 3 Remove 1 tri-lobe #0 set screw.



- 4 Dispose of old screws; they lose their ability to hold securely if reused.

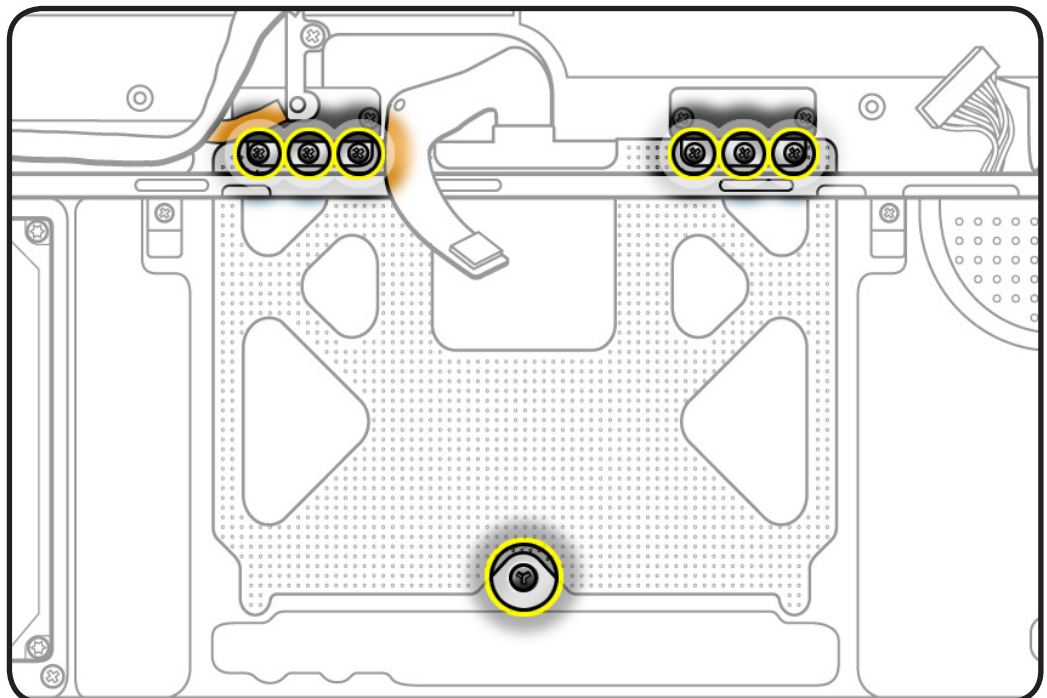



- 5** Hold trackpad and flex cable and press down on edge closest to logic board.

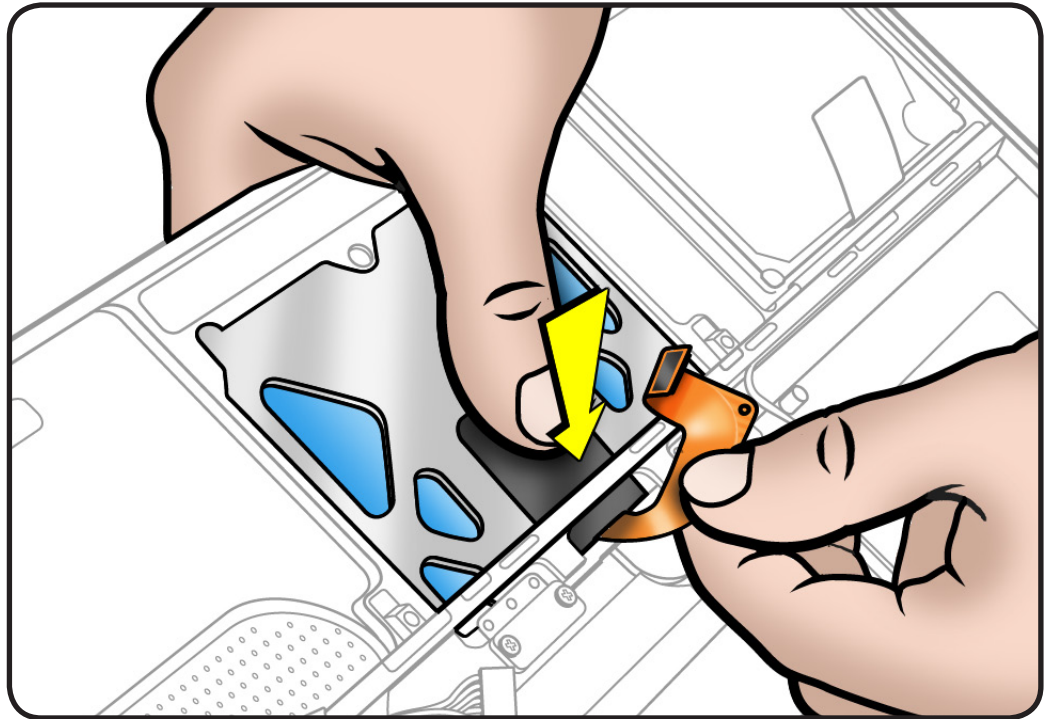

- 6** Slide trackpad down and back towards keyboard to clear supports in front edge of top case.

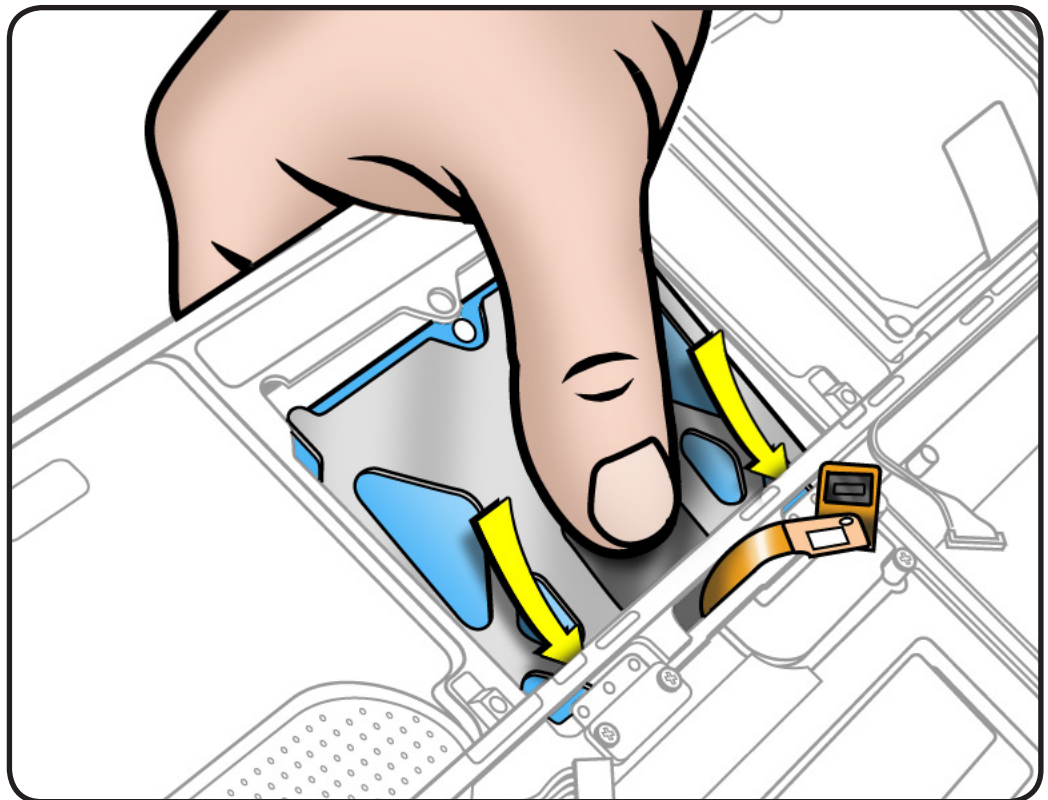



- 7** Spiral trackpad down and away from top case, taking care to route flex cable through hole.

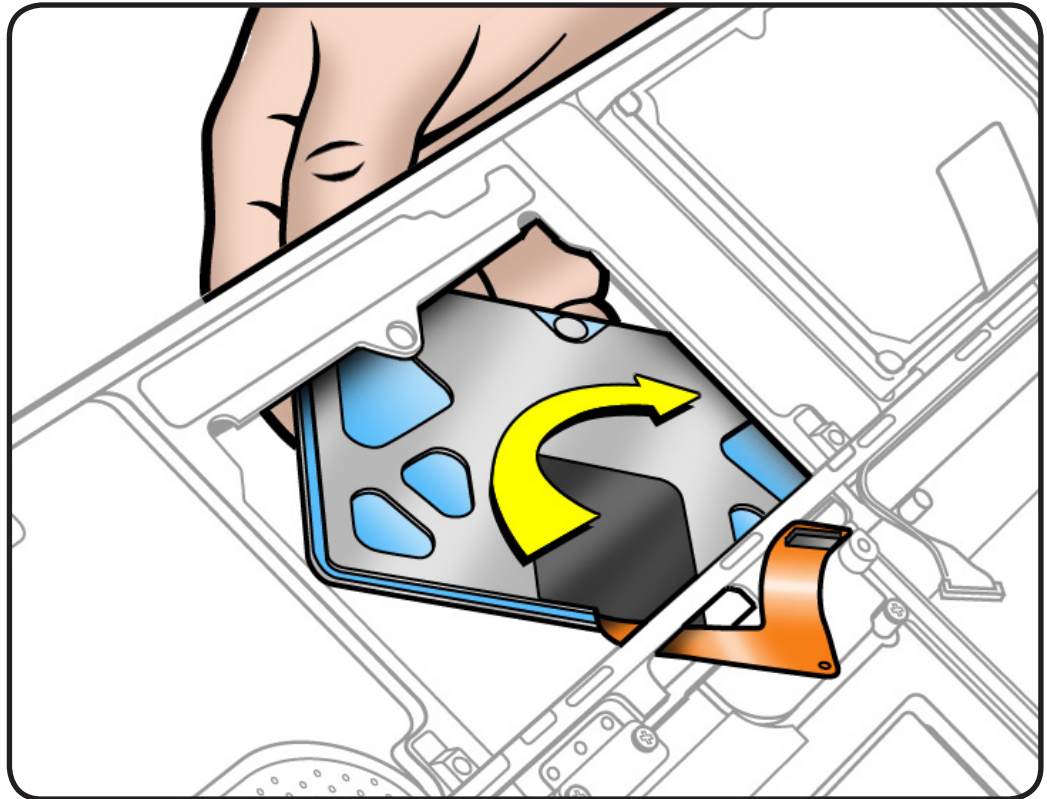

- 8** Remove 4 Phillips #00 screws from black plastic stiffeners.



Keep screws and stiffeners for reuse.

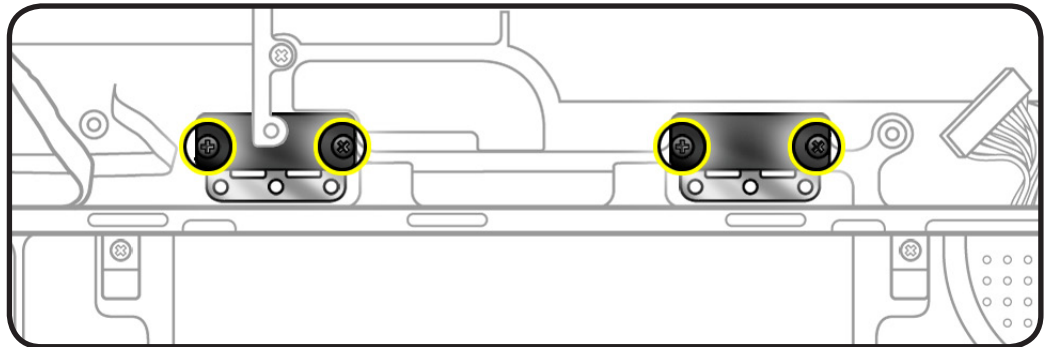

- 9** Remove 2 flexures (thin metal pieces).

- 10** Dispose of old flexures; they are matched to each individual trackpad by thickness.

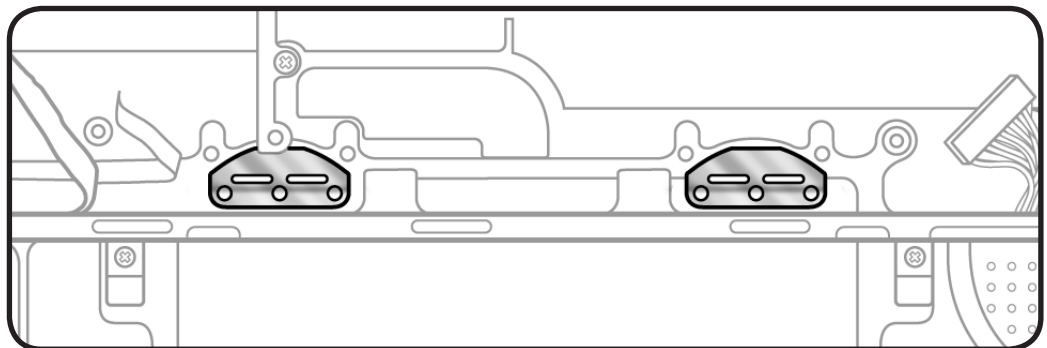



Replacement

Important: Dispose of old flexures, 6 short Phillips screws, and 1 tri-lobe set screw, and only use new ones included with trackpad kit.

- 1 Peel and adhere black label (included with new trackpad) to cover trackpad stiffener as shown.

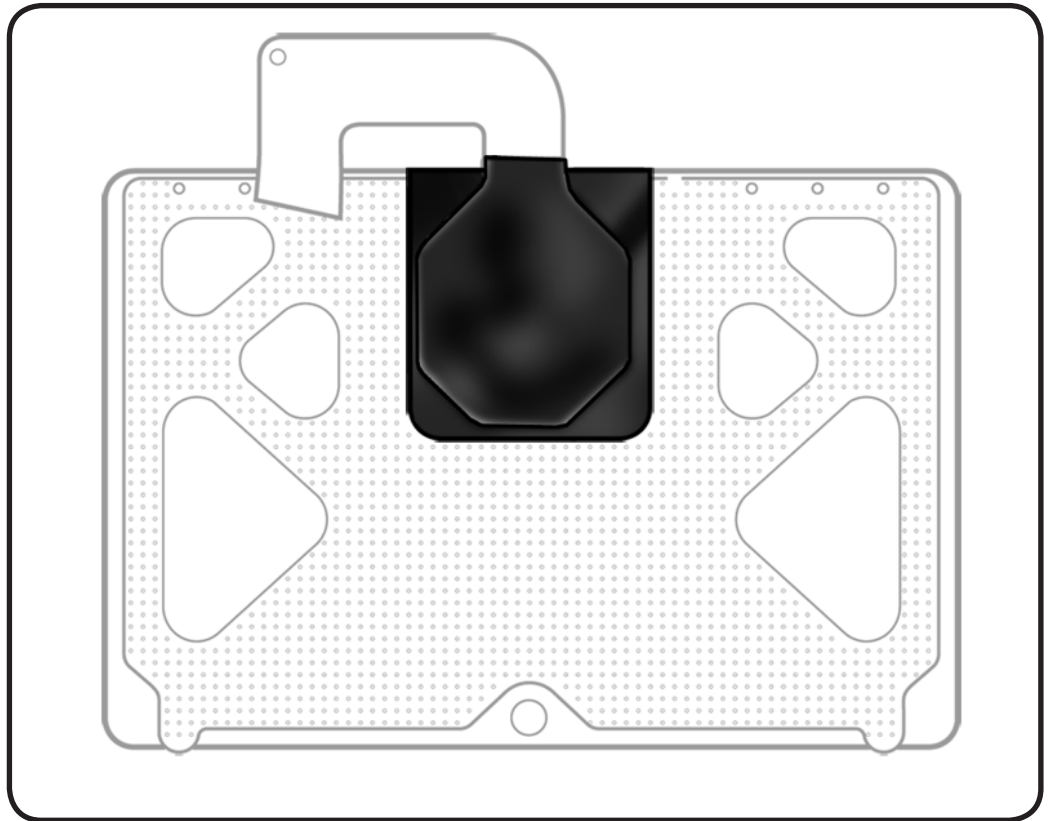

- 2 Align new flexures on positioning posts.

Note: This procedure will take patience and a steady hand. Try supporting the delicate flexures with a black stick underneath.

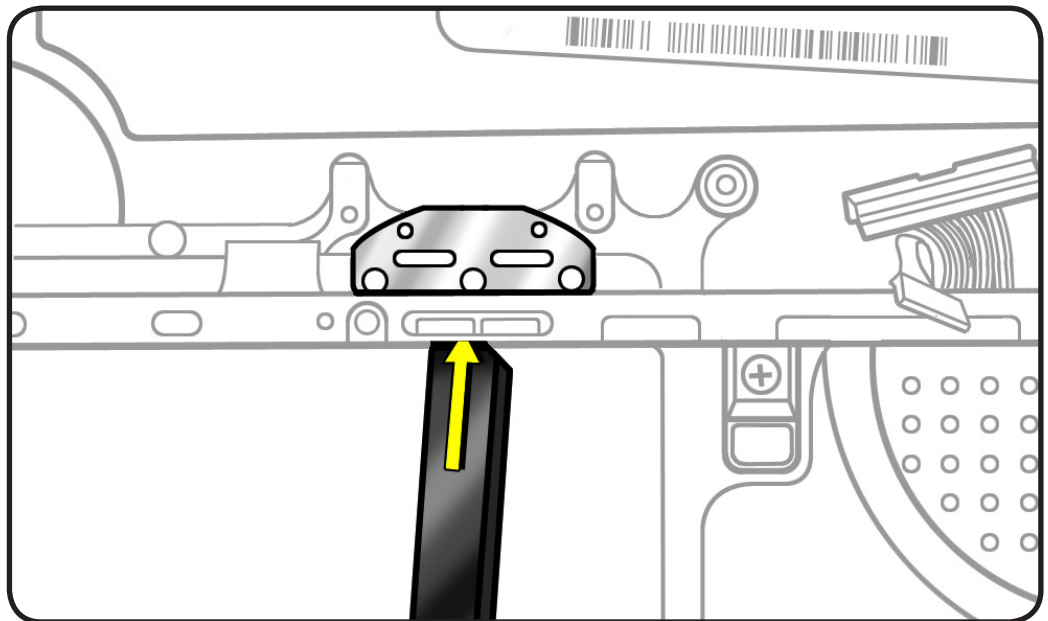



- 3 Align black plastic stiffeners so the raised semi-circle portion covers the flexure.



- 4 Tighten 4 Phillips #00 screws on stiffeners.

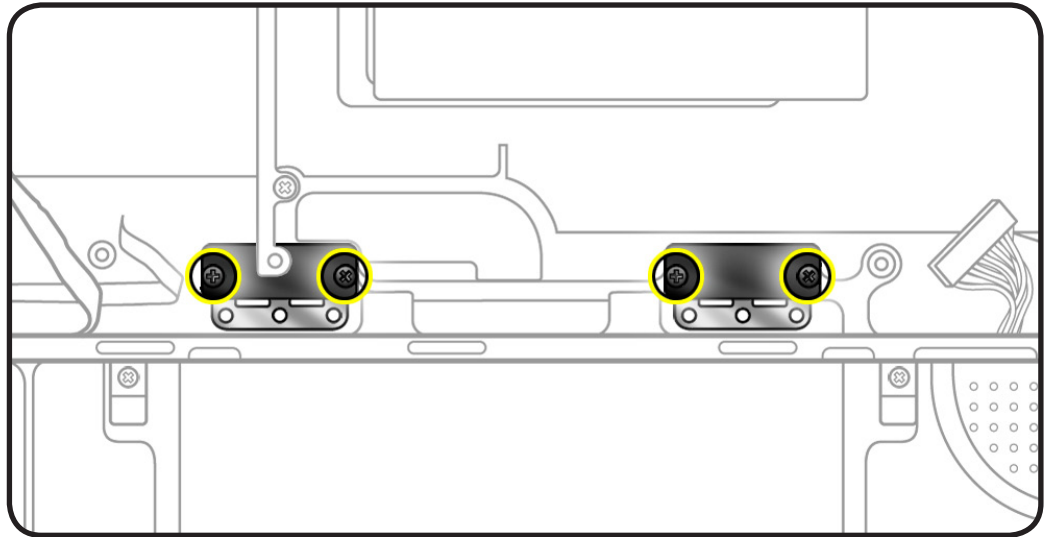

- 5 Carefully route flex cable through guidehole.

- 6 Spiral and pivot trackpad into place, inserting front edge first.

Important: Minimize rubbing edges of trackpad against top case while installing. This could cause invisible cracks to form in the glass of the trackpad.

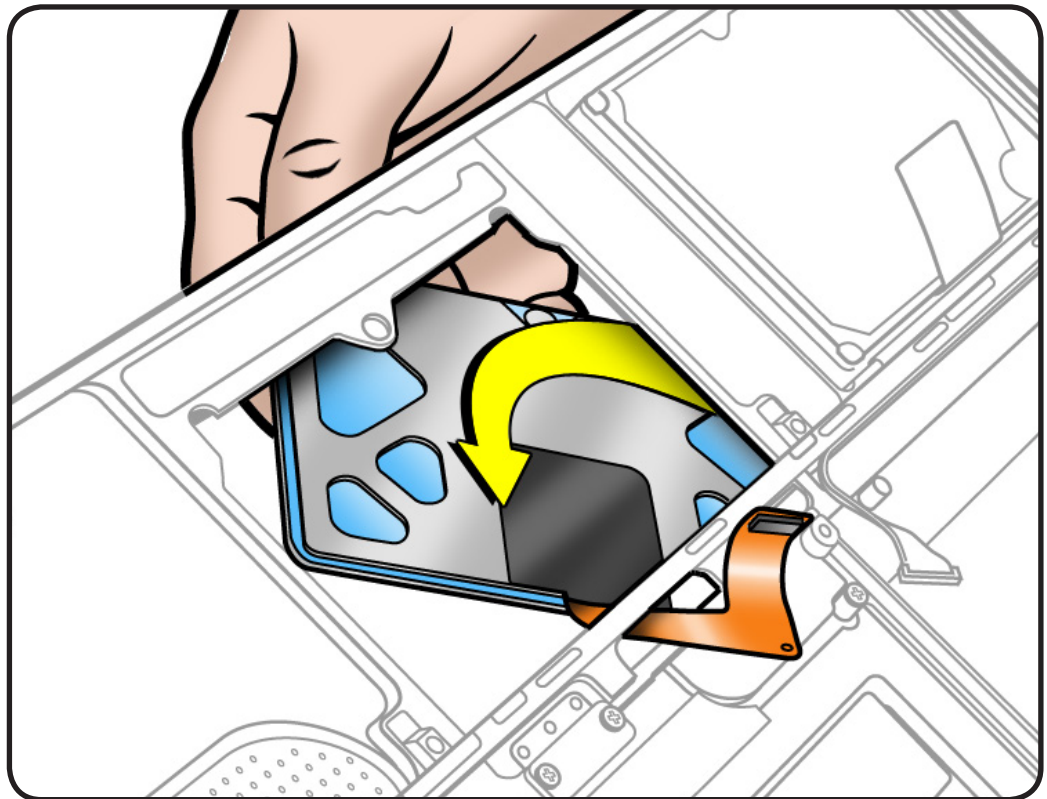



- 7** Loosely insert 6 short Phillips #00 screws into flexures. Do not tighten yet.

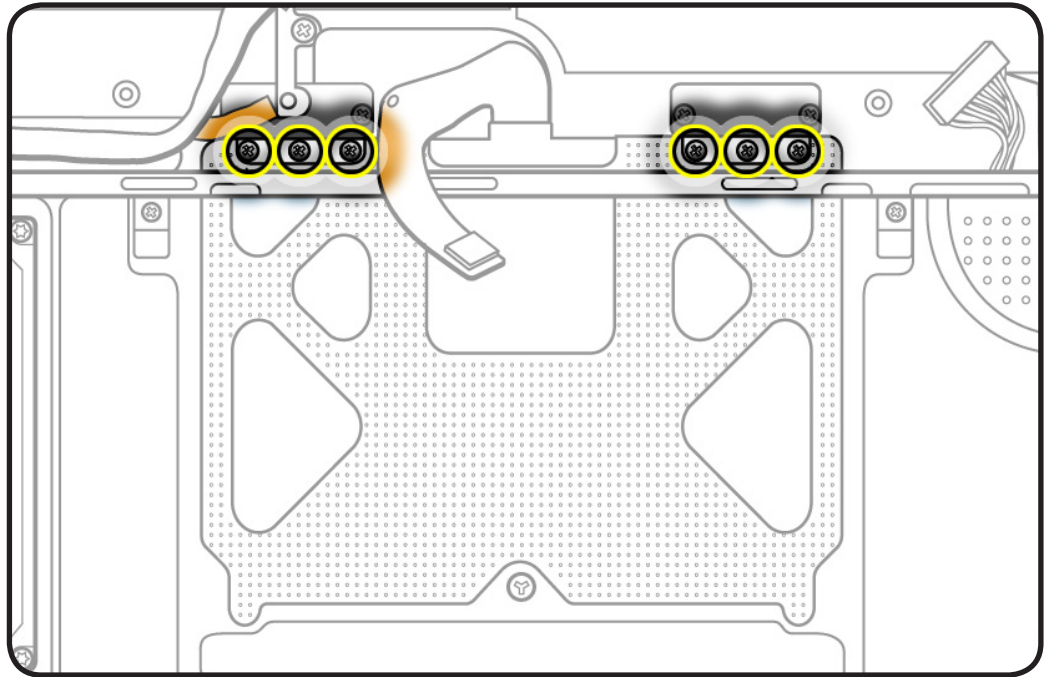
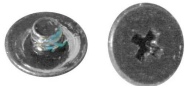

- 8** On the palm rest, insert one sticky (Post-It) note into gap on each of the four sides of trackpad.

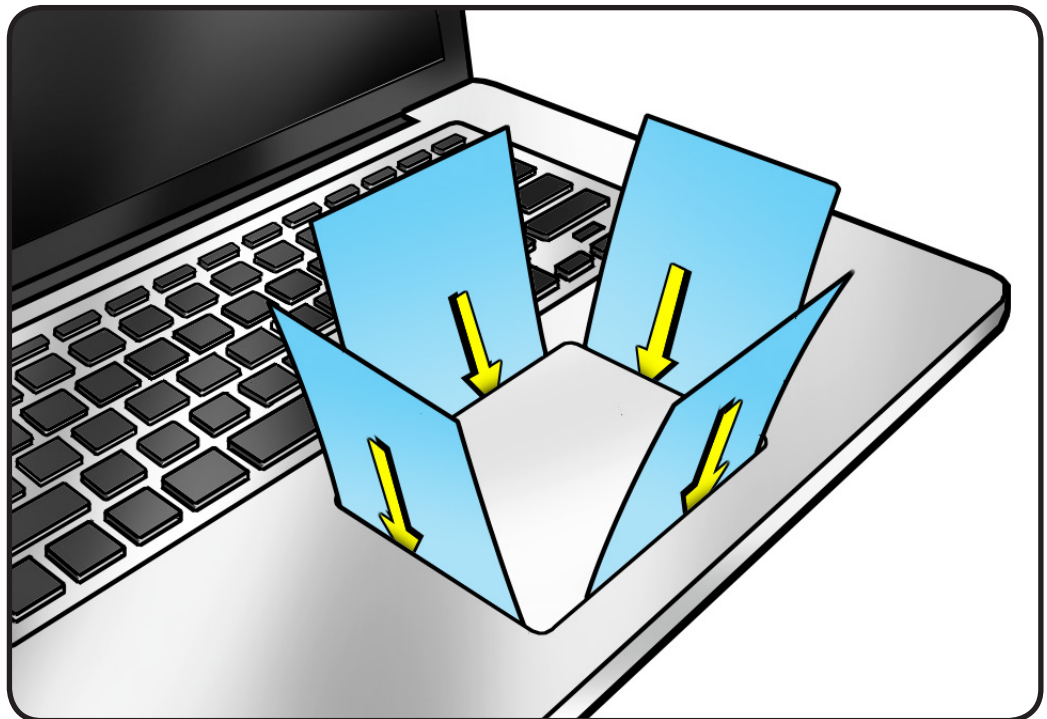



- 9** Fold sticky notes over so that top case can be laid flat.

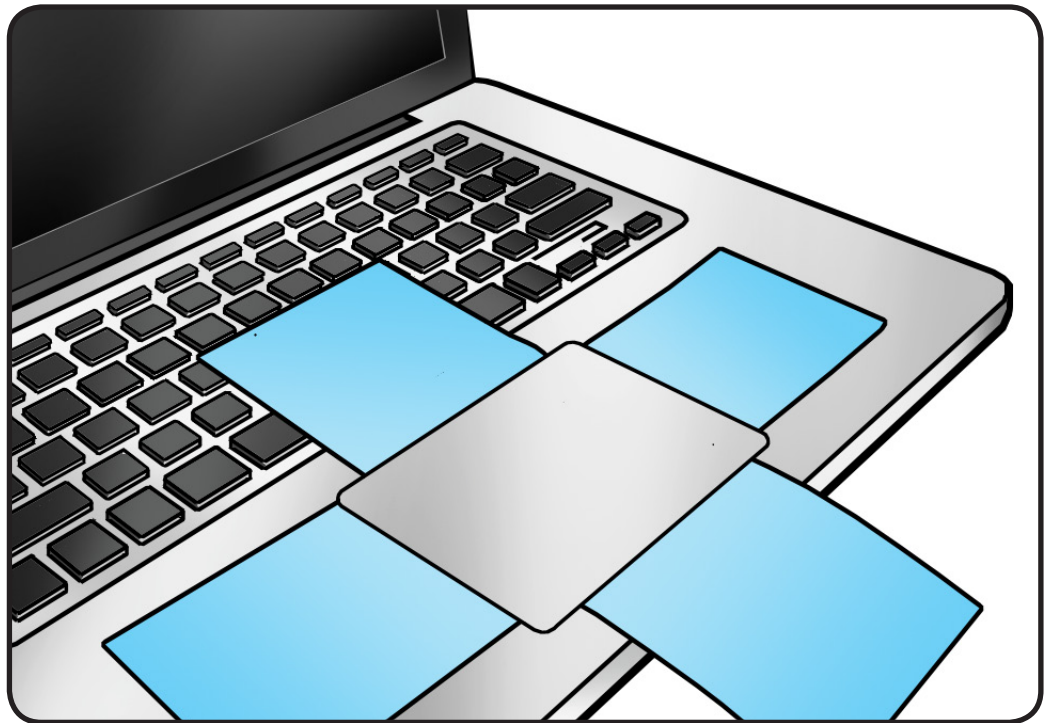

- 10** Tighten 6 short Phillips #00 screws at flexures.

- 11** Inspect that gaps between trackpad and top case are even on all sides. If not, loosen screws and adjust.

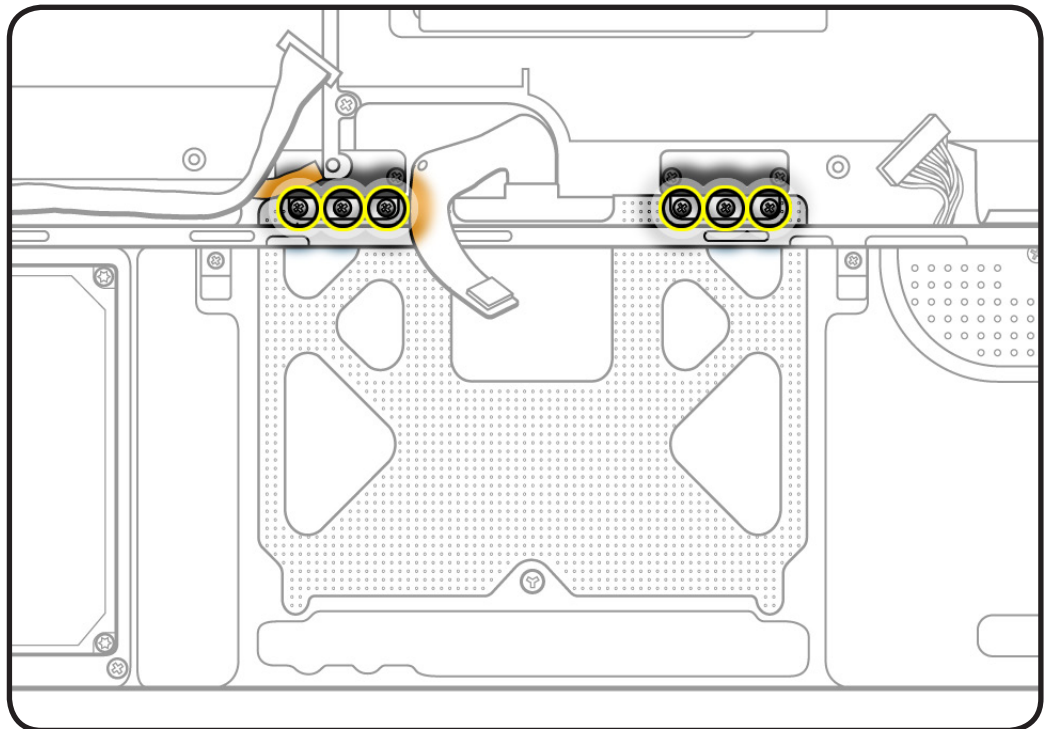



- 12** Insert tri-lobe #0 set screw.



- 13** Slowly turn set screw in small increments until trackpad has a normal clicking motion.

Important: Do not overtighten set screw or you may damage trackpad.

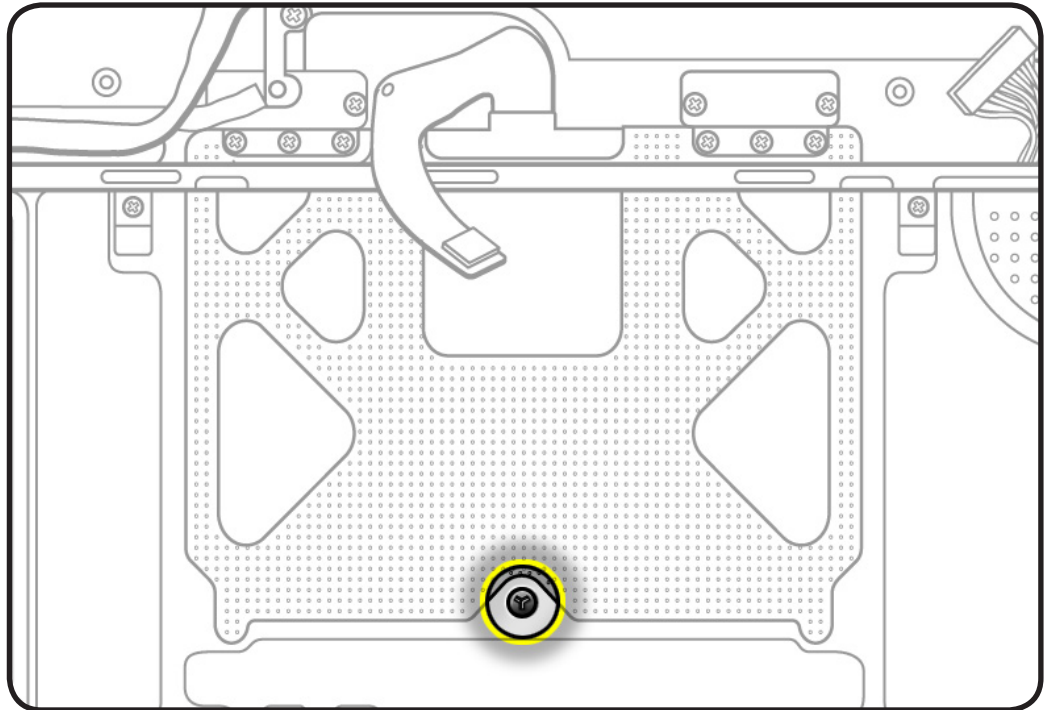

- 14** Adhere flex cable to mounting ramp.

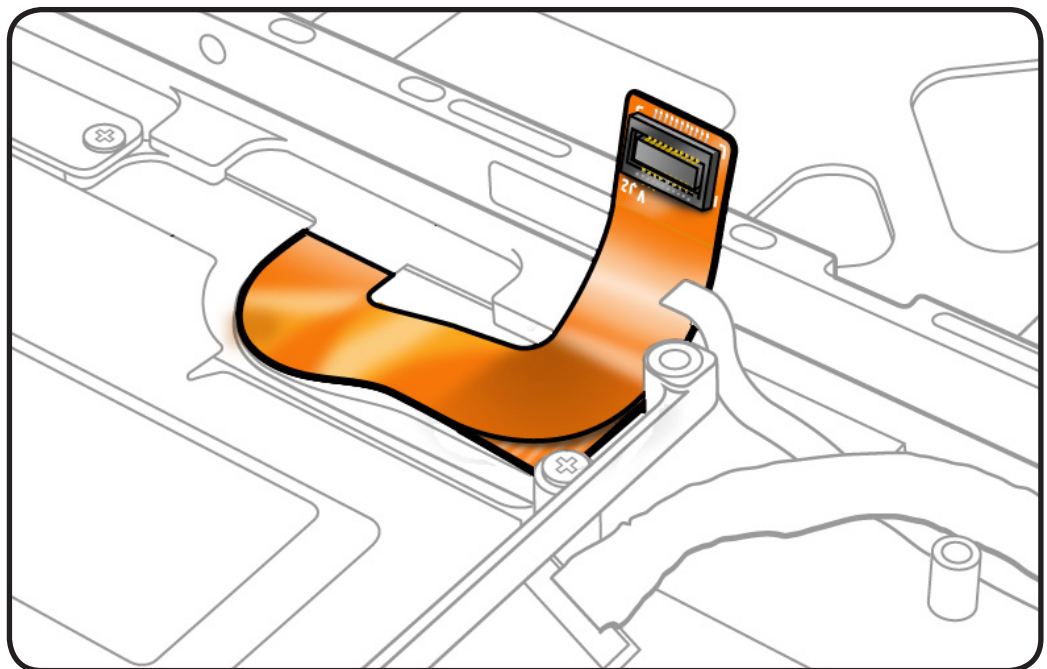



Battery Power Cable

First Steps

Remove:

- [Access door](#)
- [Battery](#)
- [Bottom case](#)
- [Battery connector cover](#)
- [Logic board](#)

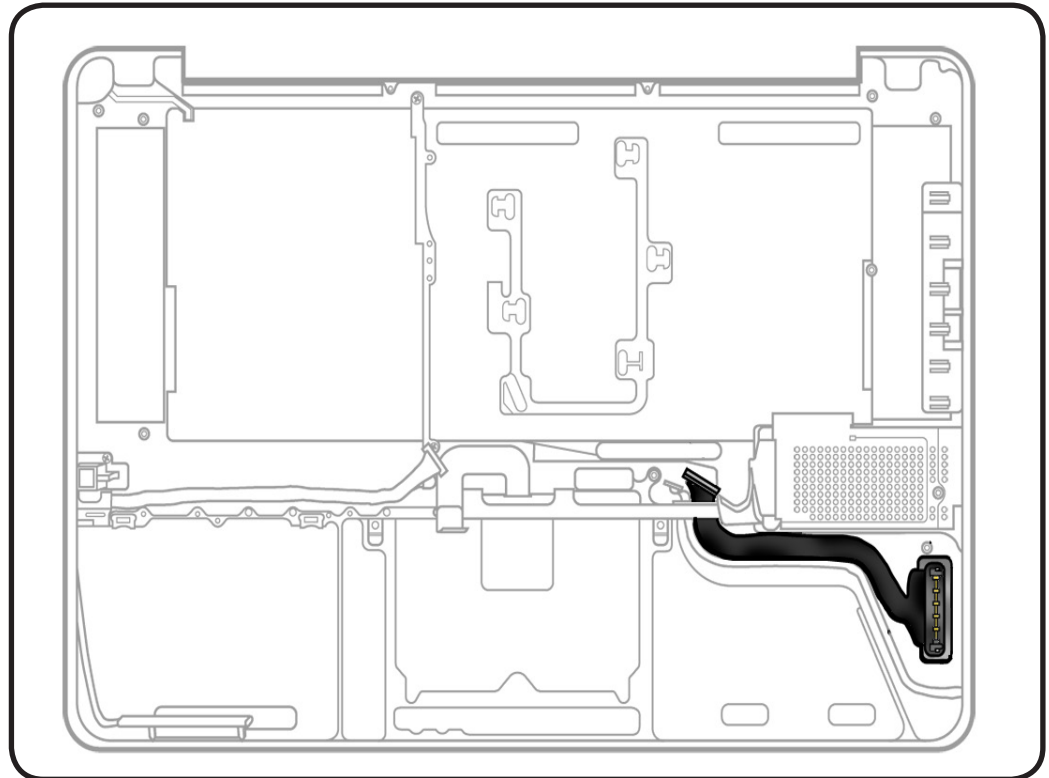

Tools

- Clean, soft, lint-free cloth
- ESD wrist strap and mat

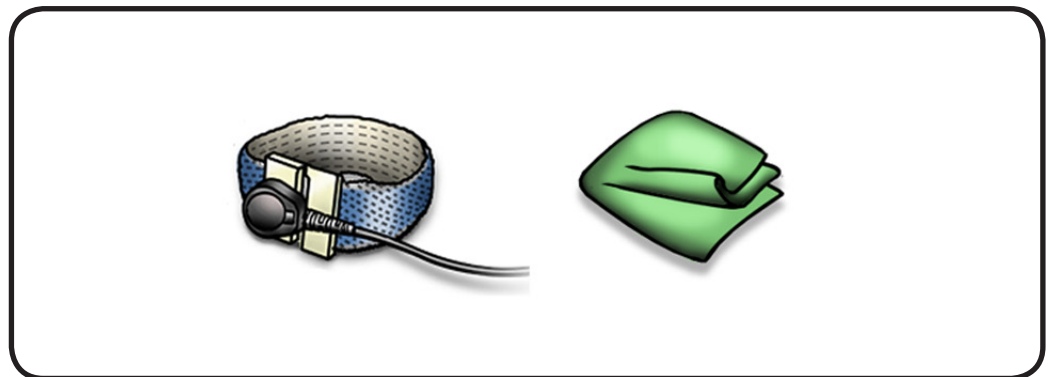



Removal

- 1 Disconnect the battery power cable, from the underside of the logic board.

Note: The cable can be disconnected without removing the logic board; however, to reconnect the cable, the logic board must be removed to access the connector.

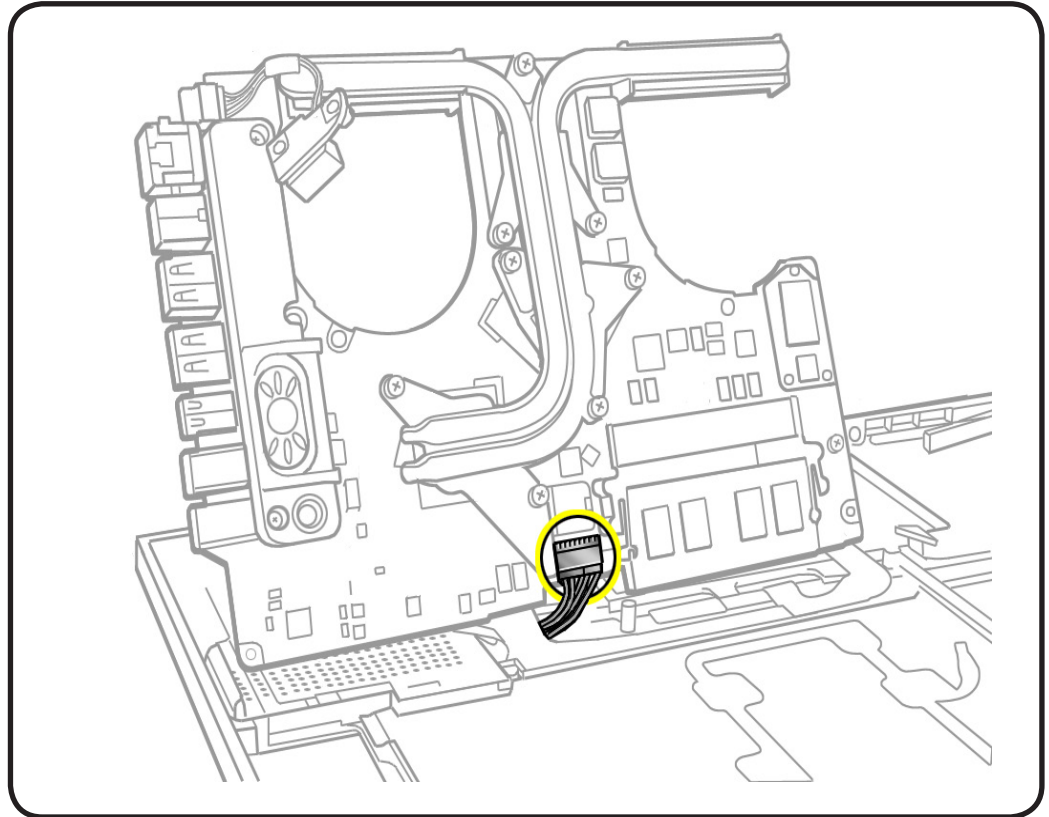

- 2 Pull the cable under midwall and peel it up from the top case.

Replacement Note: Press cable to top case so it lays flat.

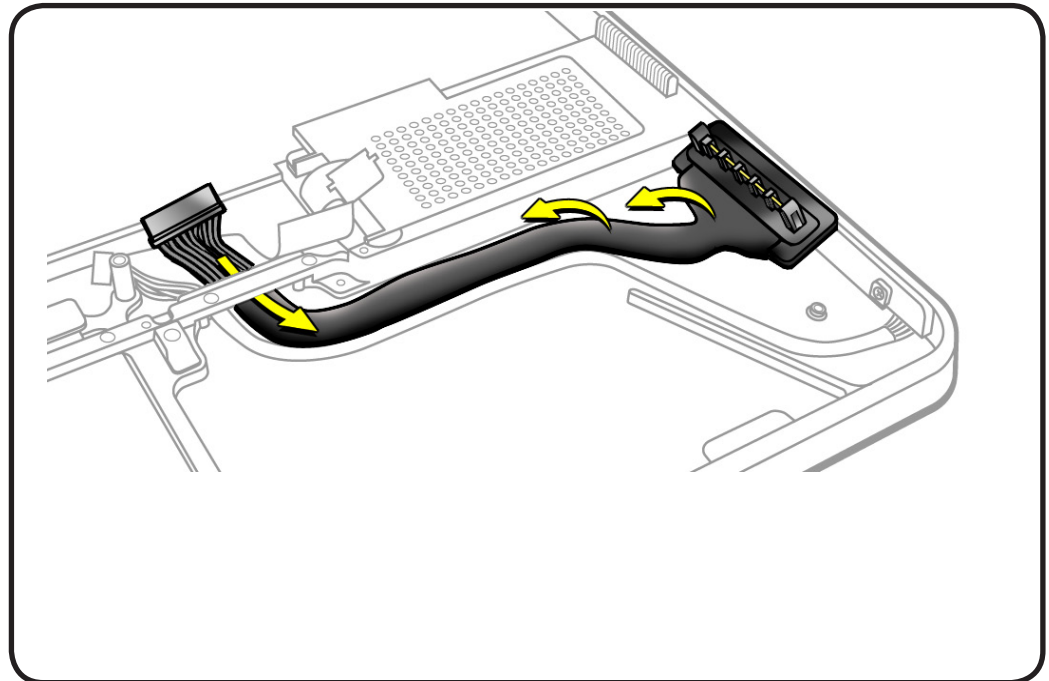



Left Speaker

First Steps

Remove:

- [Access door](#)
- [Battery](#)
- [Bottom case](#)
- [Fans](#)
- [LVDS cable guide](#)
- [Memory](#)
- [Logic board](#)

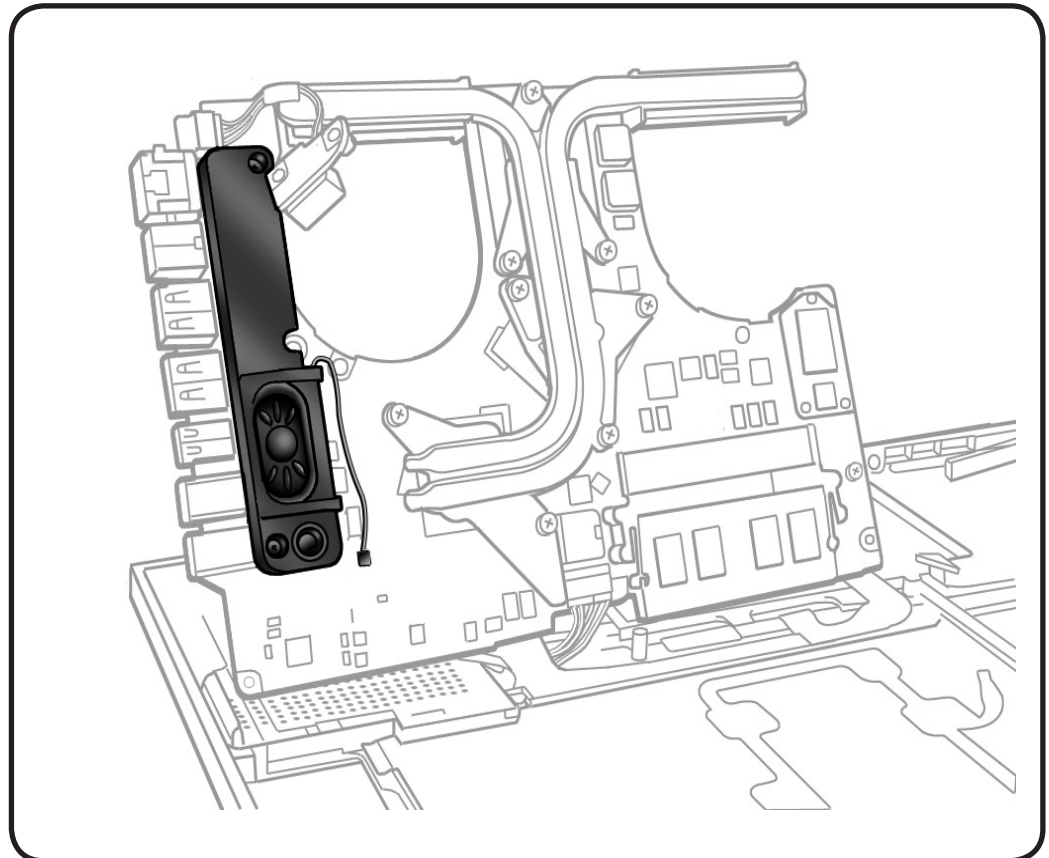

Tools

- Clean, soft, lint-free cloth
- ESD wrist strap and mat
- Magnetic Phillips #00 screwdriver

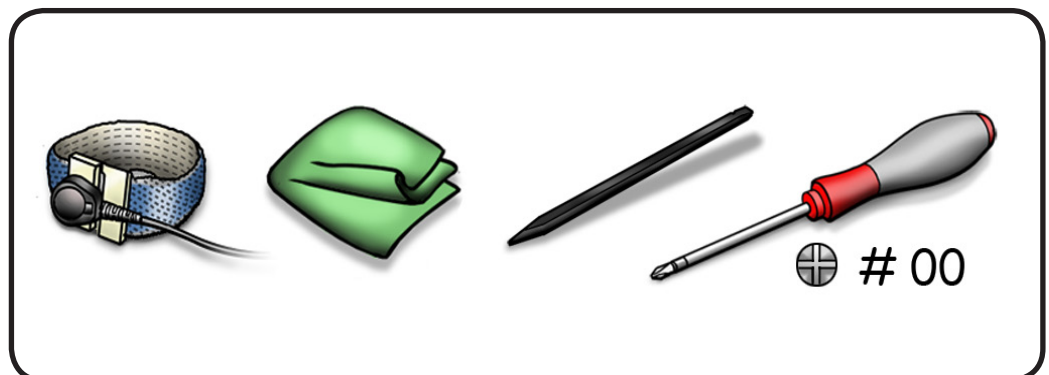



Removal

- 1 Disconnect the speaker cable from logic board.

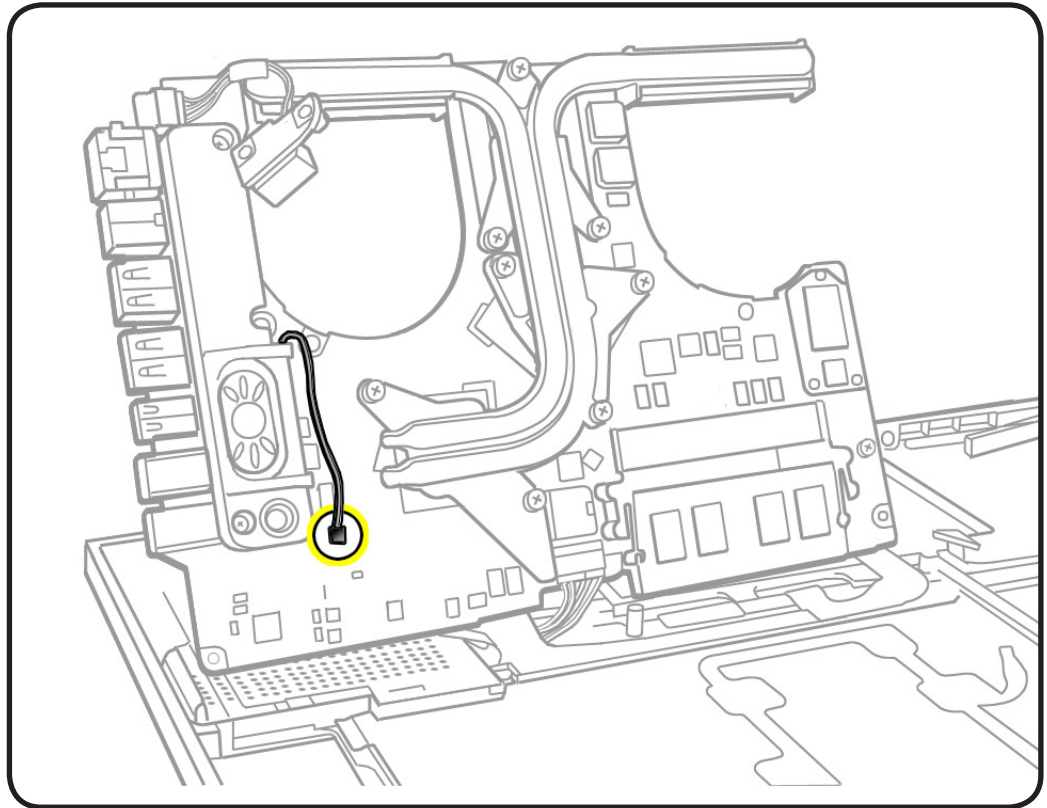

- 2 Disconnect microphone cable from the connector on top side of logic board.

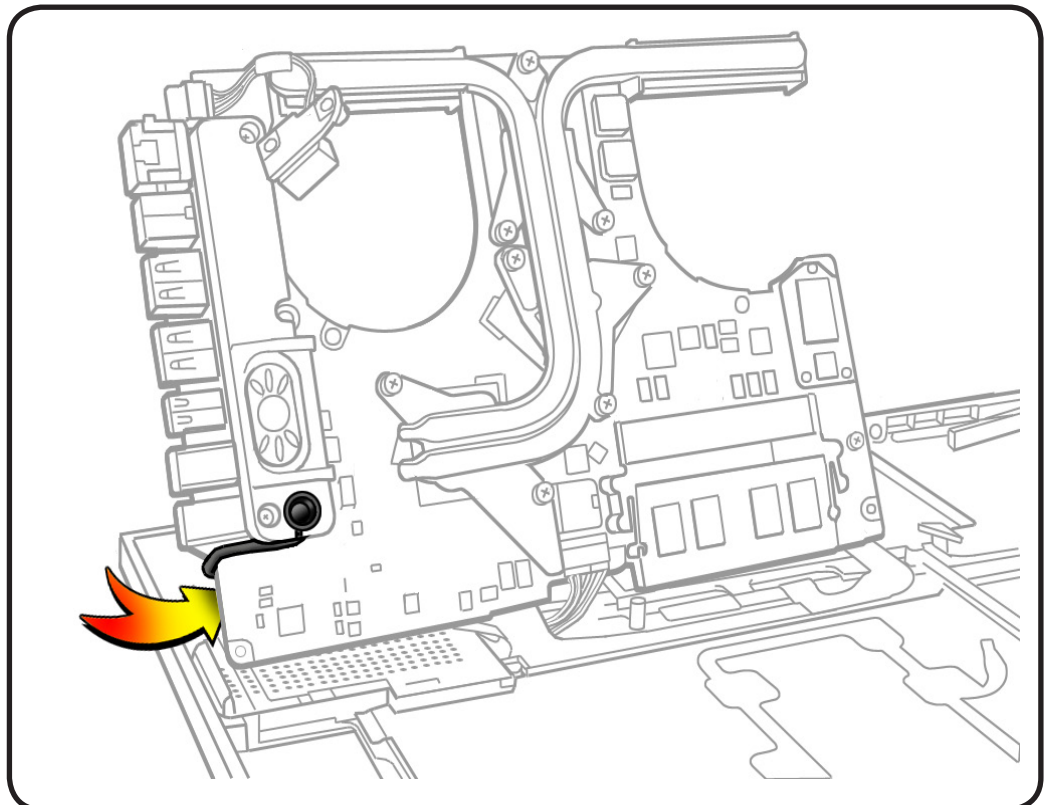



- 3** Remove 2 (5-mm) screws 922-8744.
Note: Do not touch the soft speaker cone.

Replacement Note: If replacing the speaker, transfer microphone to replacement speaker.

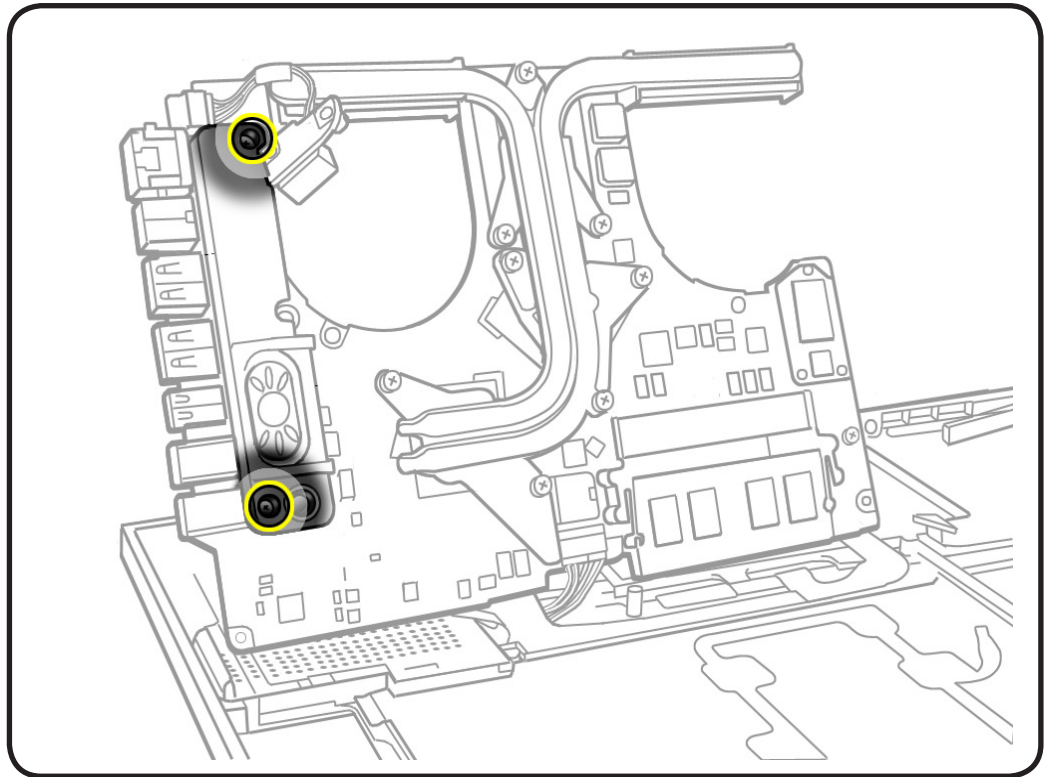



Microphone

First Steps

Remove:

- [Access door](#)
- [Battery](#)
- [Bottom case](#)
- [Fans](#)
- [LVDS cable guide](#)
- [Memory](#)
- [Logic board](#)

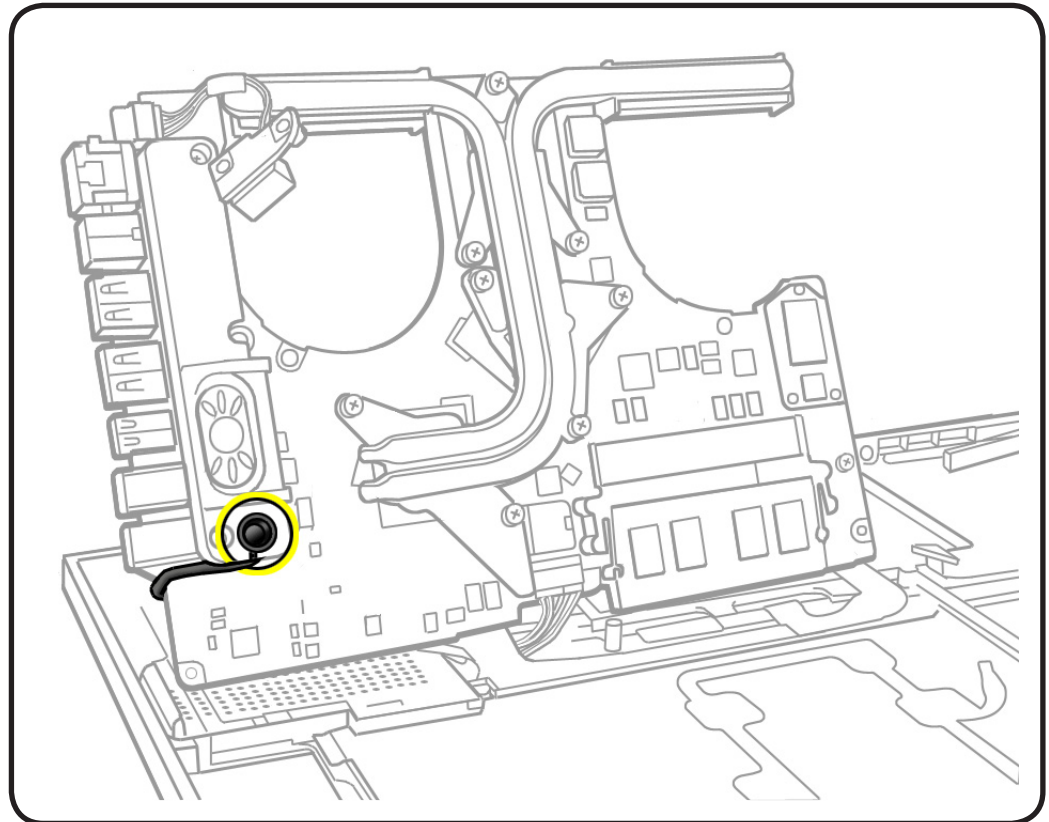

Tools

- Clean, soft, lint-free cloth
- ESD wrist strap and mat
- Magnetized Phillips #00 jeweler's screwdriver?
- Black stick

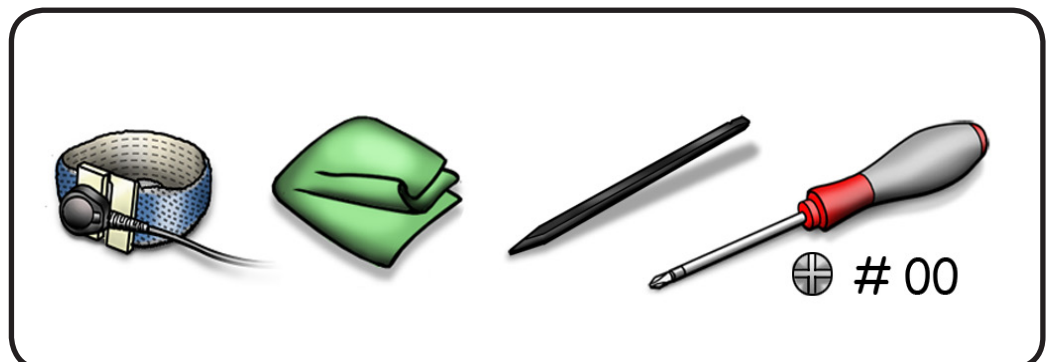



Removal

- 1** Disconnect microphone cable from top side of logic board.
- 2** Use black stick to pry microphone cable from groove on speaker assembly.

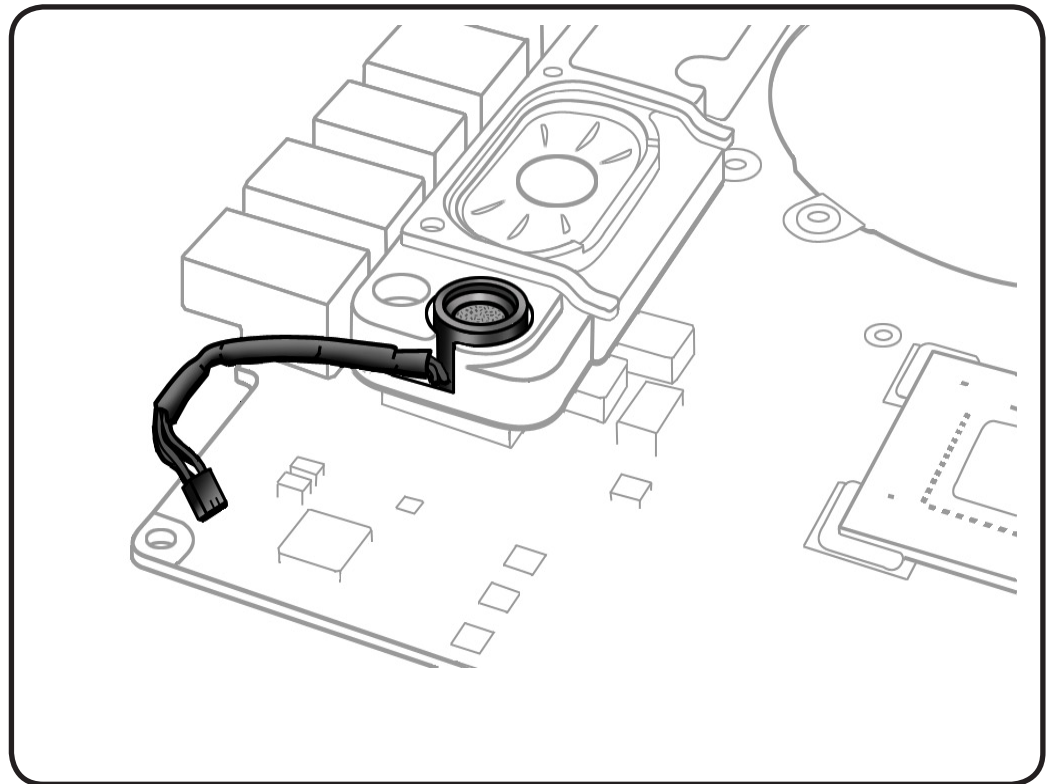



MagSafe Board

First Steps

Remove:

- [Access door](#)
- [Battery](#)
- [Bottom case](#)
- [Fans](#)
- [LVDS cable guide](#)
- [Logic board](#)

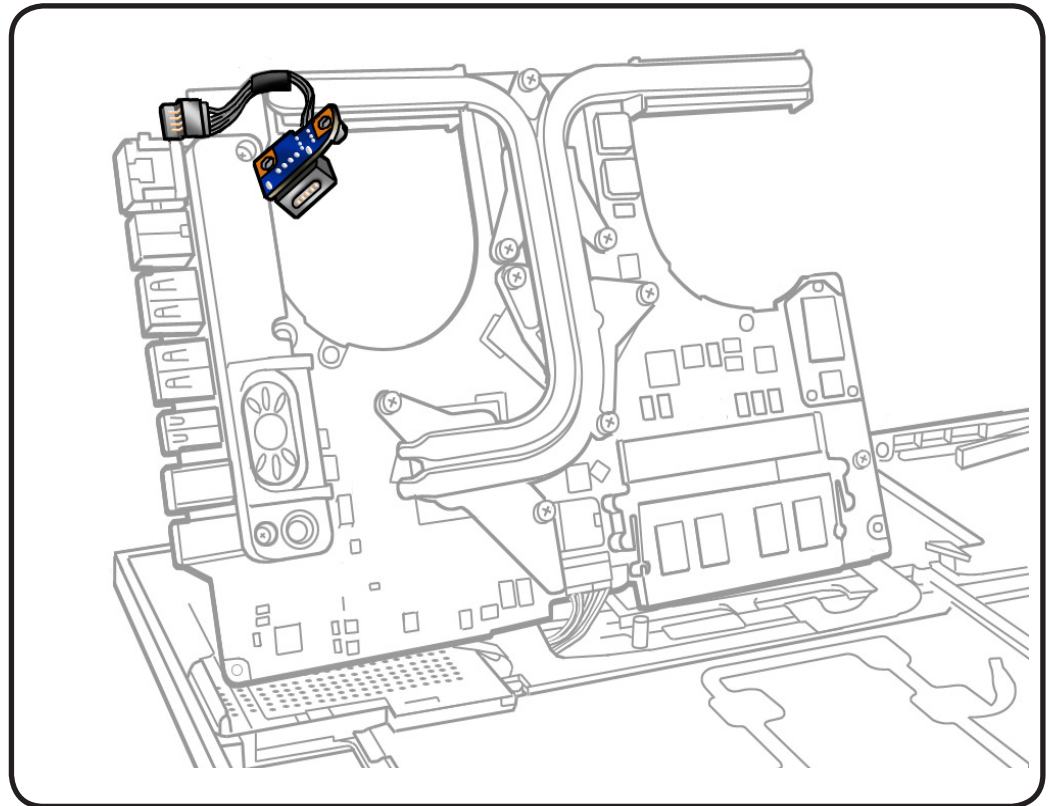

Tools

- Clean, soft, lint-free cloth
- ESD wrist strap and mat

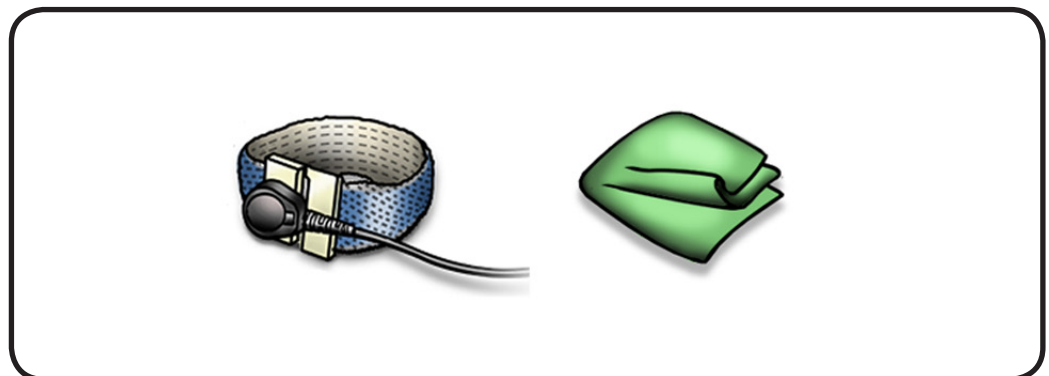



Removal

- 1 Disconnect MagSafe cable from underside of logic board

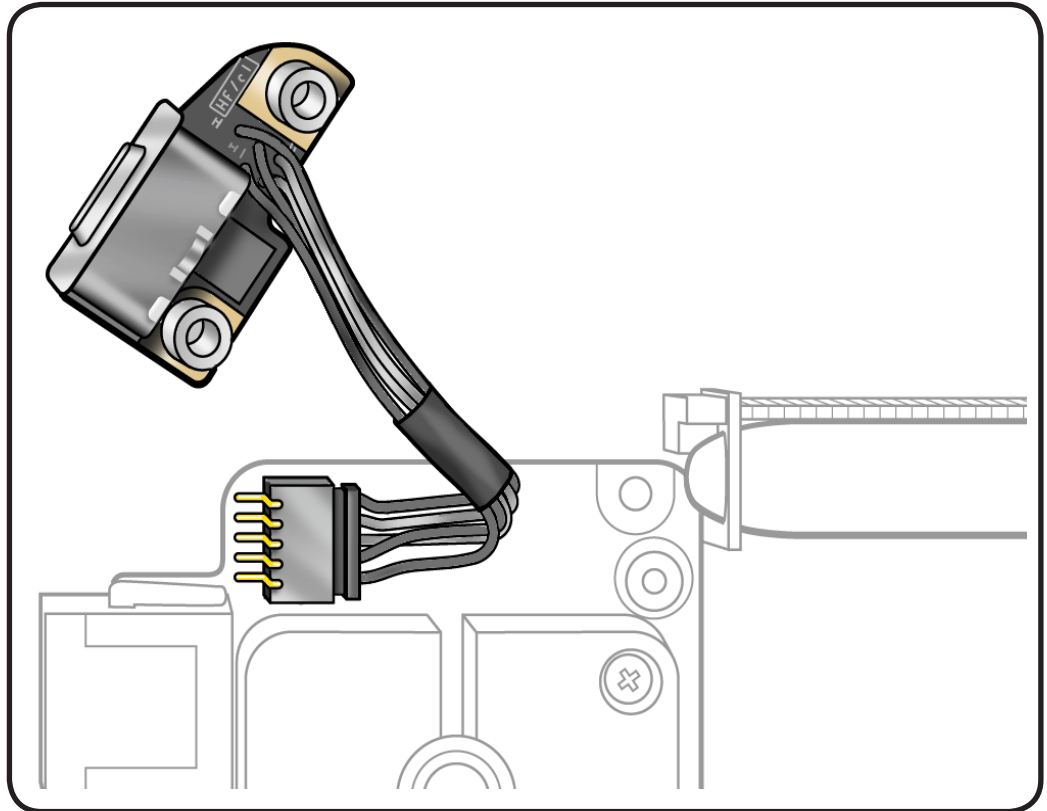

Replacement Note: After installing the MagSafe screws, check the port connection by plugging in a disconnected power adapter cable. If the MagSafe port is off center, the cable will not plug in securely, and you must reinstall the MagSafe board.

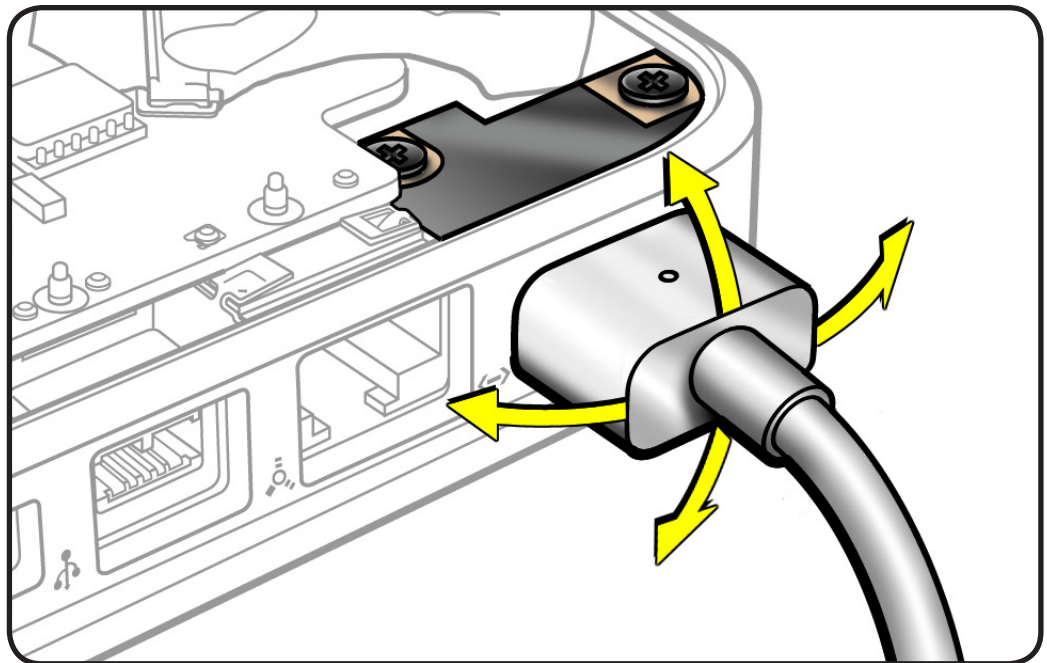



Center Bracket

First Steps

Remove:

- [Access door](#)
- [Battery](#)
- [Bottom case](#)
- [Fans](#)
- [LVDS cable guide](#)
- [Logic board](#)

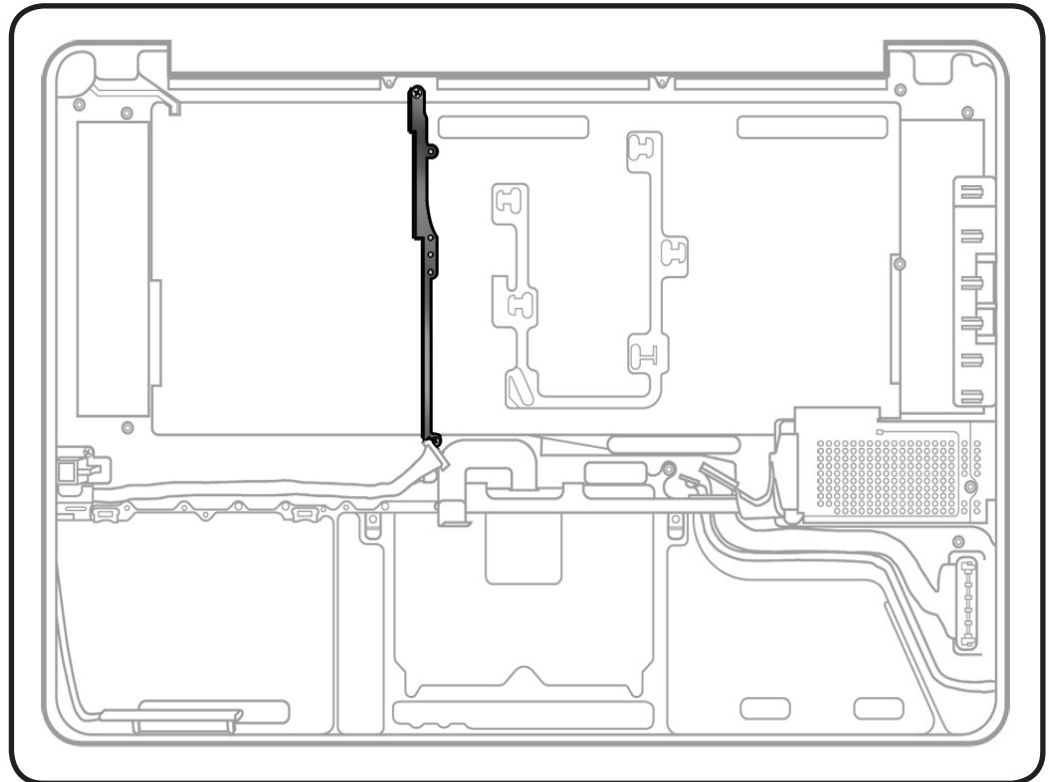

Tools

- Clean, soft, lint-free cloth
- ESD wrist strap and mat
- Magnetized Phillips #00 screwdriver

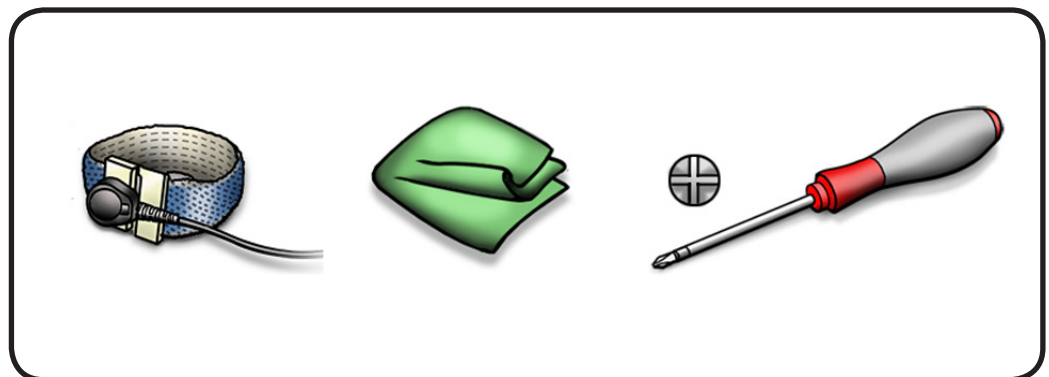



Removal

- 1 Remove 2 screws:
 - 10-mm (922-8648)
 - 6.2-mm (922-8725)
- 2 Remove center bracket.

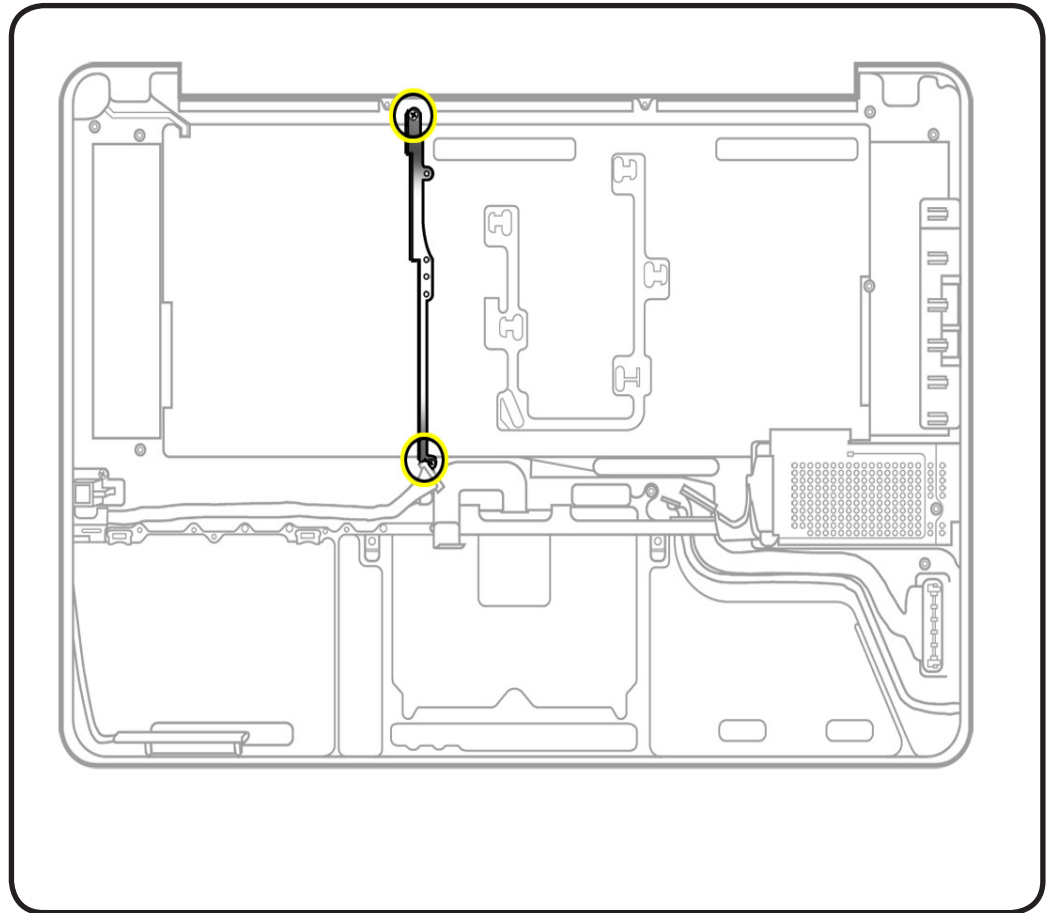



Cable Clip for AirPort Card

Refer to [AirPort Card](#)

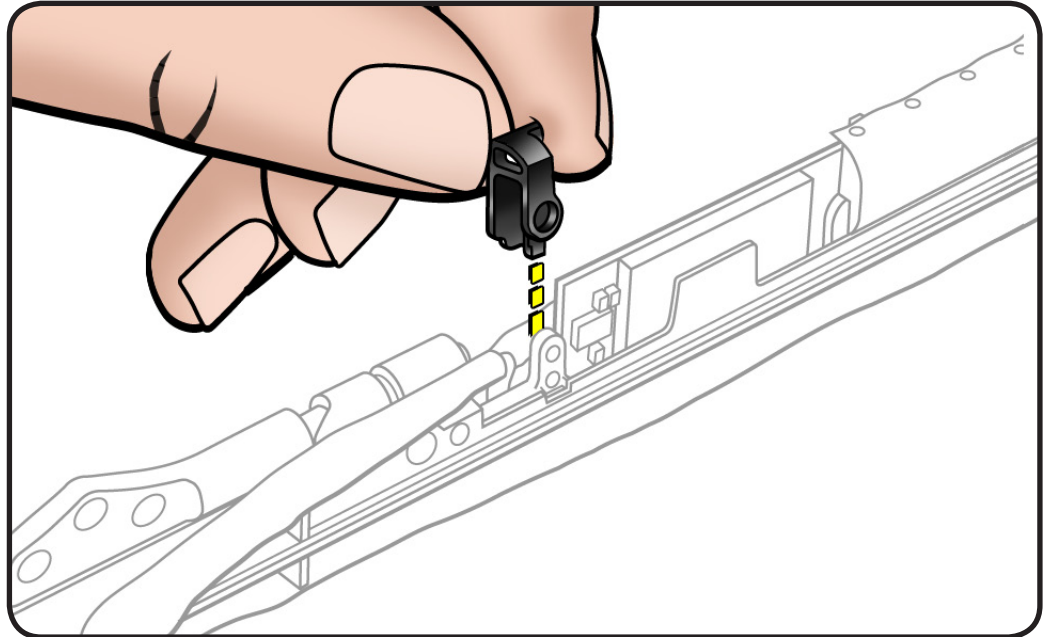



HD Front Bracket/Flex Cable with IR and Sleep LED

First Steps

Remove:

- [Access door](#)
- [Battery](#)
- [Hard drive](#)
- [Optical drive](#)
- [Right speaker](#)
- [Midwall](#)



This cable has a very narrow neck at its connection point to the main logic board. Handle with care or it could tear.

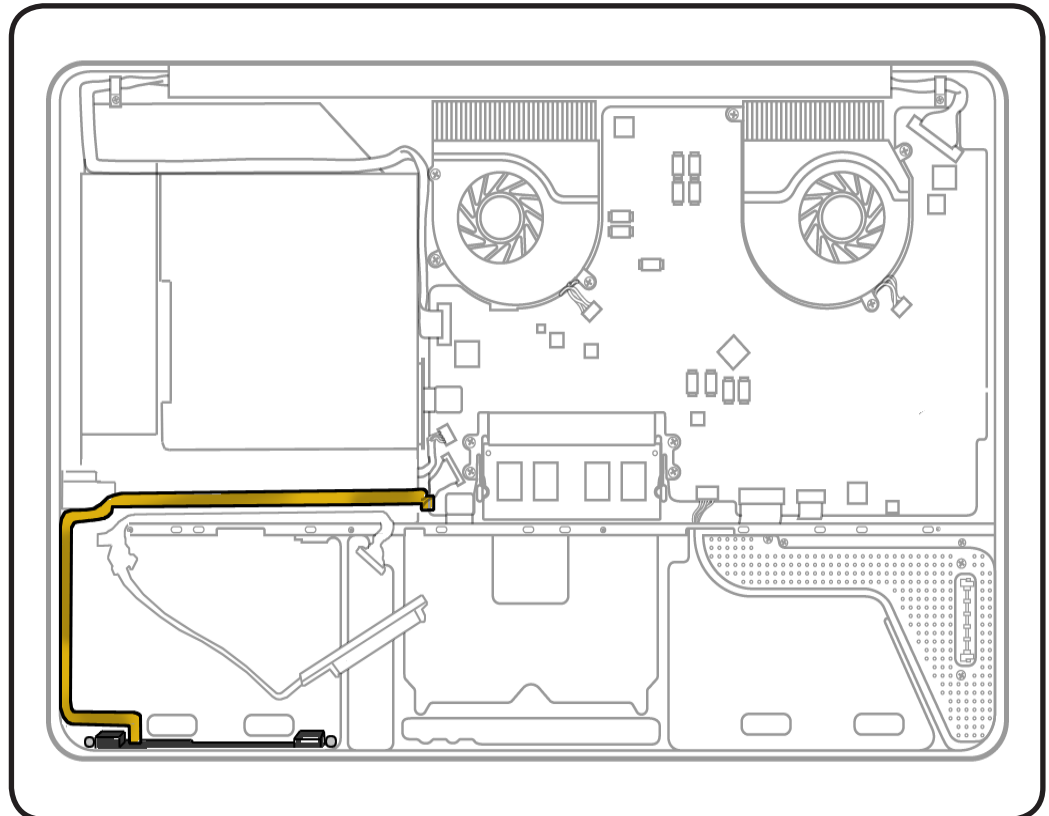

Tools

- Clean, soft, lint-free cloth
- ESD wrist strap
- Black stick
- Magnetized Phillips #00 screwdriver
- Tweezer

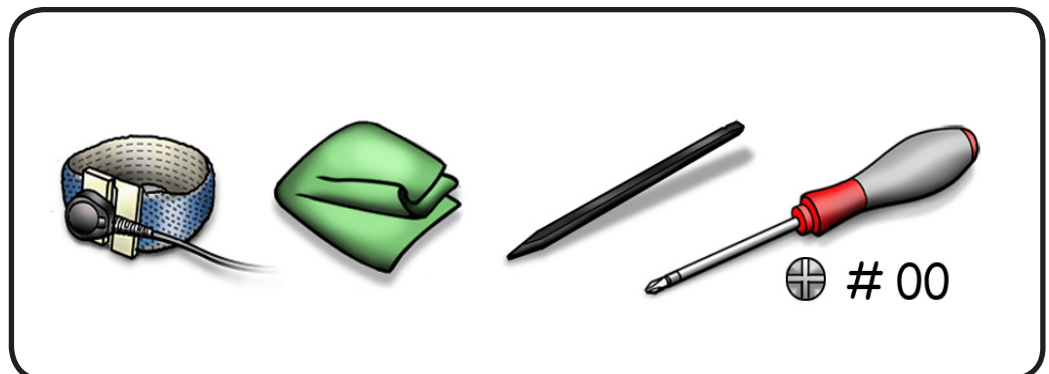



Removal

- 1 IMPORTANT:**
Disconnect the trackpad flex cable before disconnecting the adjacent front IR/Sleep indicator flex cable.

Removing the trackpad flex cable first reduces the likelihood of damaging the front IR/Sleep indicator flex cable.

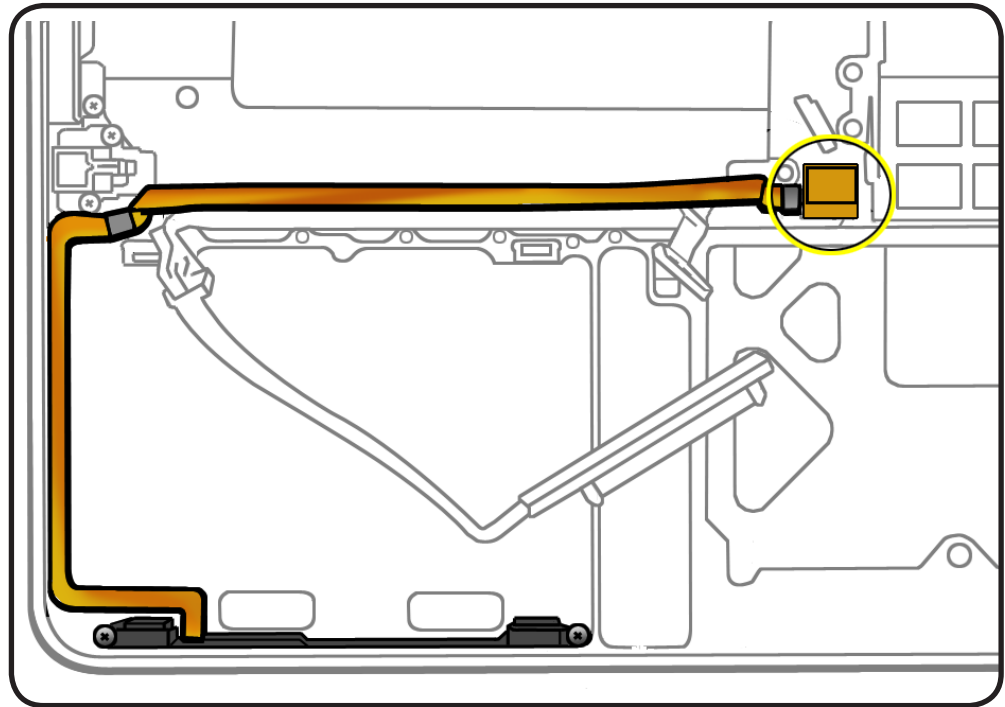

- 2** Remove 2 (3.3-mm) 922-7620 screws attaching front bracket to top case.

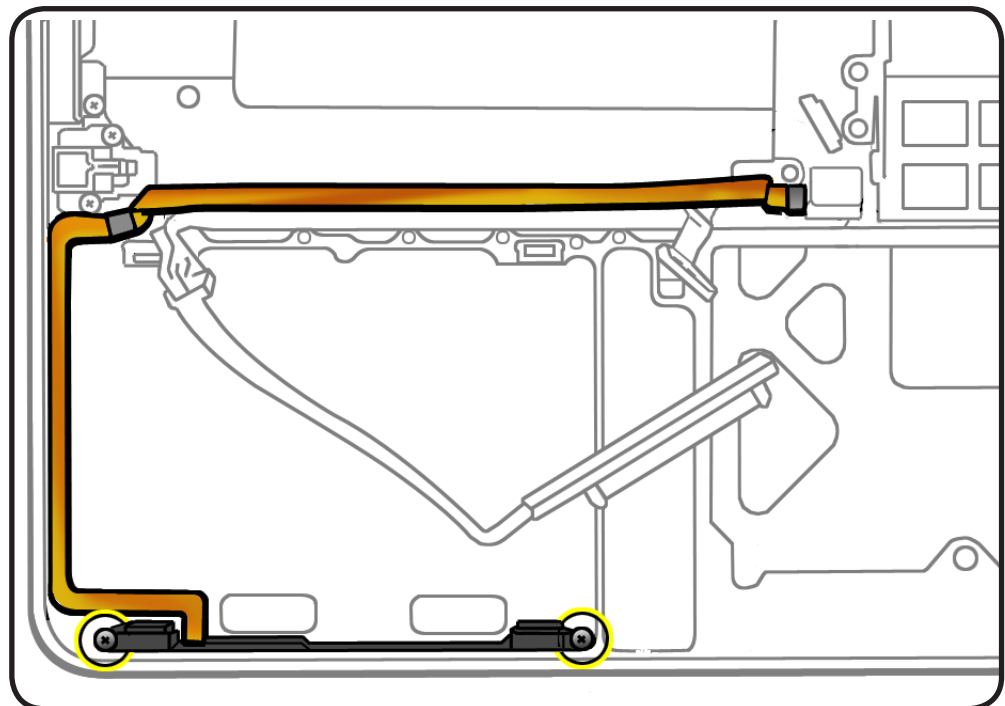



- 3 CAUTION:** With a fingernail or black stick, carefully flip the IR/Sleep indicator locking lever connector to the “open” position.

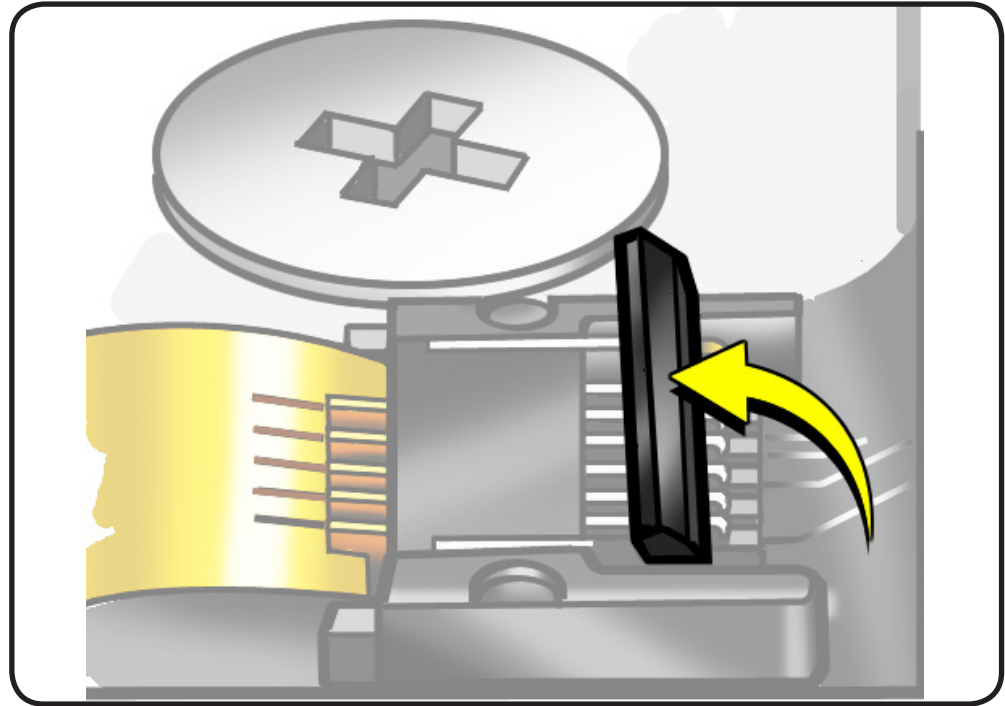

- 4** Without straining the cable, pull it straight out of the connector.

Important: Flip the locking lever to the closed position (down) after removing the flex cable to protect the connector. See graphic on next page.

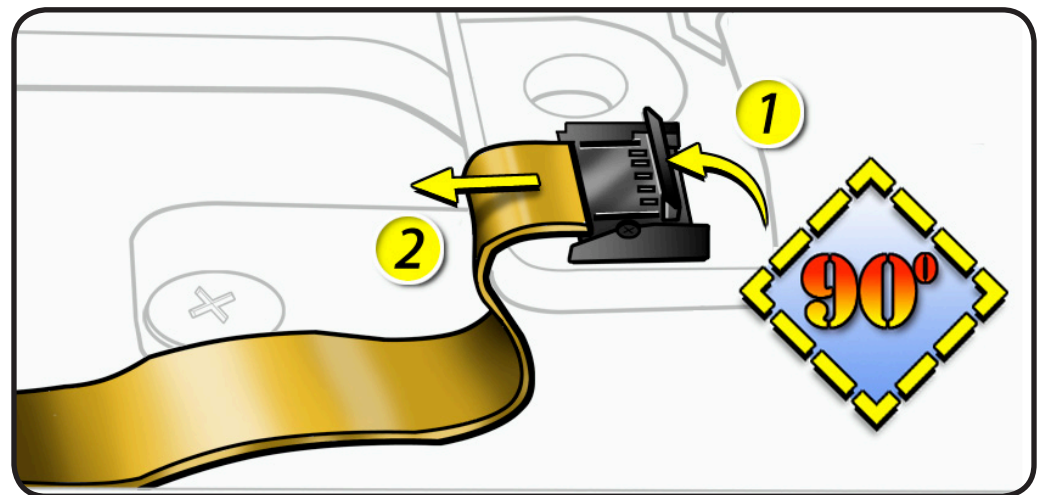

- 5** Lift the entire IR/Sleep indicator cable and front bracket from the top case.



Reassembly

1. If installing a new cable, peel off adhesive backing from cable, press cable onto top case and carefully insert the cable into the connector. Lock down the lever.
2. **For known bad boards (KBB):** Close all locking lever connectors on the logic board when returning the board to Apple. Connectors left in the “open” or up position during shipment can break, causing damage to the logic board.

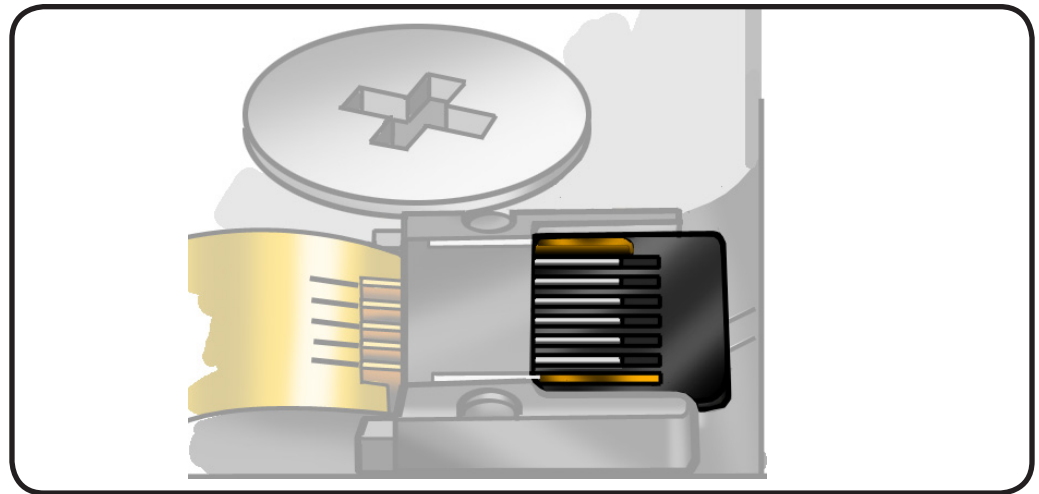

Troubleshooting Tip:

If the system is having trouble going or staying asleep, check the flex cable. Try reseating the cable in the connector.



Express Card Cage

First Steps

Remove:

- [Access door](#)
- [Battery](#)
- [Bottom case](#)
- [Fans](#)
- [LVDS cable guide](#)
- [Logic board](#)

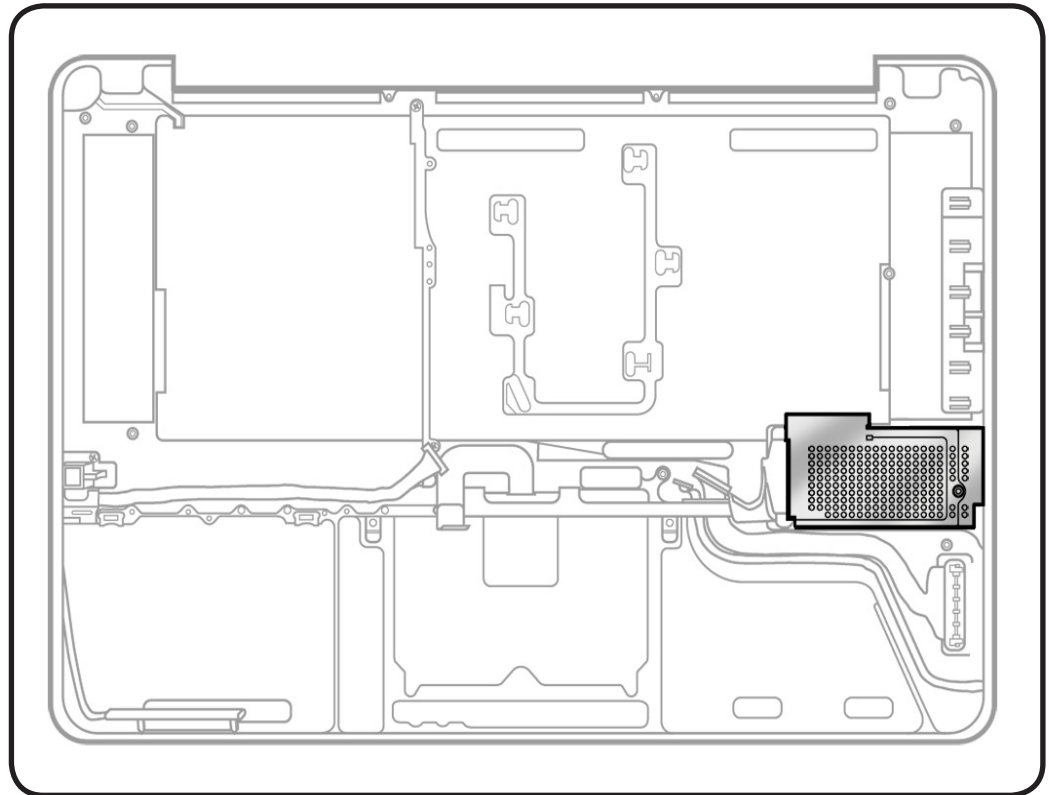

Tools

- Clean, soft, lint-free cloth
- ESD wrist strap
- Magnetized Phillips #00 screwdriver.

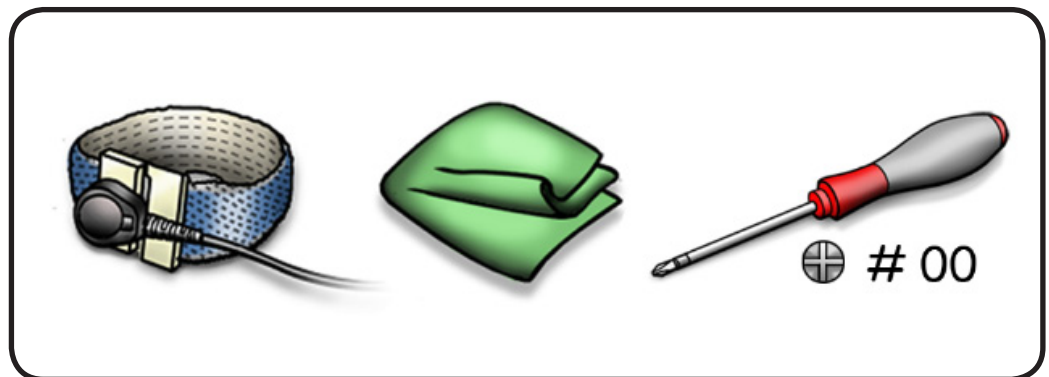



Removal

- 1 Remove 4 black screws:
 - 2 (4-mm) 922-8722
 - 2 (1.85-mm) 922-8723
- 2 Lift card cage from the top case.

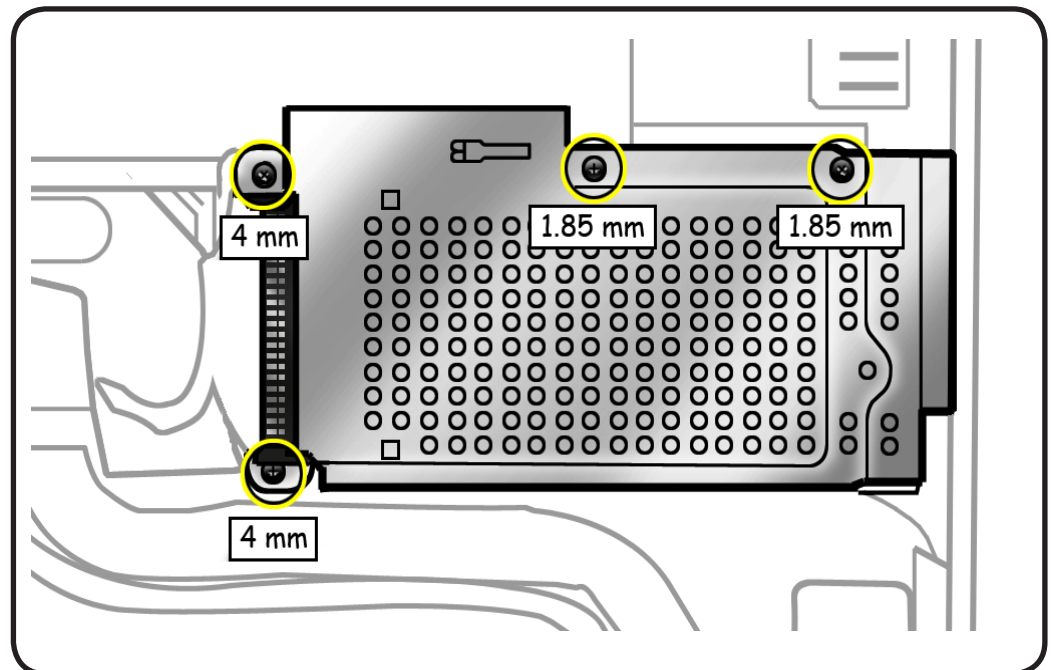



Kensington Lock

First Steps

Remove:

- [Access door](#)
- [Battery](#)
- [Bottom case](#)

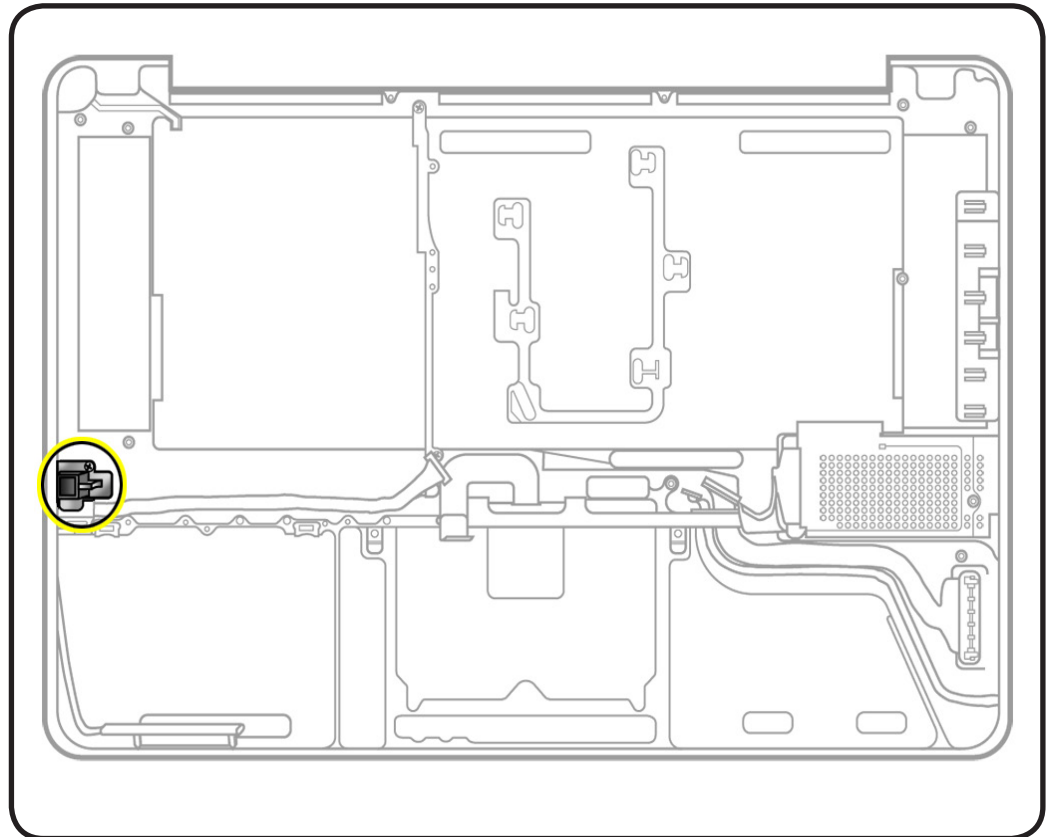

Tools

- Clean, soft, lint-free cloth
- ESD wrist strap and mat
- Magnetized Phillips #00 screwdriver

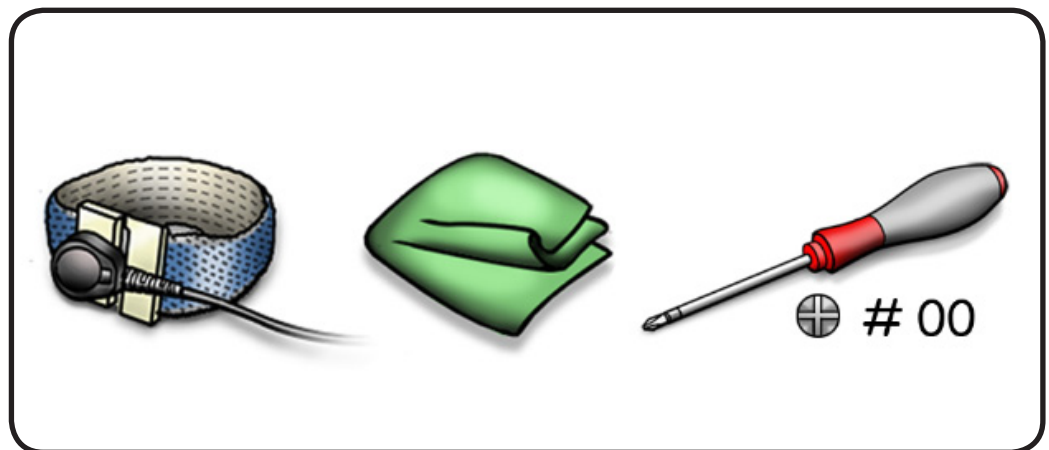



Removal

1 Remove 2 (4 mm) screw (screw part number not offered).

2 Lift out lock.

Note that the lock includes the plastic piece and metal shield.

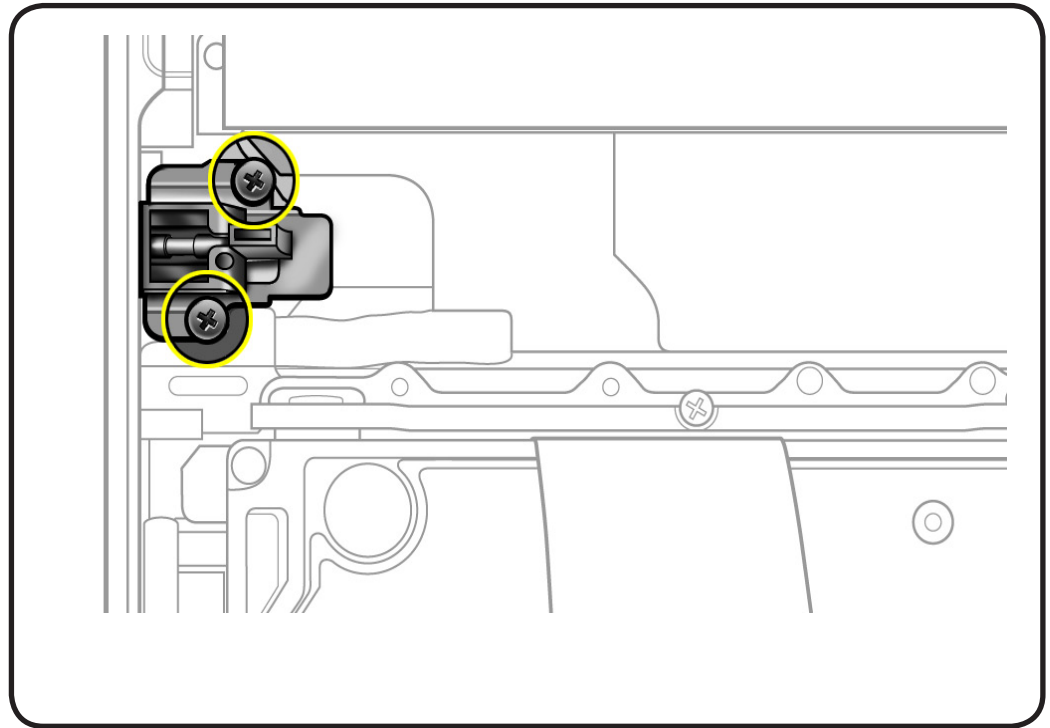



Top Case

First Steps

Remove:

- [Access door](#)
- [Battery](#)
- [Bottom case](#)
- [Optical drive](#)
- [Hard drive](#)
- [Fans](#)
- [Midwall](#)
- [Battery connector cover](#)
- [Camera cable guide](#)
- [LVDS cable guide](#)
- [Logic board](#)
- [Display assembly](#)
- [Right speaker](#)
- [Express card cage](#)
- [Center bracket](#)

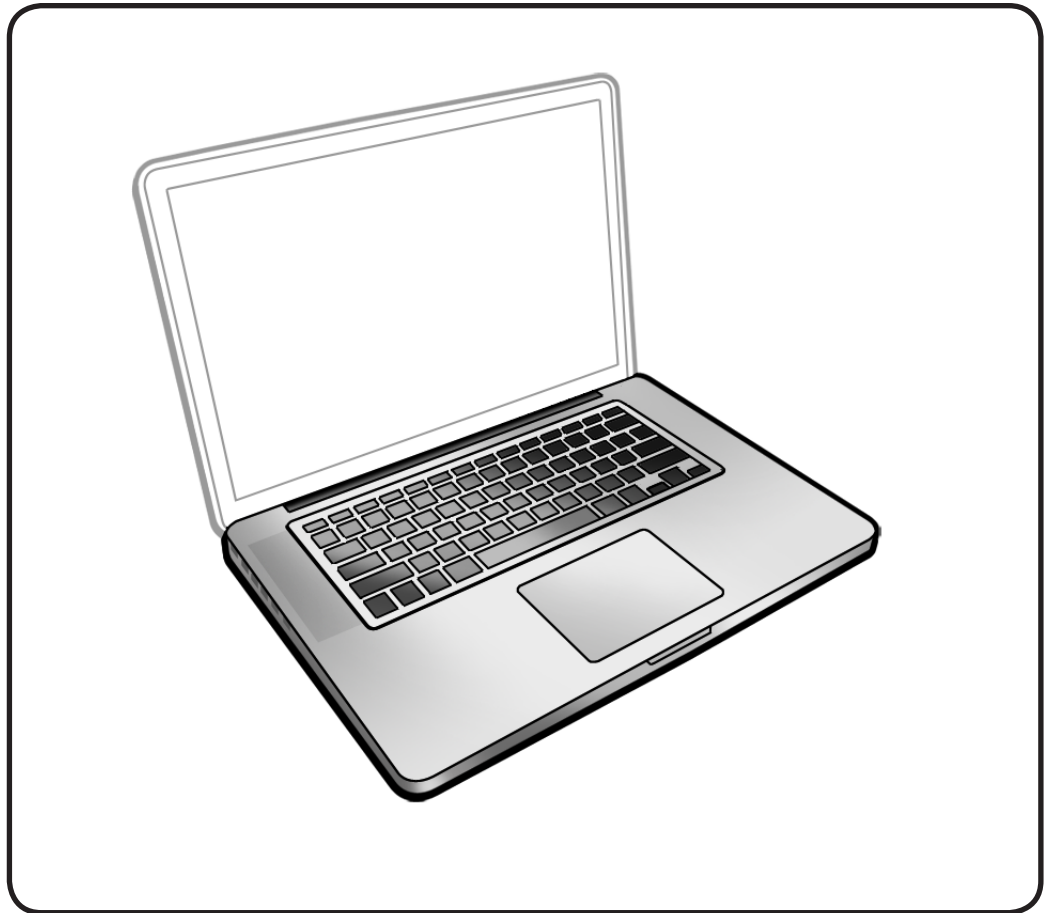

Tools

- Clean, soft, lint-free cloth
- ESD wrist strap
- Magnetized Phillips #00 screwdriver.

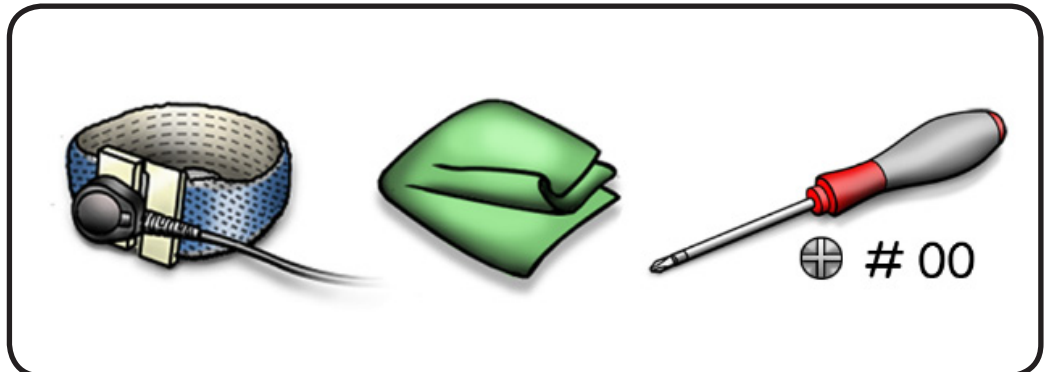



Removal

With the first steps completed, the top case with keyboard is the remaining part.

The top case includes:

- battery indicator light board and cable
- battery cable connector cover
- hard drive cable
- front bracket IR/sleep indicator cable
- Kensington lock

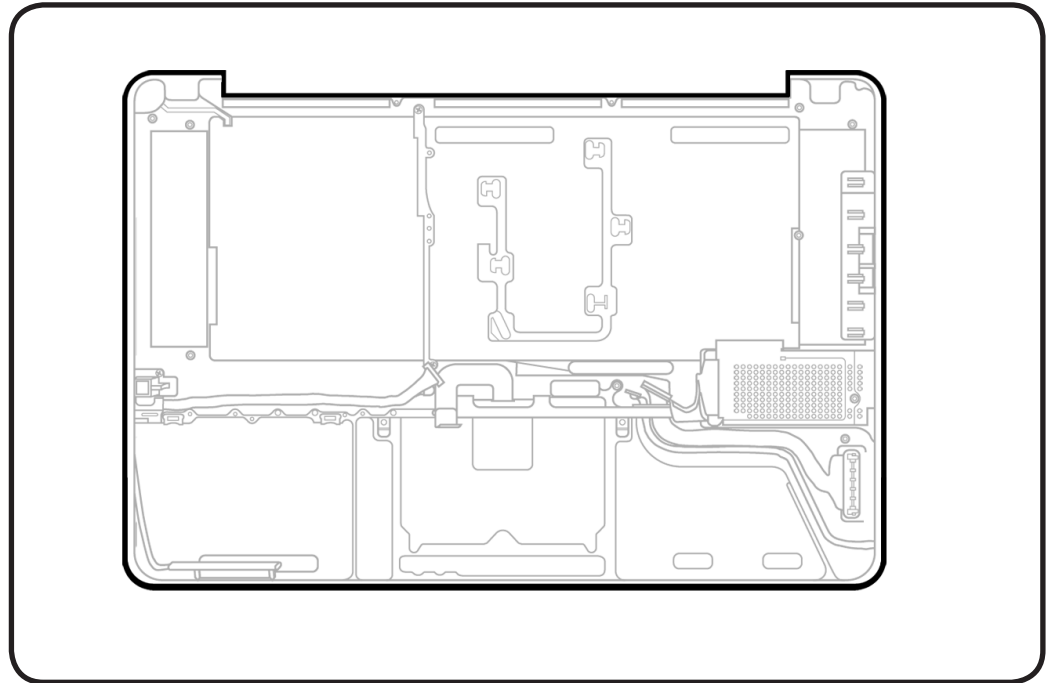

Replacement

1 Before assembling the computer, be sure to first transfer the following 3 parts to the new top case:

- center bracket
- express card cage
- midwall

2 Transfer the serial number to inside edge of top case (see arrow for location). Remove the original serial number label with a jeweler's flat blade screw driver and transfer it to the replacement top case.

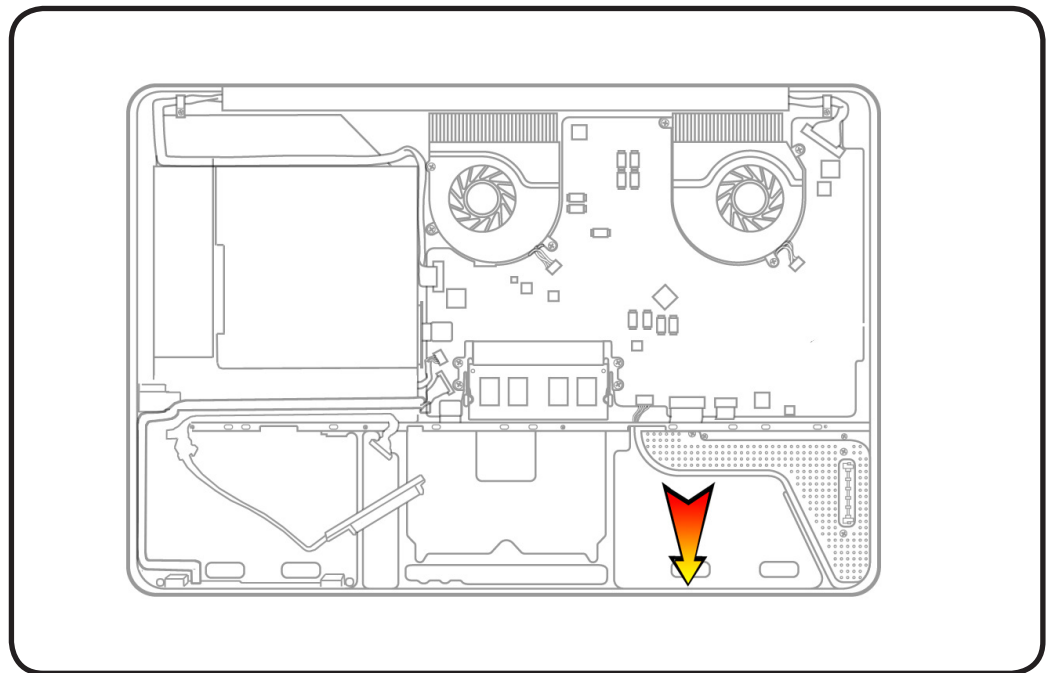



Top Case Information

The top case has been updated. It's important to note that the current and the previous top cases are compatible and interchangeable. Do not SDOA a top case if it's missing the side latch bracket. The latch bracket is no longer necessary

Earlier top cases had a latch holder bracket (circled) to hold the lollipop bracket (922-8716). Current production top cases (661-4948) do not have a latch holder bracket. The latch holder is no longer necessary and the lollipop bracket and two screws do not need to be transferred when replacing a top case.

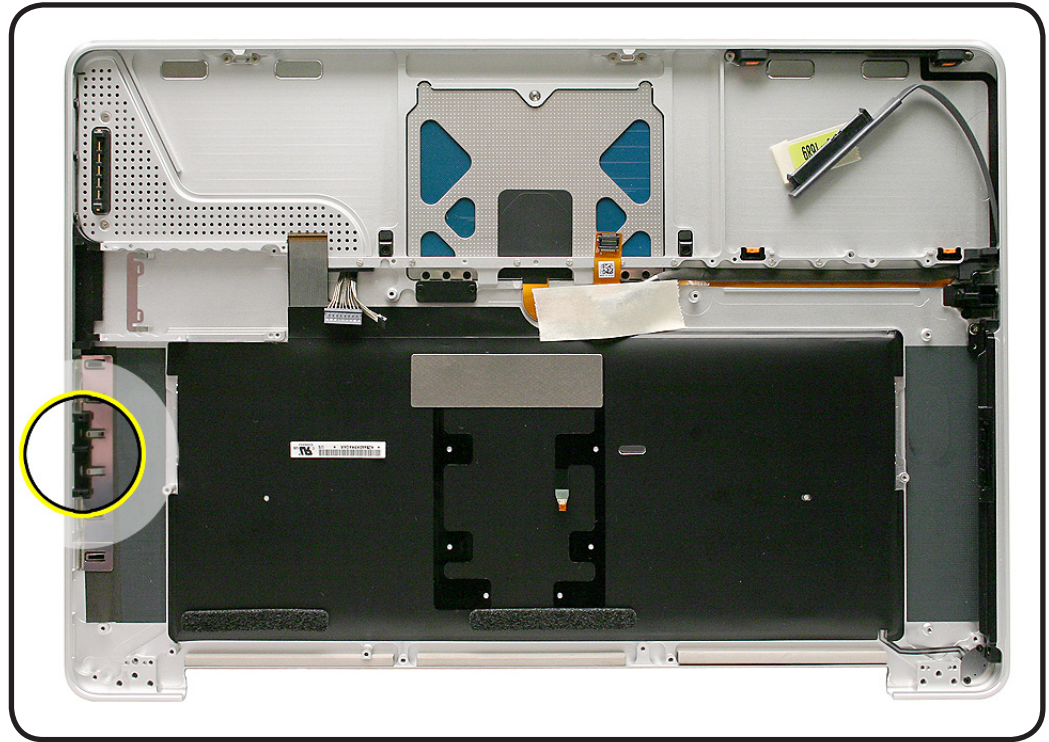

Apple Technician Guide

Views

MacBook Pro (15-inch, Late 2008)



Exploded Views

Main Assembly 1

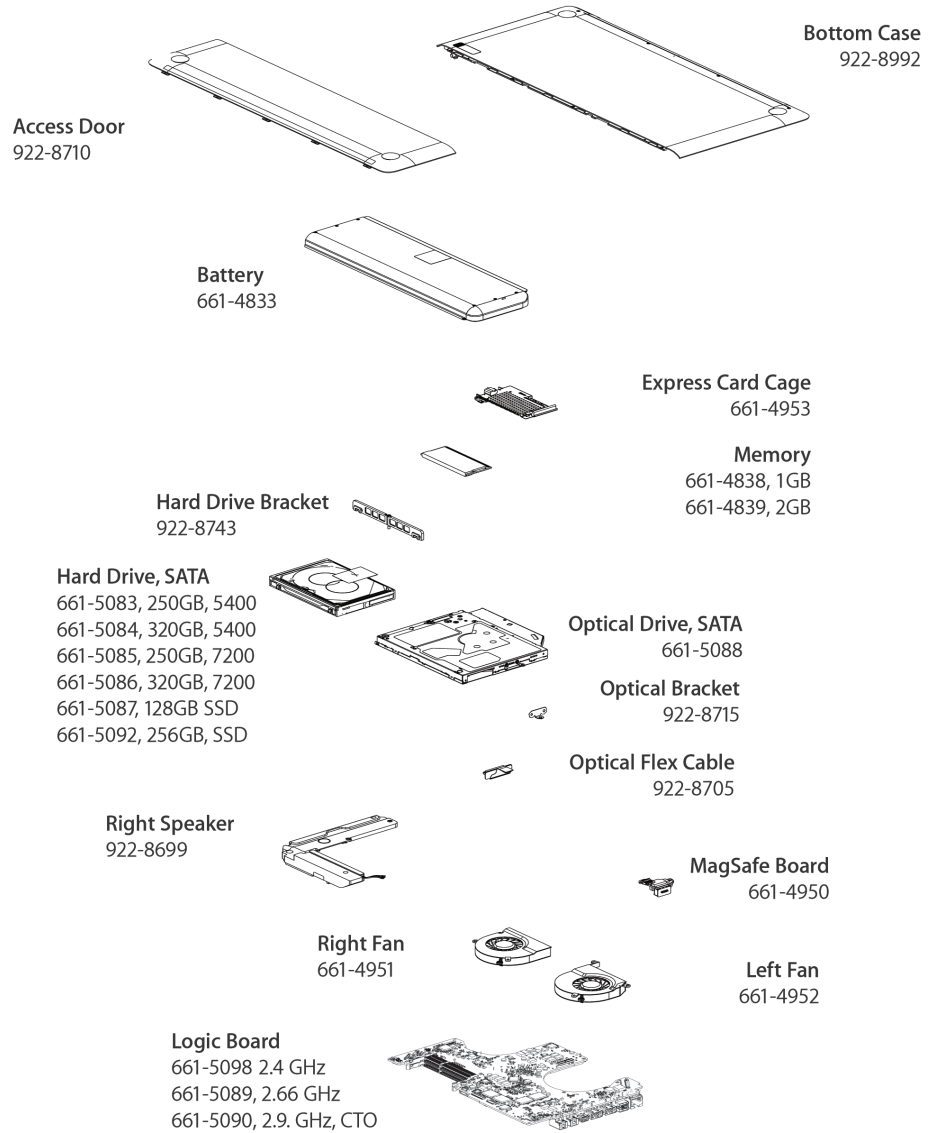



Main Assembly 2

Logic Board
 661-5098, 2.4 GHz
 661-5089, 2.66 GHz
 661-5090, 2.93 GHz, CTO

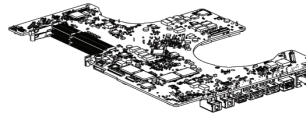

I/O Bracket (Not Shown)
 922-8716

Microphone
 922-8701

Thermal Module
 661-4949

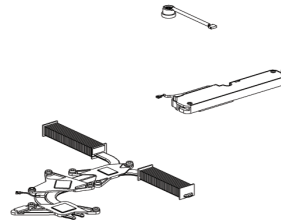

Left Speaker
 922-8700

Midwall
 922-8993



Kensington Lock
 922-8790



Battery Connector Cover
 922-8717

Hard Drive Cable
 922-8706



**Front Hard Drive Bracket
 with IR & Sleep LED**
 922-8788



Battery Power Cable
 922-8708



Battery Indicator Cable
 922-8707



Center Bracket
 922-8712



Button, Battery Indicator
 922-8792

Camera Cable Guide
 922-8714



Battery Indicator Board
 922-8726

LVDS Cable Guide
 922-8713



Not shown:
 922-8938 Cable, Mini DP to Dual-Link DVI
 FE922-8938 Cable, Mini DP to Dual-Link DVI-FAE

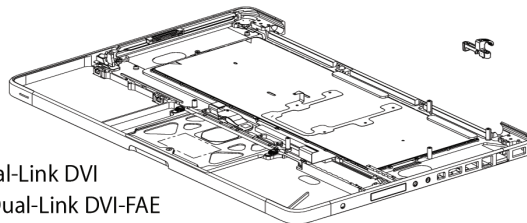

Top Case with Keyboard
 661-4948
TrackPad Kit, 922-9008



Display Assembly

Kit, AirPort Card
(Contains clip (shown)
screws, thermal pad)
076-1327

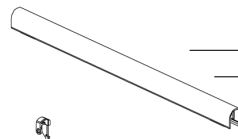

Clutch Cover, Display
922-8789



AirPort Card
661-4766, US
B661-4766, British/Euro
J661-4766, AirMac, Japan
KH661-4766, Korean
PA661-4766, Pacific Rim
Z661-4766, Rest of World



AirPort Antenna
922-8782

**Display Assembly
without AirPort Card**
661-5091, Glossy

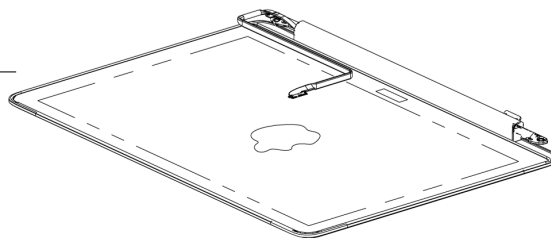



External Views

Front View





Port View

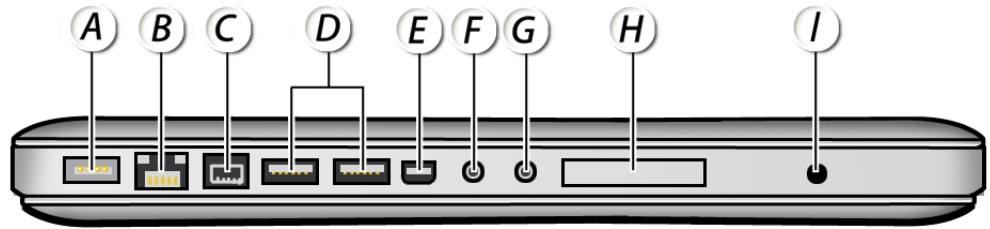

A- MagSafe

B - Gigabit Ethernet

C- FW 800

D- USB 2.0 (1 high powered)

E. Mini DisplayPort

F- Combo Digital/Analog In









G- Combo Digital/Analog Out

H- Express Card Slot











I- Battery Indicator Light Button



Screw Chart

<p>076-1321 Phillips #00</p>  <p>Included in Logic Board Kit:</p>	<p>076-1327 Phillips #00</p>  <p>Included in AirPort Card Kit: antenna (4), card (2), cable clip (1)</p>	<p>922-7620</p>  <p>Hard drive front bracket/IR/ Sleep LED (2)</p>
<p>922-8645 Phillips #00</p>  <p>LVDS cable guide (1), MagSafe board (2)</p>	<p>922-8646 Torx 6</p>  <p>Hinge to top case (6)</p>	<p>922-8648 Phillips #00</p>  <p>Center bracket to top case (1)</p>
<p>922-8653 Phillips #00</p>  <p>Bottom case (4)</p>	<p>922-8656 Phillips #00</p>  <p>Midwall to top case (3)</p>	<p>922-8666 Phillips #00</p>  <p>Bottom case to top (3)</p>
<p>922-8719 Phillips #00</p>  <p>Optical drive plate to ODD bracket (2)</p>	<p>922-8720 Phillips #00</p>  <p>LVDS cable guide (1), camera cable guide (1)</p>	<p>922-8722 Phillips #00</p>  <p>Express cage front (2)</p>



<p>922-8723 Phillips #00</p>  <p>Express cage to top (2)</p>	<p>922-8725 Phillips #00</p>  <p>Center bracket to top case , botom (1)</p>	<p>922-8744 Phillips #00, 5-mm</p>  <p>Left speaker to logic (2), right speaker to top case (1)</p>
<p>922-8745 Phillips #00</p>  <p>Bottom case to camera cable guide</p>	<p>922-8747 Phillips #00</p>  <p>Speaker, center (1)</p>	<p>922-8753 Phillips #00, shoulder</p>  <p>Bracket, snap, I/O port (2), original model only</p>
<p>922-8754 Phillips #00</p>  <p>Logic board (7), Fan , right speaker to top (2)</p>	<p>922-8755 Phillips #00</p>  <p>Battery indicator screw (3)</p>	<p>922-8756 Torx T6</p>  <p>Display assembly hinges (6)</p>
<p>922-8799 Phillips #00</p>  <p>Heatsink and heatsink spring</p>	<p>922-8994</p>	<p>922-8995</p>



Screw Location Diagrams

Bottom Case Screws

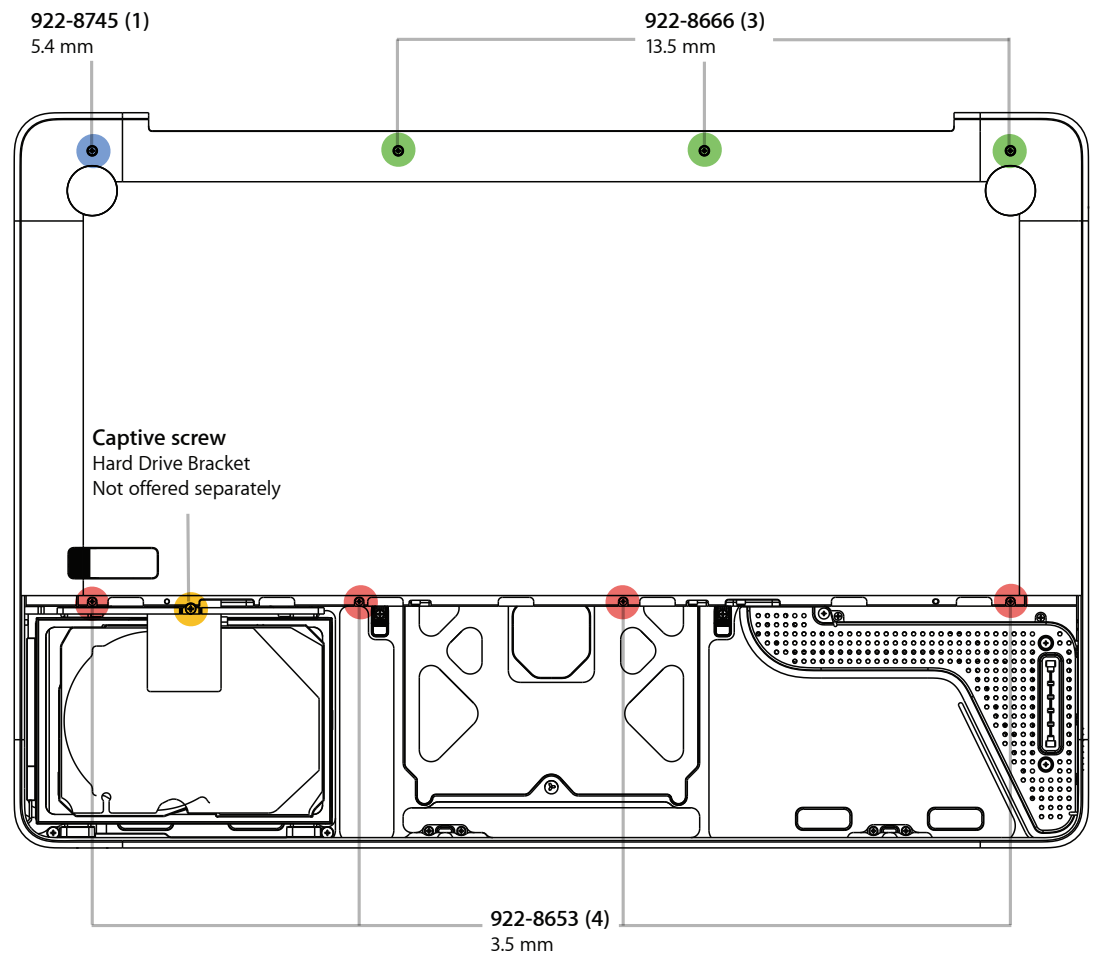



Top Case to Display Assembly Screws

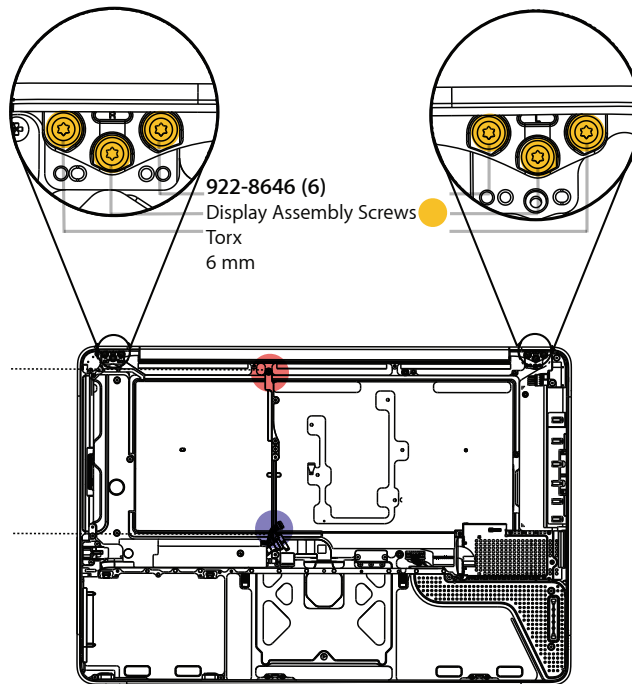
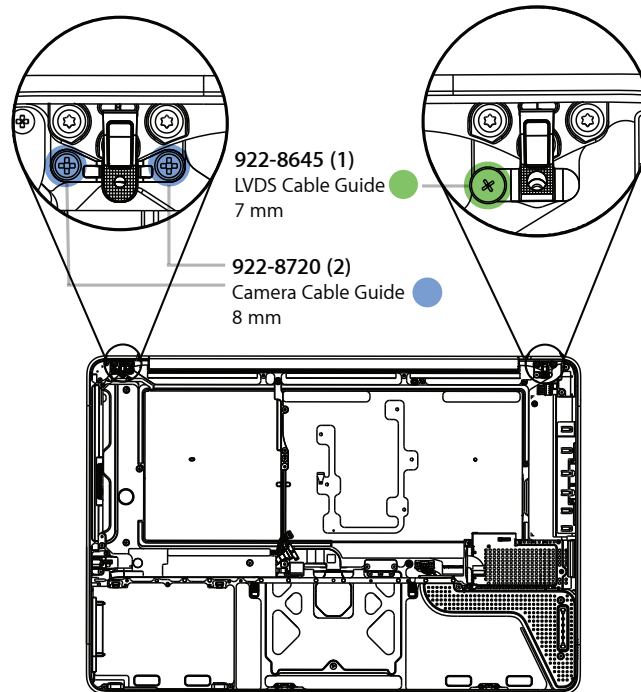



Main Modules to Top Case Screws

